



WESSEX PICTURES



Twelfth Edition

Your one stop shop for all your framing needs



THE PICTURE FRAMING

Trend Setters



Welcome

to the 12th edition of our catalogue

	Specialist Glass	18 - 45
	Specialist Plastic Glazing	46 - 61
	Regular Glass/Plastic Glazing	62 - 69
	Mountboard	70 - 123
	Board Products	124 - 133
	Hardware & Adhesive Tapes	134 - 165
	Tools & Equipment	166 - 231
	Dry Mounting	232 - 245
	Display Products	246 - 255
	Miscellaneous	256 - 275
	Costing & Pricing	276 - 281
	Index & Terms of Trading	282 - 287

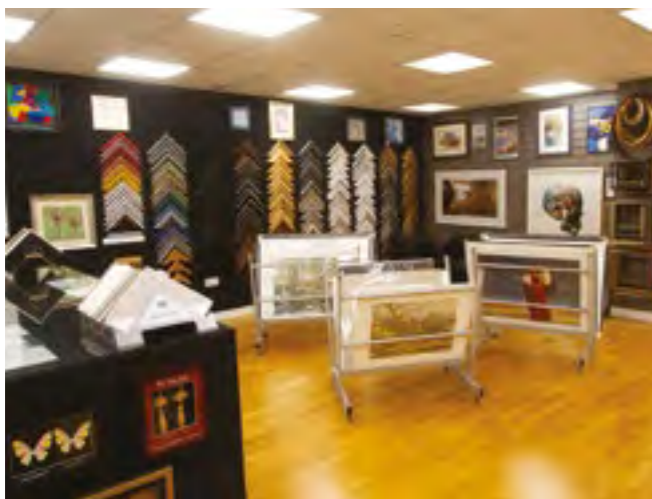

The UK's number 1 regional wholesaler

We have been supplying the picture framing industry for over 40 years and we attribute our success to:

Service

With six branches situated across the UK we can give you **the complete one stop shopping service.**

All our branches offer showrooms where you can be assured of a warm welcome while browsing through our comprehensive range of products. Our friendly staff are always on hand to give help and advice.

Reliability

Our own fleet of vans and friendly drivers are ready to delivery your goods.

Stock

Over 4,500 products covering all aspects of picture framing waiting to be delivered to you.



Delivering in every sense of the word

We operate a fleet of over twenty five commercial vehicles which will deliver your goods anywhere from the south coast all the way to Dundee.

Orders can be placed by phone, e-mail or via our website or we can call you on our weekly 'phone a route' service.

Orders will then be delivered by our friendly team of drivers who will go that little bit further when delivering the goods to your premises.

If any special orders are required that fall out of sync with our usual routes we can still deliver by using a national carrier.

Wessex branches:

Bournemouth Head Office - 01590 681681

Open Mon - Fri 08.30 - 17.00

Ashford - 01233 637104

Open Mon - Fri 08.30 - 17.00

Leamington - 01926 421984

Open Mon - Fri 08.30 - 17.00

Dereham - 01362 690002

Open Mon - Fri 08.30 - 17.00

London - 01372 377738

Open Mon - Fri 08.30 - 17.00

Oldham - 01616 812959

Open Mon - Fri 08.00 - 17.00



Where quality matters

info@wessexfineart.com
01590 681683
 www.wessexpictures.com

Wessex Fine Art has over 40 years' experience in professional bespoke framing for the trade.

Our ever-expanding department caters for every type of customer, from those who out source all their framing needs to one-off specialist jobs.

Our experienced staff are on hand to offer invaluable help and advise on all aspects of framing. If you have a job too big or awkward for you to handle, just give us a call. We can collect, finish the picture and return it in our own vehicles, on your normal delivery route. So, you can be confident any framing passed to us is of the highest quality and standard.

What we can do:

- Dry mounting and heat sealing
- Jumbo mount cutting
- Oval and circle mounts
- Multi aperture mounts
- Framing and routing
- Sports shirts and memorabilia
- Specialist glass cutting
- Oversize framing
- Conservation and museum framing
- Tapestry and embroidery framing
- Aluminium chop service
- Canvas stretching
- Deep box framing

“ I've been able to increase my turnover because of Wessex Fine Art. I've been able to take in jobs I'd otherwise be unable to do due to space and time.

London Framer

“ The knowledgeable, friendly and always helpful staff at Wessex offer outstanding service, quality and reliability. Solidly sticking to FATG standards, giving me the reassurance that the job is done properly inside and out.

Somerset Framer

Our framing services

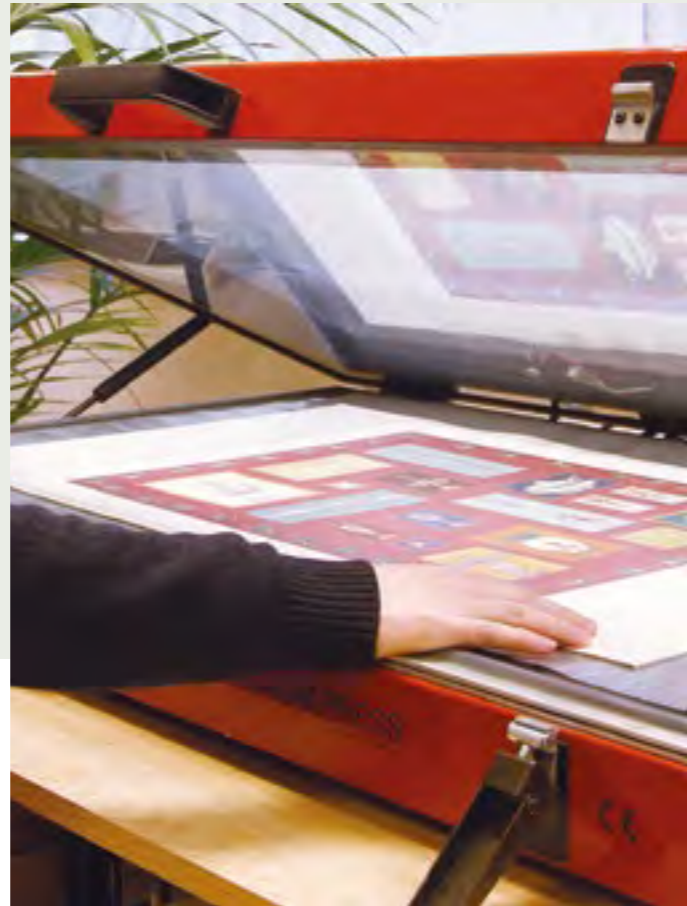

Chop service

Wessex Fine Art will cut the required moulding lengths ready for self-assembly back at your workshop. We also offer a routing service.

Mount service

Save time and wastage with our bespoke service. Get any shape, size and colour with the reassurance of a quality finish, every time.

Our new jumbo mount cutting service can cut mounts up to 2440 x 1220mm.



Full service

Wessex Fine Art will provide the full package - delivering your artwork complete and ready for the customer, taking the hassle out of the framing process for you.

Component service

We provide the components needed to complete the framing process, from one or all of the following: rim, glass, pre-cut mounts, backing board and artwork preparing (dry mount or fabric stretching).



Where no job
is too big or
too small



Chop service

Wessex Fine Art offers a full chop service on aluminium frames and the Wessex range of wooden mouldings, including a routing service for hardwood mouldings if required.

Simply order online using the form and follow the links to Wessex Fine Art at wessexpictures.com



Aluminium mouldings style key:

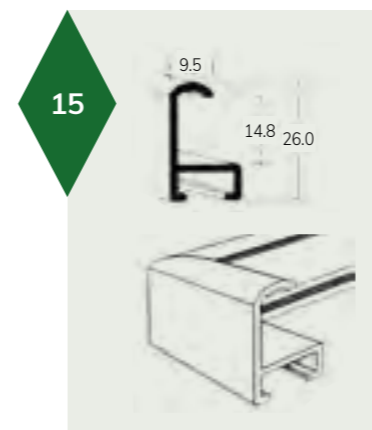
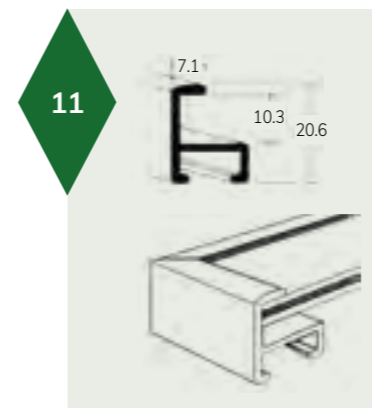
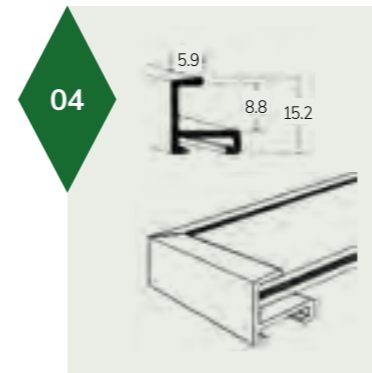

Polished	Available style	Painted	Available style
	01 Polished Gold 04 / 11 / 15		21 Black (Matt) 04 / 11 / 15
	03 Polished Silver 04 / 11 / 15		22 Brown 11
	06 Contrast Grey 04 / 11 / 15		33 Red 04
	16 Jet (Polished Black) 04 / 11 / 15		40 Navy 11
	18 Walnut 11 / 15		56 Glossy White 04 / 11 / 15
	02 Frosted Gold 04 / 11 / 15		69 Cherry Red 15
	04 Frosted Silver 04 / 11 / 15		70 Midnight Blue 15
	08 Coppermatt 11 / 15		82 Capri 15
	10 Mist 11 / 15		98 Ferrari 15
	11 Champagne 04 / 11 / 15		101 Hawaii 04 / 15
	13 Frosted Sterling Blush 15		106 Blueberry 15
	19 Platin 04 / 11 / 15		118 Sunflower 15
	306 Soft Grey 11 / 15		120 Mango 15
	316 Soft Black 11		241 Ceanothus Blue 15
	317 Soft Antique Gold 11 / 15		284 Pearl Silver 15
	318 Soft Walnut 15		285 Pearl Gold 15
	327 Soft Mercury 11 / 15		

Note: colours are for guidance only.

Plastic Glazing

Clear Styrene Diffused Styrene Clear Acrylic Diffused Acrylic UV Cast Acrylic Artshield UV Acrylic TruVue Optium Museum Acrylic

TRU VUE

Float Glass UltraVue UV70 Reflection Control Conservation Reflection Control Museum Glass Conservation Clear

artglass

Float Glass Artglass AR70 Artglass AR92 Artglass AR99WW Artglass UV99

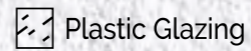

Seven words to more profit

“Which type of glass would you like?”

Give your customers the best choice with our range of specialist glass, and follow these simple steps:

You ask

1. “What moulding would you like?”
2. “What mountboard would you like?”

You should then always ask

3. “Which type of glass would you like?”

Just give us a call and get specialist glass delivered to your door either cut to size, by the sheet or box.

Standard Glass

UV Protective Glass



Protect
your
artwork
against UV damage

Use museum or conservation glazing

Available from Wessex Pictures, the UK's number one specialist glass supplier.

Delivered to your door by our own fleet of vans and can be supplied:

- By the box
- In single sheets
- Cut to size

TRU VUE [®]	UV filtering
UltraVue [®] UV92	92%
UltraVue [®] Laminated	99%
Museum Glass [®]	99%
Conservation Clear [®]	99%
Conservation Reflection Control [®]	99%
Optium Museum Acrylic [®]	99%
Artshield UV	99%

artglass	UV filtering
Artglass AR92 [™]	92%
Artglass AR99WW [™]	99%
Artglass AR99 Protect [™]	99%
Artglass UV99 [™]	99%

Specialist Glass

Tru Vue®



UltraVue UV70®	Virtually invisible glass
UltraVue UV92®	Virtually invisible glass, enhanced UV protection
UltraVue® Laminated	Virtually invisible glass, max UV protection, safety
Conservation Clear®	Maximum UV protection
Museum Glass®	Virtually invisible glass, maximum UV protection
Reflection Control®	Reduction of bad glare
Conservation Reflection Control®	Reduction of bad glare, max UV protection



Standard Glass

UltraVue® UV70



UltraVue® UV70

Tru Vue® Anti-Reflective Coating Technology on Water White Glass

UltraVue® UV70 glass features:

- Anti-reflective - almost invisible
- Amazing clarity
- Enhanced cleanability
- 70% UV filtering
- >98.5% light transmission
- Water white glass
- Less than 1% light reflection

Tru Vue UltraVue® UV70

				Box Qty
GL55	2mm	WaterWhite AR	1220 x 915mm (48" x 36")	2
GL56	2mm	WaterWhite AR	1525 x 1015mm (60" x 40")	2
GL57	2mm	WaterWhite AR	1725 x 1220mm (68" x 48")	2
GL62	3mm	WaterWhite AR	2160 x 1600mm (85" x 63")	-

				Pack Qty
TVAR1008	Tru Vue	WaterWhite AR	254 x 203mm (10" x 8")	5
TVAR1210	Tru Vue	WaterWhite AR	305 x 254mm (12" x 10")	5
TVAR1612	Tru Vue	WaterWhite AR	406 x 305mm (16" x 12")	5
TVAR2016	Tru Vue	WaterWhite AR	508 x 406mm (20" x 16")	5
TVAR2420	Tru Vue	WaterWhite AR	610 x 508mm (24" x 20")	5

Can be supplied:

- By the box
- In single sheets
- Cut to size

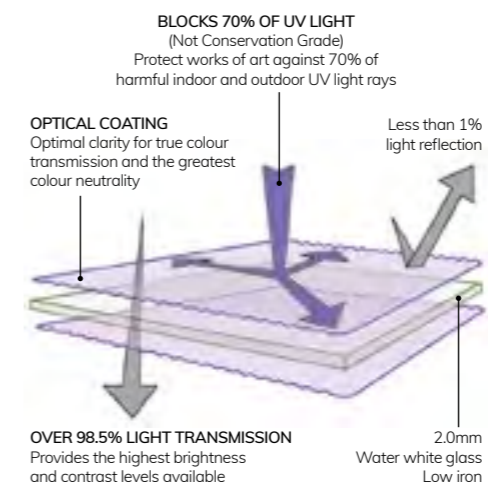



Standard Glass

UltraVue® UV92



UltraVue® UV92

Tru Vue® Anti-Reflective Coating Technology on Water White Glass with enhanced UV protection

UltraVue® UV92 glass features:

- Anti-reflective - almost invisible
- Amazing clarity • Enhanced cleanability
- 92%* UV filtering • >98.5% light transmission
- Water white glass
- Less than 1% light reflection

Use for:

- Custom framing items that will be displayed in controlled light environment to limit UV exposure
- Items that can be reproduced or replaced easily

Tru Vue UltraVue® UV92

				Box Qty
GL61	2mm	UV92 AR	1220 x 915mm (48" x 36")	2
GL611	2mm	UV92 AR	1525 x 1015mm (60" x 40")	2
GL612	2mm	UV92 AR	1725 x 1220mm (68" x 48")	2
GL613	3mm	UV92 AR	2160 x 1600mm (85" x 63")	-

Can be supplied:

- By the box • In single sheets • Cut to size

*This glass stops transmission of UV light by reflection and is angle dependent. The UV block quoted for this glass of 92% is measured for light striking the glass at an angle of 90 degrees. When light striking the glass at all angles is measured the overall block is approx. 86%. All UV blocking percentages are measured over the 300 – 380nm wavelength range.

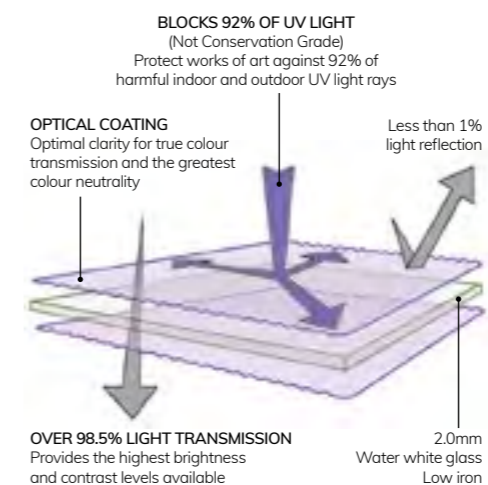



Standard Glass

UltraVue® Laminated



UltraVue® Laminated

Tru Vue® Anti-Reflective Coating Technology on Water White Glass with added safety and UV protection

UltraVue® Laminated glass features:

- Anti-reflective - almost invisible
- Amazing clarity
- Advanced scratch resistance
- Enhanced cleanability
- 99%* UV filtering
- >98.5% light transmission
- Water white glass
- Less than 1% light reflection
- Shatter resistant

Tru Vue UltraVue® Laminated

				Box Qty
GL58	4.4mm	WaterWhite Laminated	2160 x 1600mm (85" x 63")	2
GL59	8.8mm	WaterWhite Laminated	3050 x 1830mm (120" x 73")	2

Can be supplied:

- By the box
- In single sheets
- Cut to size

*This glass stops transmission of UV light by absorption and is NOT angle dependent. The UV block quoted for this glass of 99% is the actual percentage UV block. All UV blocking percentages are measured over the 300 – 380nm wavelength range.

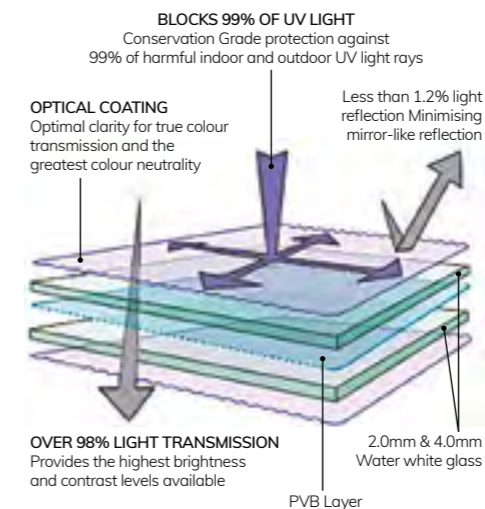



Standard Glass

Conservation Clear® Glass



Conservation Clear®

99%* UV protection, this ultra protective glass slows the rate of deterioration from UV rays

Conservation Clear® glass features:

- Conservation grade 99%* UV protection
- 8% light reflection
- Enhanced cleanability
- >89% light transmission
- 2.5mm glass substrate

Use for:

- Framing works of art and limited edition prints
- Protecting items of sentimental or monetary value

Tru Vue® Conservation Clear

				Box Qty
GL50	2.5mm	Conservation Clear	1220mm x 915mm (48" x 36")	4
GL51	2.5mm	Conservation Clear	1525mm x 1015mm (60" x 40")	2
GL501	2.5mm	Conservation Clear	1725mm x 1225mm (68" x 48")	2

Can be supplied:

- By the box
- In single sheets
- Cut to size

*This glass stops transmission of UV light by absorption and is NOT angle dependent. The UV block quoted for this glass of 99% is the actual percentage UV block. All UV blocking percentages are measured over the 300 – 380nm wavelength range.

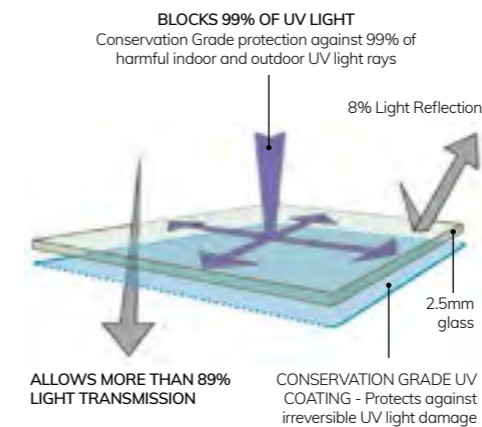



Standard Glass

Museum Glass®



Museum Glass®

Combines Tru Vue® Anti-Reflective and Conservation Grade UV Coating Technologies

Museum Glass® features:

- Conservation grade 99%* UV protection
- Anti-reflective - almost invisible • Amazing clarity
- Less than 1% light reflection
- >97% light transmission
- 2.5mm glass substrate
- Enhanced cleanability and durability

Use for:

- Protecting items of sentimental or monetary value
- Shadowboxes for displaying heirlooms and mementos
- Highly detailed and colourful works of art

Tru Vue® Museum

				Box Qty
GL53	2.5mm	Museum	1220mm x 915mm (48" x 36")	4
GL54	2.5mm	Museum	1525mm x 1015mm (60" x 40")	2
GL541	2.5mm	Museum	1725mm x 1225mm (68" x 48")	2

Can be supplied:

- By the box • In single sheets • Cut to size

*This glass stops transmission of UV light by absorption and is NOT angle dependent. The UV block quoted for this glass of 99% is the actual percentage UV block. All UV blocking percentages are measured over the 300 – 380nm wavelength range.

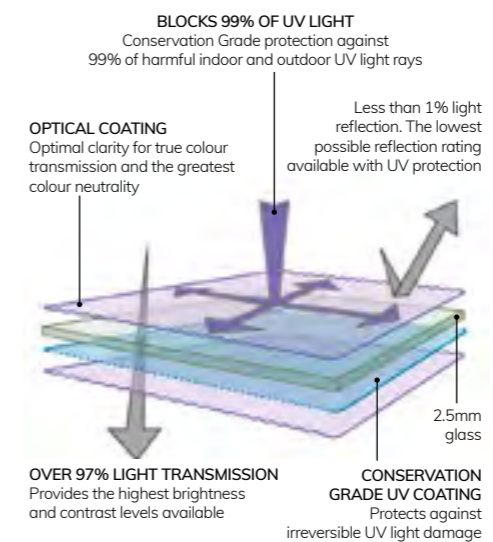



Standard Glass

Reflection Control® Glass



Reflection Control®

With its matte finish, this glass is able to scatter light and diminish unwanted glare. Perfect for items that will be displayed in controlled light environment to limit UV exposure

Reflection Control® glass features:

- 45% UV filtering
- Non-glare etched finish
- 8% scattered light reflection
- 89% light transmission
- 2.5mm glass substrate

Use for:

- Items that are not sensitive to UV damage
- Items that will be displayed in controlled light environments to limit UV exposure
- Items that can be reproduced or easily replaced

Tru Vue® Reflection Control

GL60 2.5mm Reflection Control 1220mm x 915mm (48" x 36")

Box Qty

4

Can be supplied:

- By the box
- In single sheets
- Cut to size

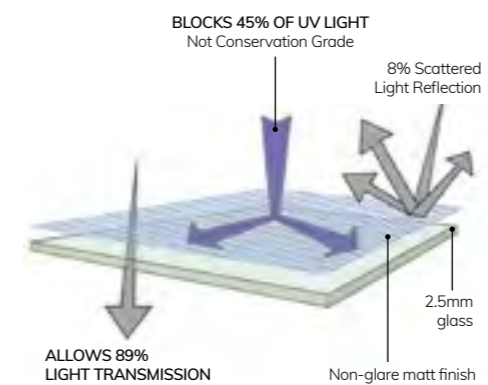



Standard Glass Conservation Reflection Control® Glass



Conservation Reflection Control®

This ultra protective glass scatters and diffuses light to reduce unwanted glare and protect against UV damage

Conservation Reflection Control® glass features:

- Conservation grade 99%* UV protection
- Non-glare etched finish
- 8% scattered light reflection
- 89% light transmission
- 2.5mm glass substrate

Use for:

- Limited edition prints, original works of art and posters
- Reducing glare in rooms with a high volume of uncontrolled light
- Items that don't require a lot of depth

Tru Vue® Conservation Reflection Control

				Box Qty
GL52	2.5mm	Conservation Reflection Control	1220mm x 915mm (48" x 36")	3
GL522	2.5mm	Conservation Reflection Control	1525mm x 1015mm (60" x 40")	2

Can be supplied:

- By the box
- In single sheets
- Cut to size

*This glass stops transmission of UV light by absorption and is NOT angle dependent. The UV block quoted for this glass of 99% is the actual percentage UV block. All UV blocking percentages are measured over the 300 – 380nm wavelength range.

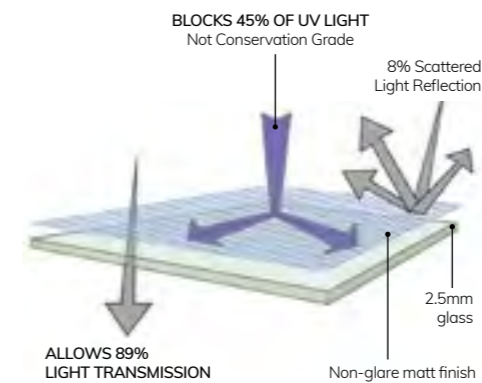

Specialist Glass

Art Glass®



Artglass AR70™	Virtually invisible glass
Artglass AR92™	Virtually invisible glass, enhanced UV protection
Artglass AR99WW™	Virtually invisible glass, maximum UV protection
Artglass AR99 Protect™	Virtually invisible glass, max UV protection, safety
Artglass UV99™	Maximum UV protection



Standard Glass

Artglass AR70™

artglass

Artglass AR70™

Appreciated worldwide for its consistent quality and clarity

Artglass AR70™ features:

- Uses a water white low iron glass and a multi layer coating to reduce reflections to approx. 1%
- Reflection colour is designed to be neutral and stable under varying viewing angles
- The anti-reflective coatings provide an ultra-smooth and durable glass surface, for improved handling and cleanability
- Reflection <1-1.5%
- Light transmission >98.5%
- UV block 70%
- 2mm and 3mm thickness

Use for:

- Reproducible artworks and photography
- Artworks that don't require conservation grade UV protection
- Controlled light environments

Artglass AR70™

				Box Qty
GL301	2mm	Artglass AR70	1100 x 800mm (43" x 31")	6
GL30	2mm	Artglass AR70	1219 x 914mm (48" x 36")	4
GL371	2mm	Artglass AR70	1600 x 1100mm (63" x 43")	4
GL37	2mm	Artglass AR70	1600 x 1200mm (63" x 47")	4
GL303	2mm	Artglass AR70	2050 x 1219mm (80 ³ / ₄ " x 48")	2*
GL38	3mm	Artglass AR70	2160 x 1570mm (85" x 61")	-

Can be supplied:

- By the box • In single sheets • Cut to size

*Only available by the pack of 2 sheets



Standard Glass

Artglass AR92™

artglass

Artglass AR92™

Used where the clarity and trueness of colour are paramount and the danger of UV damage is present

Artglass AR92™ features:

- Uses a water white low iron glass and a multi layer coating to reduce reflections to approx. 1%
- Blocks up to 92%* UV light (300 - 380nm) whilst maintaining total clarity
- Reflection colour is designed to be neutral and stable under varying viewing angles
- The anti-reflective coatings provide an ultra-smooth and durable glass surface, for improved handling and cleanability
- Reflection <1-1.5%
- Light transmission >98.5%
- UV block 92%*
- 2mm and 3mm thickness

Use for:

- Detailed artworks and photography
- Artworks that don't require conservation grade UV protection
- Controlled light environments

Artglass AR92™

				Box Qty
GL32	2mm	Artglass AR92	1219 x 914mm (48" x 36")	4
GL33	2mm	Artglass AR92	1600 x 1100mm (63" x 43")	4
GL35	2mm	Artglass AR92	1600 x 1200mm (63" x 47")	4
GL39	2mm	Artglass AR92	2190 x 1570mm (85" x 61")	-

Can be supplied:

- By the box • In single sheets • Cut to size

*This glass stops transmission of UV light by reflection and is angle dependent. The UV block quoted for this glass of 92% is measured for light striking the glass at an angle of 90 degrees. When light striking the glass at all angles is measured the overall block is approx. 86%. All UV blocking percentages are measured over the 300 - 380nm wavelength range.



Standard Glass

Artglass AR99WW™

artglass

Artglass AR99WW™

Combines the highest possible UV protection with the ultimate transparency of the low-iron glass

Artglass AR99WW™ features:

- Highest performance anti-reflective glass with 99% UV protection
- Uses a water white low iron glass
- Helps prevent treasured artwork from fading
- Ensures neutral reflection colour
- Reflection <1%
- Light transmission >97%
- UV block 99%*
- 2mm thickness

Use for:

- Original artworks
- Memorabilia with high sentimental value
- Items of organic or fading mediums

Artglass AR99WW™

				Box Qty
GL360	2mm	Artglass AR99WW	1219 x 914mm (48" x 36")	3
GL361	2mm	Artglass AR99WW	1524 x 1016mm (60" x 40")	2

Can be supplied:

- By the box
- In single sheets
- Cut to size

*This glass stops transmission of UV light by absorption and is NOT angle dependent. The UV block quoted for this glass of 99% is the actual percentage UV block. All UV blocking percentages are measured over the 300 – 380nm wavelength range.



Standard Glass

Artglass AR99™ Protect

artglass

Artglass AR99™ Protect

A shatter resistant and enduring glass, especially for larger pieces. Virtually reflection free with enhanced clarity performance

Artglass AR99™ Protect features:

- Uses a water white low iron glass and a multi layer coating to reduce reflections to approx. 1%
- Two pieces of glass are laminated together by means of a PVB plastic layer producing a safety glass. The plastic layer also provides a UV block of >99%*
- Reflection colour is designed to be neutral and stable under varying viewing angles
- The anti-reflective coatings provide an ultra-smooth and durable glass surface, for improved handling and cleanability
- Reflection <1-1.5%
- UV block 99%*
- Light transmission >98.5%

Use for:

- Framing art where protection is of the highest importance
- Items that are exhibited in high-traffic environments
- Framed items of high monetary or sentimental value

Artglass AR99™ Protect

			Box Qty
GL34	4.4mm	Artglass AR99 Protect	2190 x 1570mm (86 ¹ / ₄ " x 61 ³ / ₄ ") -

Can be supplied:

- By the box • In single sheets • Cut to size

*This glass stops transmission of UV light by absorption and is NOT angle dependent. The UV block quoted for this glass of 99% is the actual percentage UV block. All UV blocking percentages are measured over the 300 – 380nm wavelength range.



Standard Glass

Artglass UV99™

artglass

Artglass UV99™

This glass blocks out 99% of harmful UV rays slowing down the ageing and fading process, maintaining the colour and quality of your artwork

Artglass UV99™ features:

- Provides UV protection by blocking 99%* of harmful rays
- Prevents artwork from fading or paper becoming brittle
- Reflection <8%
- UV block 99%*
- Light transmission >89%

Use for:

- Limited edition prints, original works of art and posters
- Shadowboxes for displaying heirlooms and mementos
- Protecting items of sentimental or monetary value

Artglass UV99™

				Box Qty
GL391	2mm	Artglass UV99	1219 x 914mm (48" x 36")	4
GL392	2mm	Artglass UV99	1524 x 1016mm (60" x 40")	4

Can be supplied:

- By the box
- In single sheets
- Cut to size

*This glass stops transmission of UV light by absorption and is NOT angle dependent. The UV block quoted for this glass of 99% is the actual percentage UV block. All UV blocking percentages are measured over the 300 – 380nm wavelength range.

Specialist Plastic Glazing

Optium Museum Acrylic®



Tru Vue's Optium Museum Acrylic® is a premier acrylic glazing for conservation and exhibition. This virtually invisible acrylic is anti-static, anti-reflective, abrasion-resistant, and UV-filtering, making it appropriate for any project.

An optical coating on both sides of the acrylic substrate provides its unique anti-reflective properties.



Optium Museum Acrylic®

The World's Leading Plastic Glazing

Optium Museum Acrylic® Properties

UV PROTECTION	>99% between 300 - 380nm
LIGHT TRANSMISSION	>98%
REFLECTION	<1.5% for better clarity and visibility to artwork.
ACCELERATED AGEING TEST	UV protection and light transmission remain unchanged after 2000 hrs (estimated 100 years) of Q-sun Xenon arc testing at exposure intensity of 100,000 lux.
HUMIDITY RESISTANCE	MIL-C-48497A No deterioration of the coating after 48 hrs @ 50° @ 95% RH.
CORROSION (Salt Fog)	ASTM B117, B 368-03, B368-97. No deterioration of the coating after 48 hrs @ 50°C @ 95% RH. No damage to coating after exposure to 7 - 24 hour cycles.
PHOTOGRAPHIC ACTIVITY TEST	ISO 18196 Passes Silver image interaction, gelatin staining and mottling of image. ISO 18902 meets 'Photo-Safe' standards.
CHEMICAL RESISTANCE	MIL-C-48497A coating shows no signs of deterioration after 24 hrs immersion in - distilled water, saline solution, acetone, ethyl alcohol, isopropyl alcohol, coffee or coke.
OUTGASSING	No outgassing - Passed Oddy Test.
ABRASION RESISTANCE	MIL-C-14806A, PARA 4.4.7, PARA 4.4.5 & MIL- M13508C The coating shows no signs of deterioration, other than discolouration, after being subjected to 20 alcohol soaked cheesecloth tests at 2 - 2.5lbs. No damage after 600 dry cloth rubs at 2.5lbs.



Optium Museum Acrylic®

The highest specification glazing material for high value works of art, trusted by the most renowned museums

Optium Museum Acrylic® features:

- Virtually eliminates reflections
- Blocks up to 99% of UV rays
- Optimal light transmission - protects and brightens colours
- Anti-static protection that immediately dissipates static
- Durable hard coat protects against scratches
- Shatter resistant
- Cleans like glass - no special cleaners required
- Less than half the weight of glass

Use for:

- Framing or display cases
- Irreplaceable works of art
- High volume work
- Static sensitive materials
- Oversized works and structurally sensitive frames
- Shadowboxes for displaying heirlooms and momentos
- Works that travel, high traffic areas and public event spaces where safety is a concern

Tru Vue Optium Museum Acrylic®			Per
HY19	3mm	2440mm x 1220mm (96" x 48")	Sheet
HY22	4.5mm	2440mm x 1830mm (96" x 72")	Sheet
HY23	6mm	3050mm x 1830mm (102" x 72")	Sheet

Can be supplied:

- In single sheets
- Cut to size



3mm Optium Museum Acrylic®

Now available in 4 standard cut sizes with savings up to 35%



Optium Museum Acrylic® features:

- Virtually eliminates reflections
- Blocks up to 99% of UV rays
- Optimal light transmission
- Anti-static protection
- Durable hard coat protects against scratches
- Shatter resistant
- Less than half the weight of glass

Pricing and size range:

Each size is available at a set price and can be cut down to any size without a cutting charge.

If your required size is below 406 x 305mm (16" x 12") or 0.125m² please call us for a quote.

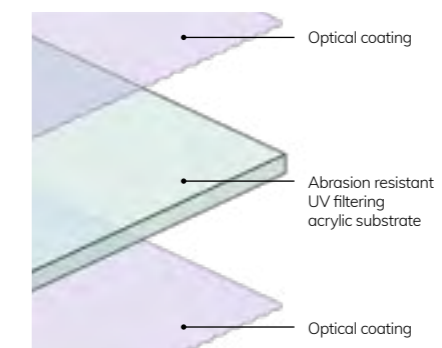

3mm Tru Vue Optium Museum Acrylic®

HY19/1 Any size between 406 x 305mm (16" x 12") and 508 x 406mm (20" x 16")

HY19/2 Any size between 508 x 406mm (20" x 16") and 508 x 610mm (20" x 24")

HY19/3 Any size between 508 x 610mm (20" x 24") and 610 x 813mm (24" x 32")

HY19/4 Any size between 610 x 813mm (24" x 32") and 813 x 1016mm (24" x 32")

All of the above can be cut down to your required size without a cutting charge



Seamed Optium Museum Acrylic®

Height 1.8m



7m

Wessex Pictures are exclusive UK distributors for SmallCorp-USA, the only company in the world that can join large sheets of Tru Vue Optium Museum Acrylic® together.

Using a bubble-free seam to create sheets larger than 3048mm x 1830mm, Seamed Optium Museum Acrylic® is perfect for antique or original frames and large pieces of artwork.

The nearly invisible seam is very strong and withstands normal handling, as well as shipping around the world.

Technological advancements over recent years has allowed us to provide our customers with seamed sheets up to: 7m x 1.8m (23ft x 6ft) and 7m x 3m (23ft x 10ft).

This 6mm thick acrylic is less than half the weight of glass, whilst still providing the best protection possible for high value works of art.



Height 3m

Seamed Optium Museum Acrylic® Illustration

7m x 1.8m (23ft x 6ft) 3 sheets of Seamed Optium Museum Acrylic®

7m x 3m (23ft x 10ft) 5 sheets of Seamed Optium Museum Acrylic®

Please note – During production a small amount of material is lost from each edge in the seaming process.



CASE STUDY

Re-glazing The Adoration of the Magi

After the full restoration of this high value tapestry, Wessex Pictures was commissioned to re-glaze the fixed wall frame that housed it.

The team removed the existing twin panels of 10mm laminated glass measuring 3.5 x 2.5m. The tapestry was then re-glazed on site with a single sheet of 6mm Seamed Tru Vue Optium Museum Acrylic®.

Wessex Pictures carried out pre-inspection site visits, a full risk assessment and provision of full liability and third party insurance. This allowed the project to proceed, and be carried out safely.



The Adoration of the Magi
Sir Edward Burne-Jones, woven by William Morris.

CASE STUDY

Pine Tree with Pheasants and Ducks

Medium: Japanese Screen (other)

Date: 17th Century

Size: 64.7 in. x 144.5 in. (164.3 cm x 367.1 cm)

Location: Taliesin, Spring Green, Wisconsin

Category: Historic House

Glazing: Seamed Optium Museum Acrylic®

Application: Framed Art

Following its recent conservation, updated framing and new glazing, the Japanese screen "Pine Tree with Pheasants and Ducks" returned to Frank Lloyd Wright's Drafting Studio at Taliesin in Spring Green, Wisconsin displayed under Tru Vue® Optium Museum Acrylic®.

SmallCorp seamed two sheets of Optium Museum Acrylic together, allowing the large, light and static sensitive artwork to be displayed safely and without distracting reflections. A National Historic Landmark that was once Wright's home and architectural studio, Taliesin houses an extensive collection of works that he purchased throughout his life.

Of the dozens of screens in the collection, "Pine Tree with Pheasants and Ducks" is one of six in the Kano School tradition in the Wright collection, most of which date to the 17th century Japan (Edo period 1603-1868).



Challenges:

- To protect the light sensitive works from dust, fading and degrading due to incoming ultra violet light.
- Large art work makes use of glass prohibitively heavy.
- Dimensions of work exceed maximum sheet size of anti-static acrylic glazing available.

Solution:

Two sheets of Optium Museum Acrylic® seamed together by SmallCorp.

- **Half the weight of glass and shatter resistant**
Safeguards against injury and damage to artwork and visitors.
- **Anti-static protection exceeds that of glass**
Makes for safer and easier framing and less cleaning.
- **Abrasion resistant**
A durable hard coat protects against scratches from cleaning and general exposure to the public.
- **Anti-reflective**
Allows viewers to see the artwork without distracting reflections.
- **99% UV blocking**
Protects the painting from the most damaging light wavelengths, helping prevent fading and degradation.

Top - Photo by Sam Anderson, Courtesy the Frank Lloyd Wright Foundation
Bottom - Photo by Kyle Dockery, Courtesy the Frank Lloyd Wright Foundation



Standard Acrylic

Clear UV Cast Acrylic

Clear UV Cast Acrylic

Clear Cast Acrylic Sheet offers the best optical clarity and is often the choice for high-quality display products

This acrylic has UV absorbers added to the polymer at the time of manufacture. The UV blocking is therefore performed by the body of the sheet and not by a coating on top of the sheet.

Clear UV Cast Acrylic features:

- Blocks up to 99% UV
- Up to 92% light transmission
- High impact resistance
- Uniform thickness
- Suitable for indoor and outdoor use
- Less than half the weight of glass
- Available cut to size

Use for:

- Positions where light reflection is an issue
- Items placed in an area susceptible to scratching or finger smudges

Clear UV Cast Acrylic

				Per
HY16	2mm	Clear UV Cast Acrylic	2030 x 1520mm (80" x 60")	Sheet
HY161	2mm	Clear UV Cast Acrylic	3050 x 2030mm (120" x 80")	Sheet
HY17	3mm	Clear UV Cast Acrylic	2030 x 1520mm (80" x 60")	Sheet
HY30	3mm	Clear UV Cast Acrylic	3050 x 2030mm (120" x 80")	Sheet



Standard Acrylic

Artshield UV

Artshield UV

Specifically designed for the art world, Artshield is a continuously manufactured UV blocking acrylic

Artshield has a scratch resistant hard coat applied to both sides. This makes it perfect for high traffic areas and where frequent cleaning is necessary.

Artshield UV features:

- Blocks up to 99%* UV
- Over 30 times the scratch resistance of normal acrylic - Double sided
- More resistant to impact than glass
- No dangerous glass splinters if broken
- Less than half the weight of glass
- Tough coatings reduce static build up
- Available cut to size

Artshield UV

				Per
HY18	3mm	Artshield UV	2440 x 1320mm (96" x 52")	Sheet

*This glass stops transmission of UV light by absorption and is NOT angle dependent. The UV block quoted for this glass of 99% is the actual percentage UV block. All UV blocking percentages are measured over the 300 – 380nm wavelength range.

Regular Glass & Plastic Glazing



We stock a large range of float glass, diffused glass, styrene and acrylic glazing products and glass sundries.

All our glass can be supplied by the sheet or cut to size and delivered by our own fleet of vans.

Float Glass

Float glass is one of the most widely used glazing options and is perfect for the busy framer.

Our 2mm float glass is interleaved with paper and available cut to size.



				Per
GL16	2mm	1220 x 915mm (48" x 36")	Sheet	
GL17	2mm	1680 x 1040mm (66" x 41")	Sheet	
GL20	2mm	1830 x 1220mm (72" x 48")	Sheet	

Cut Float Glass

Ready cut sizes from stock. Other sizes available to order. Discounts on multiple packs are available.

				Per
CG02/7x5	2mm	178 x 127mm (7" x 5")	50	
CG03/8x6	2mm	203 x 152mm (8" x 6")	50	
CG04/9x7	2mm	229 x 178mm (9" x 7")	50	
CG05/10x8	2mm	254 x 203mm (10" x 8")	50	
CG06/A4	2mm	297 x 210mm (A4)	25	
CG07/12x10	2mm	305 x 254mm (12" x 10")	25	
CG08/14x11	2mm	356 x 279mm (14" x 11")	25	
CG10/16x12	2mm	406 x 305mm (16" x 12")	25	
CG15/A3	2mm	420 x 297mm (A3)	25	
CG11/20x16	2mm	508 x 406mm (20" x 16")	20	
CG12/24x20	2mm	610 x 508mm (24" x 20")	20	
CG13/30x20	2mm	762 x 508mm (30" x 20")	10	
CG14/28x24	2mm	711 x 610mm (28" x 24")	10	

Thick Float Glass

Powdered. Available cut to size.

Thicker and larger float glass is available to order.

				Per
GL91	3mm	1830 x 1220mm (72" x 48")	Sheet	

Laminated Float Glass

Available cut to size.

				Per
GL922	4.4mm	2140 x 1320mm (84" x 52")	Sheet	

Silvered Float Glass (Mirror)

Can be ordered cut to size.

				Per
GL7	3mm	1220 x 920mm (48" x 36 1/4")	Sheet	
GL41	3mm	1830 x 1220mm (72" x 48")	Sheet	
GL4	4mm	1220 x 920mm (48" x 36 1/4")	Sheet	
GL6	4mm	1830 x 1220mm (72" x 48")	Sheet	
GL42	4mm	2440 x 1320mm (96" x 52")	Sheet	

Antique Silvered Float Glass (Mirror)

A unique hand-made mirror which simulates an antique effect whilst maintaining modern silvering standards. Bianco/Nero colour stocked.

Available cut to size.

				Per
GL45	4mm	2450 x 1220mm (96" x 48")	Sheet	
GL46	6mm	2450 x 1220mm (96" x 48")	Sheet	

Safety Backed Mirror

Comes with a film attached to the back of the mirror which helps prevent splintering if broken. Ideal for use in public areas. Available cut to size.

				Per
GL44	3mm	2140 x 1220mm (84 1/2" x 48")	Sheet	

Bevelled Mirrors

Silvered Glass with a 25mm bevelled edge. Individually wrapped. Special sizes on request.

Quantity discounts on assorted sizes:
10% for orders above 25 • 20% for orders above 50
25% for orders above 75

GL104	4mm	508 x 406mm (20" x 16")	Each
GL105	4mm	610 x 457mm (24" x 18")	Each
GL106	4mm	610 x 508mm (24" x 20")	Each
GL107	4mm	762 x 508mm (30" x 20")	Each
GL108	4mm	914 x 305mm (36" x 12")	Each
GL109	4mm	914 x 610mm (36" x 24")	Each
GL110	4mm	1219 x 305mm (48" x 12")	Each
GL111	4mm	1219 x 406mm (48" x 16")	Each
GL112	4mm	1219 x 914mm (48" x 36")	Each
GL113	4mm	1016 x 762mm (40" x 30")	Each
GL114	4mm	1219 x 610mm (48" x 24")	Each

Diffused Glass

Diffused glass is acid etched on one side to give a non glare, diffused finish. Perfect for harsh lighting conditions and reducing unwanted reflections.

Not suitable for deep box framing or multi layered mounts over 3mm.

Paper interleaved. Also available cut to size.

				Per
GL24	2mm	1220 x 915mm (48" x 36")	Sheet	
GL25	2mm	1605 x 1000mm (63" x 39 3/8")	Sheet	
GL26	2mm	1830 x 1240mm (72" x 48")	Sheet	

Plastic Glazing

Clear Acrylic

ACRYLIC (PMMA) is a clearer, harder more rigid plastic than Styrene and is used for the majority of bespoke framing work. It is available in thicknesses up to 25mm making it ideal as a safety glazing material in public areas especially where glazing weight needs to be controlled. The clarity of Acrylic is equivalent to water white glass – it does not colour the artwork. Also available cut to size.

Acrylic also comes with UV protection, anti-scratch and anti-reflective options. Please see the Specialist Glass section for these options.

Clear Extruded Acrylic

Extruded is softer than cast acrylic. It is also less optically clear but has less variation in thickness and is the cheapest of the acrylics.

Also available cut to size.

				Per
HY7	2mm	2050 x 1520mm (81" x 60")	Sheet	
HY21	2mm	3050 x 2030mm (120" x 80")	Sheet	

Clear Cast Acrylic

Cell Cast is optically clearer and harder than standard acrylic. It has more thickness variation, but this is not normally a problem for framing.

Also available cut to size.

				Per
HY9	3mm	2030 x 1520mm (80" x 60")	Sheet	
HY34	3mm	3050 x 2030mm (120" x 80")	Sheet	
HY99	5mm	3050 x 2030mm (120" x 80")	Sheet	

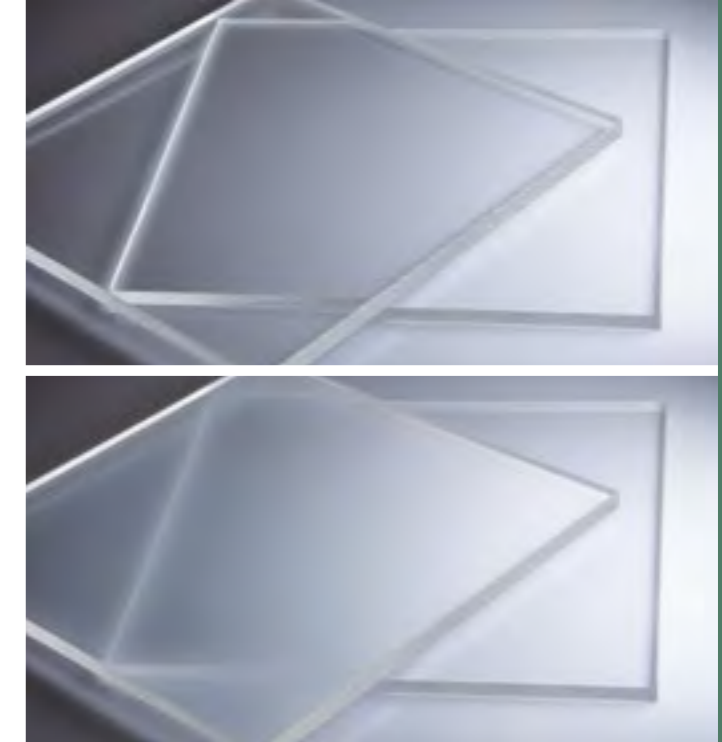

Diffused Acrylic

As clear acrylic but with a lightly diffused surface on one side. Larger sheet sizes than it's glass counterpart. Not suitable for deep box framing. Also available cut to size.

				Per
HY15	3mm	2050 x 1520mm (80" x 60")	Sheet	
HY151	3mm	3050 x 2050mm (120" x 80")	Sheet	

Clear Styrene

Clear Styrene sheet is a basic "entry level" plastic for use on non-critical images where safety glazing is required but cost is important. Styrene is relatively soft, scratches more easily and has a lower light transmission level than acrylic resulting in slight greying of the image. Also available cut to size.

				Per
HY5	1.25mm	1220 x 915mm (48" x 36")	Sheet	
HY20	1.25mm	2500 x 1250mm (98" x 49")	Sheet	
HY1	1.5mm	1220 x 914mm (48" x 36")	Sheet	
HY3	2mm	1830 x 1220mm (72" x 48")	Sheet	
HY4	3mm	1830 x 1220mm (72" x 48")	Sheet	

Diffused Styrene

As clear styrene but with a lightly diffused surface on one side. It acts the same way as diffused glass by scattering light rays that hit the surface scattering the reflected image. Not suitable for deep box framing. Also available cut to size.

				Per
HY2	1.2mm	1220 x 915mm (48" x 36")	Sheet	

Glass Cleaning

M Tork Wiping Paper

Lint free glass cleaning paper • 215mm x 275mt
Surface doesn't break up when damp

E Tork Heavy Duty Cleaning Cloth

105 lint free sheets per pack • 415 x 355mm
Exceptionally absorbent • Tough on sharp edges

Wypall Glass Cleaning Cloth

100 lint free sheets per pack • 415 x 250mm
High absorption rate

	Per
GLC1 'M' Tork Tissue	Roll
GLC3 'E' Tork Strong	Pack
GLC4 Glass Cloth	Pack

660ml Glass Cleaner Spray

Gives a smearless finish to coated glass
Suitable for all types of glass • Goes a long way
Easy to use aerosol spray

1 Litre Glass Cleaner Spray

Specially formulated glass cleaner • Non smear
Easy to use spray dispenser

5 Litre Glass Cleaner

Specially formulated glass cleaner • Non smear
Refill for 1 litre spray bottle

		Per
GMC1	660ml Glass Cleaner Spray	Can
NIL1	1 Litre Glass Cleaner Spray	1Ltr
NIL2	5 Litre Glass Cleaner Refill	5Ltr

Opti Bright Glass Cleaner

Optimum results with UV or AR coated glass.
Slow evaporation. Easy to use spray bottle.

		Per
OPTI6	Opti Bright Glass Cleaner	150ml
OPTI18	Opti Bright Glass Cleaner	450ml

Novus 1 Acrylic Cleaner

High quality acrylic plastic cleaner and polish
which also helps remove static.
Must never be used on coated products.
Apply with micro-fibre cloth.

Novus 2 Fine Scratch Remover

A polish which removes haze and fine scratches
from acrylic.
When used with Novus 1 it will restore plastic to its
original condition. It will not remove deep scratches.
Apply with micro-fibre cloth.

Micro-Fibre Cloth

400mm x 400mm professional quality micro-fibre
cloths. Ideal for glass cleaning especially speciality
glass. For best results spray cleaner directly on to
the cloth.

		Per
NOV1	High Quality Acrylic Cleaner	Bottle
NOV2	Fine Scratch Remover	Bottle
CLOTH1	Micro-Fibre Cloth	Each

Glass Sundries

Glass Cutter - Brass Handle

Silberschnitt brass handle.
High quality tungsten carbide wheel.
Ergonomically designed finger grip.
Refillable oil chamber in handle.

GC1	Glass Cutter - Brass Handle	Each
GCH1	Glass Cutter Head for GC1	Each



Glass Cutter - Plastic Handle

Toyo plastic handle • Visible oil chamber
High quality tungsten carbide wheel
Ergonomically designed finger grip

GC2	Glass Cutter - Plastic Handle	Each
GCH2	Glass Cutter Head for GC2	Each



Hand Seaming Tool

Ideal for smoothing off sharp edges. Comes with
an easy to grip plastic outer case.

HST1	Hand Seaming Tool	Each
RHS	Hand Seaming Stones	Pair
	Replacement stones for HST1	



Steel Glass Snip Off Pliers

22mm wide jaw.
Lacquered head for corrosion protection.
Drop forged head for durability.

PLIER	Steel Glass Snip Off Pliers	Each
-------	-----------------------------	------



Tape Measures

Wide blade offering greater stability.
Automatic blade locking system.
Push button retrieval.

TM3	3 Meter Tape	Each
TM5	5 Meter Tape	Each



Diamond Pad

For smoothing of sharp edges - ideal when making
clip frames. Coated with industrial diamond dust.
90mm x 55mm stiff foam.

DPG1	Diamond Pad	Each
------	-------------	------



Gripper Gloves

Latex anti-slip covering • Cotton lining

Standard Glass Gloves - Large & X Large

High cut resistance level D • Made from blended filament cut fibre • Latex crinkle coating for secure grip especially on smooth surfaces • Dry & wet grip

High Protection Glass Gloves - Large

Maximum cut resistance level F • Made from blended filament yarn with high-tensile steel • Latex crinkle coating for secure grip • Water repellent coating • Anti-bacterial treated to prevent odour

Specialist Glass Gloves - Large

High cut resistance level E • Made from Graphene fibre • Nitrile micro foam coating ideally suited to specialist glass, leaves no marks • Anti-bacterial treated to prevent odour

		Per
GG1	Gripper Gloves	Pair
GG2	Standard Glass Gloves - Large	Pair
GG3	Standard Glass Gloves - X Large	Pair
GG4	High Protection Glass Gloves - Large	Pair
GG5	Specialist Glass Gloves - Large	Pair



52" Ebonite 'T' Square

Extra hard wearing material • 1320mm
Designed specially for glass cutting
Cut out on one edge

TS52 52" Ebonite 'T' Square Each



Glass Gauntlets

Velcro fastening for quick fitting and removal • PVC cover with padded lining • Maximum cut resistance level F

Orange High Visibility Sleeve

Made from blended filament fibre • Elasticated wrist and thumb slot • Adjustable hook and loop for personal comfort • High cut resistance level D

		Per
GAU1	Glass Gauntlets	Pair
GAU2	Orange High Visibility Sleeve	Pair



Seven words to more profit

“Which type of glass would you like?”

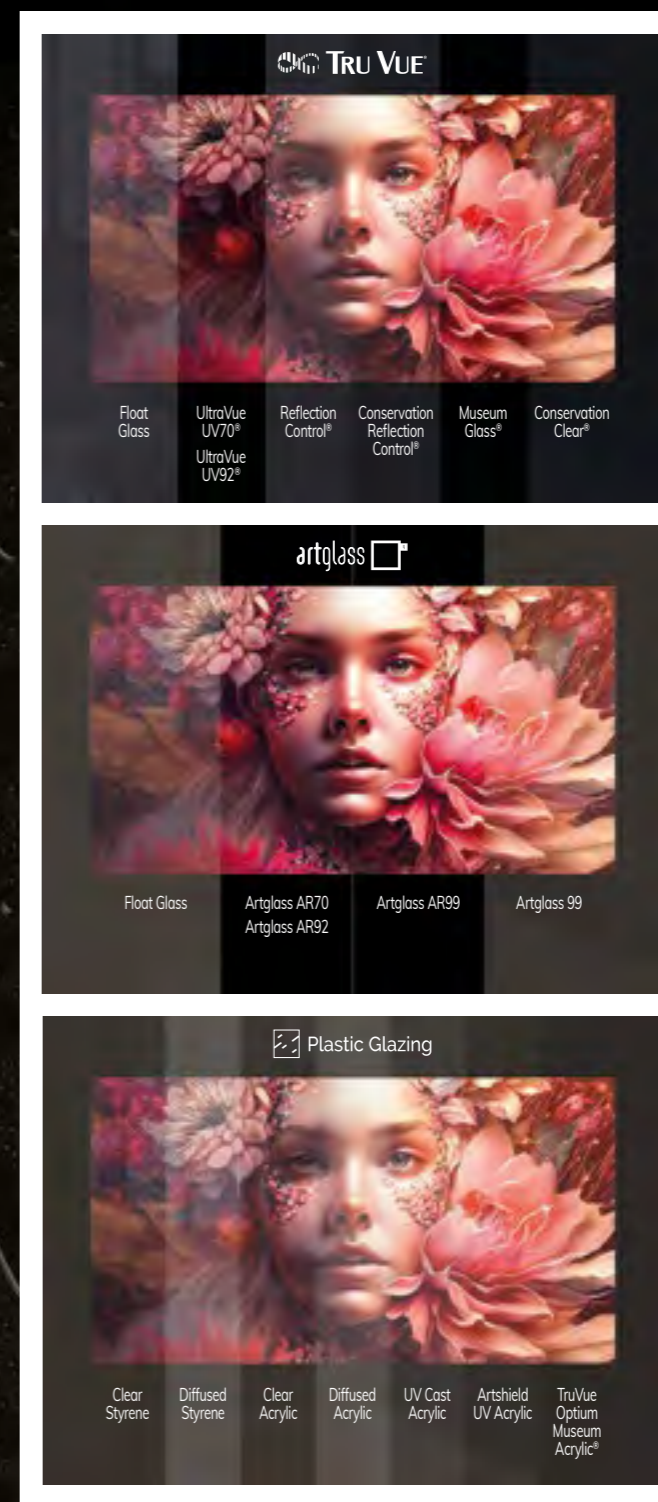

Available by the box • in single sheets • cut to size

Crescent



Manufactured to the highest standards of excellence, Crescent mountboards are classified as Good, Better and Best. Each category reflects the recommended option to suit a customer's expectations, budget and type of framing job. All of the following Crescent boards are available in single sheets.

Crescent Good Range

Standard Decorative mountboard is perfect for minimum and commended levels of framing; open end reproductions, posters decorative art and general presentation.

Features:

- Standard quality
- pH 7.5 – 8.5
- Acid-free surface, core and backing paper
- Buffered with calcium carbonate to an alkaline reserve of 2 – 5%
- FATG Mountboard Level 3
- Sizes at 1020 x 815 / 1200 x 815 and 1520 x 1020mm



White Core.102

1400µ 1020 x 815mm (40" x 32") Per Sheet

- Very White SRM918
- Canvas SRM500
- Astral White SRM945
- Arctic White SRM3297
- Off White SRM3343
- Manor White SRM3340
- Palm Beach White SRM987
- White SRM960
- Winter White SRM3354















- Snow White SRM3290
- White Linen SRM2960
- Antique White SRM3293
- Pompano Beach White SRM1000
- White & Cream SRM33
- Spice Ivory SRM1028
- Ivory SRM1008
- Wheat SRM1029
- Cream SRM961
- Cream Linen SRM2961

- Antique Buff SRM1095
- French Buff SRM3291
- Light Jonquil SRM1009
- Yellow SRM902
- Golden SRM3571
- Chamois Gold SRM994
- Topaz SRM3319
- Saffron SRM3320
- Peach SRM991
- Olde Grey SRM1014
- Olde Tan SRM1051
- Sandstone SRM1061
- Sand SRM948
- Saddle Tan SRM983
- Pewter SRM1090
- Rattan SRM3387
- Pyro Brown SRM985
- Black Walnut SRM3349
- Fudge SRM1097









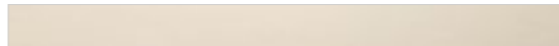
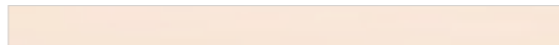

- Sable SRM997
- Sepia SRM1096
- Classic Brown SRM1040
- Mandarin SRM3325
- Burnt Orange SRM1077
- Redwood SRM1057
- Williamsburg Red SRM1042
- Auburn SRM1039
- Red SRM900
- Chinese Red SRM3214
- Crimson SRM1023
- Maroon SRM1038
- Madagascar Pink SRM1078
- English Rose SRM909
- Grey Violet SRM1015
- Concord SRM1016
- Biscay Blue SRM1073
- French Blue SRM972
- Delft Blue SRM1053

White Core.102

1400µ 1020 x 815mm (40" x 32") Per Sheet

-  Newport Blue SRM977
-  Indigo SRM3358
-  Lapis SRM3326
-  Volcano Blue SRM1081
-  Marine Blue SRM1082
-  China Blue SRM3360
-  Sheer Blue SRM3369
-  Baltic Blue SRM1054
-  Williamsburg Blue SRM1047
-  Dusty Blue SRM1024
-  Bimini Blue SRM1080
-  Aqua Green SRM3357
-  Real Teal SRM3323
-  Dusk SRM979
-  Congo Green SRM978
-  Art Deco Green SRM3328
-  Kelly Green SRM993
-  Ivy Green SRM919







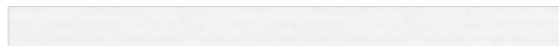
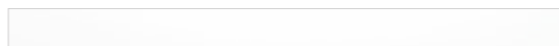
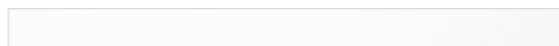
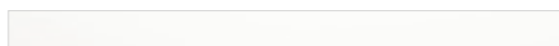
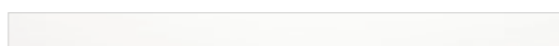
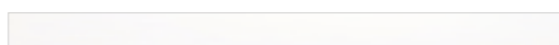

-  Dark Green SRM939
-  Williamsburg Green SRM988
-  Black Watch SRM3333
-  Grass Green SRM1045
-  Avocado SRM1084
-  Moss Point Green SRM1001
-  Green Apple SRM3364
-  Dark Olive SRM1032
-  Dark Umbria SRM3351
-  Light Umbria SRM3352
-  Sage SRM3331
-  Sauterne SRM1089
-  Bar Harbor Gray SRM976
-  Dawn Gray SRM974
-  Autumn Mist SRM916
-  Fog SRM915
-  Medium Gray SRM1025
-  Silver Gray SRM1027
-  Alabaster SRM3300

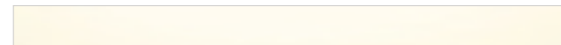
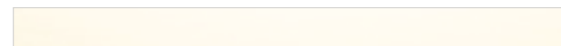
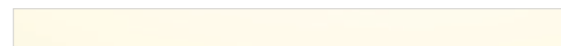
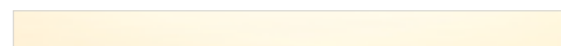
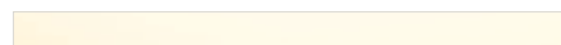
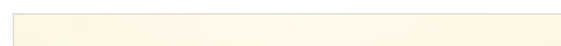
-  Pearl SRM934
-  Mist SRM1088
-  Photo Grey SRM1019
-  Cardiff SRM3536
-  Dark Gray SRM924
-  Dark Ash SRM1033
-  Black Linen SRM2921
-  Sundown Shadow SRM3359
-  Raven Black SRM989
-  Manor Black SRM3344
-  Smooth Black SRM921

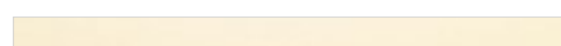
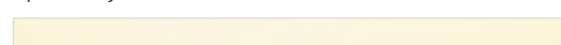
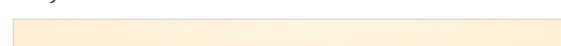
White Core.120

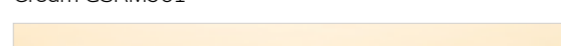
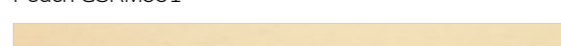
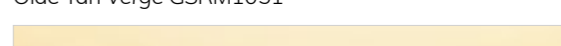
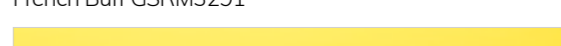
1400µ 1200 x 815mm (47¼" x 32") Per Sheet

-  Very White GSRM918
-  Canvas GSRM500
-  Script White Vergé GSRM1464
-  Astral White Vergé GSRM945
-  Arctic White GSRM3297
-  Off White GSRM3343
-  Manor White SRM3340

-  Palm Beach White GSRM987
-  White GSRM960
-  Winter White GSRM3354
-  Snow White GSRM3290
-  Warm White Vergé GSRM1450
-  Antique White GSRM3293
-  Pompano Beach White Vergé GSRM1000
-  White & Cream GSRM33
-  Spice Ivory GSRM1028
-  Ivory GSRM1008
-  Wheat GSRM1029
-  Cream GSRM961
-  Peach GSRM991
-  Olde Tan Vergé GSRM1051
-  French Buff GSRM3291
-  Yellow GSRM902
-  Chamois Gold GSRM994
-  Topaz GSRM3319
-  Saffron GSRM3320

White Core.120

1400µ 1200 x 815mm (47¼" x 32") Per Sheet



Sand GSRM948



Chinese Red GSRM3214



Crimson GSRM1023



Maroon GSRM1038



Redwood GSRM1057



Sable GSRM997



Fudge GSRM1097



Biscay Blue GSRM1073



Lapis GSRM3326



Newport Blue GSRM977



Baltic Blue GSRM1054



Dark Green GSRM939



Williamsburg Green GSRM988



Sierra Olive GSRM3414



Grass Green GSRM1045



Moss Point Green GSRM1001

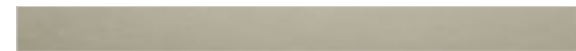

Sage GSRM3331

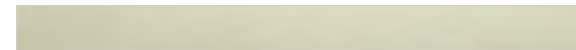

Sauterne GSRM1089



Bar Harbor Gray GSRM976

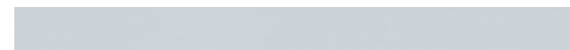

Autumn Mist GSRM916

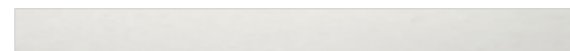

Fog GSRM915

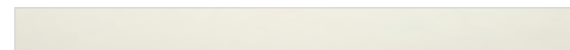

Medium Gray GSRM1025

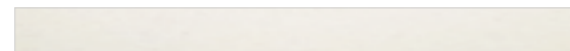

Silver Gray GSRM1027



York GSRM3425



Photo Grey GSRM1019



Cardiff GSRM3536



Dark Gray GSRM924

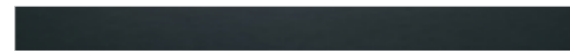

Raven Black GSRM989



Manor Black GSRM3344

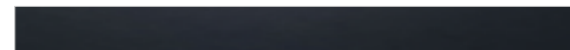

Smooth Black GSRM921

White Core.120 Extra Thick

3300µ 1200 x 815mm (47¼" x 32") Per Sheet

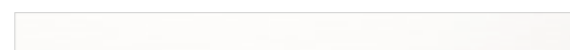

Astral White GSRM3045

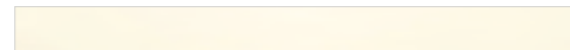

Pompano Beach White GSRM3000

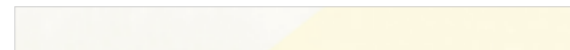

White & Cream GSRM3033



Smooth Black GSRM3021

White Core Jumbo

1400µ 1520 x 1020mm (60" x 40") Per Sheet

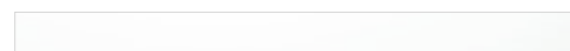

Very White SRM8918

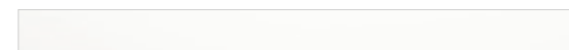

Arctic White SRM83297

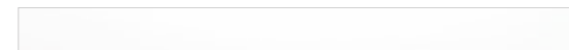

Script White Vergé SRM81464

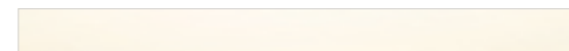

Palm Beach White SRM8987

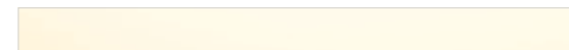

Antique White SRM83293

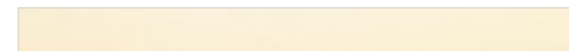

Spice Ivory SRM81028



Newport Blue SRM8977



Williamsburg Green SRM8988



Sierra Olive SRM83414



Bar Harbor Gray SRM8976

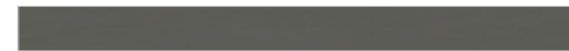

Cardiff SRM83536



Dark Gray SRM8924



Raven Black SRM8989

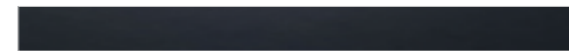

Smooth Black SRM8921

Black Core

1400µ 1020 x 815mm (40" x 32") Per Sheet

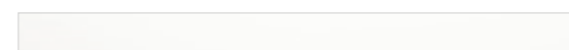

Arctic White 63297

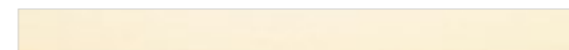

Spice Ivory 61028

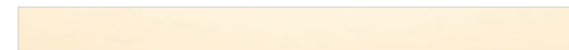

Wheat 61029



Crimson 61023



Biscay Blue 61073



Lapis 63326



Newport Blue 6977



Williamsburg Green 6988



Dark Olive 61032



Dark Ash 61033



Photo Grey 61019



Granite 63311

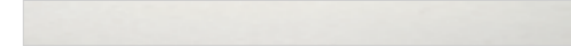

Fog 6915

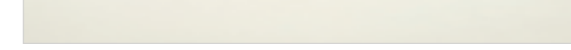

Medium Gray 61025

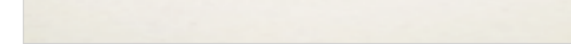

Silver Gray 61027

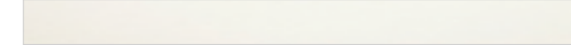

Alabaster 63300



Mist 61088



Raven Black 6989



Manor Black 63344

Black Core Thick

2200µ 1020 x 815mm (40" x 32") Per Sheet

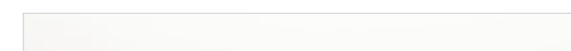

Arctic White 623297

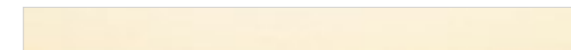

Spice Ivory 621028

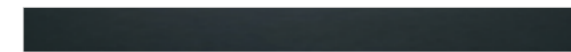

Raven Black 62989

Black Core Jumbo Per Sheet
 1400µ 1520 x 1020mm (60" x 40")

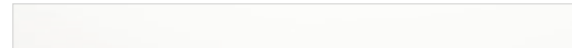

Arctic White 863297



Raven Black 86989

Artisan White Core Per Sheet
 1300 – 1500µ 1020 x 815mm (40" x 32")



Old Gold SRM968



Silver SRM969

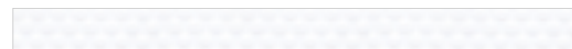

Golf Ball BW2-102

Artisan Cream Core Per Sheet
 1300 – 1500µ 1020 x 815mm (40" x 32")

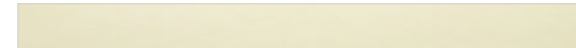

White Silki 4140



Silver Florentine 964



Earthen Off White B7-150

Artisan Black Core Per Sheet
 1300 – 1500µ 1020 x 815mm (40" x 32")



Basketball B62-100



Football B62-101

Crescent Better Range

Alpha Cellulose mountboard is perfect for conservation level framing; fine art prints, limited editions, valuable documents and photography.

Features:

- 100% alpha cellulose
- Lignin-free
- Surfaces coloured throughout with pigments
- Buffered with calcium carbonate to an alkaline reserve of 3 – 5%
- pH 8.0 – 8.5
- Ageing resistant according to DIN EN ISO 9706
- FATG Mountboard Level 2



Select.17 Per Sheet
 1700µ 1020 x 815mm (40" x 32")



White Sale CMA1702

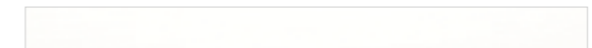

White Hot CMA1703



White Wash CMA1705

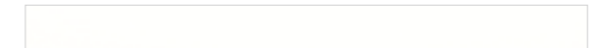

Egg White CMA1706



White Elephant CMA1707



White Sands CMA1708



Astral White CMA1745

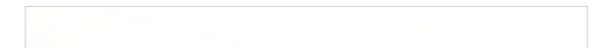

White Collar CMA1764

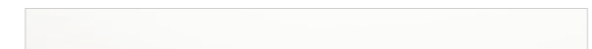

Arctic White CMA1797

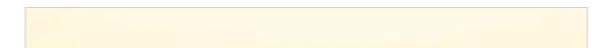

Antique Laid CMA1747

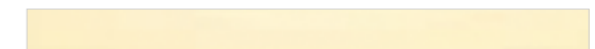

Tusk CMA1716

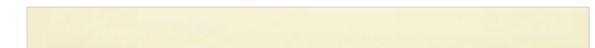

Quarry CMA1772

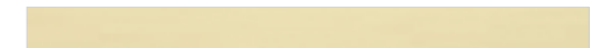

Fossil CMA1711

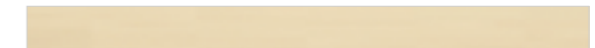

Sandpaper CMA1701

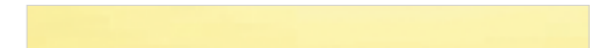

French Jonquil CMA1778



Ra CMA1715



Neaple Yellow CMA1749



Old Gold CMA1768



Royal Orchid CMA1714



Azalea CMA1744



English Rose CMA1723

The BEST Mountboard

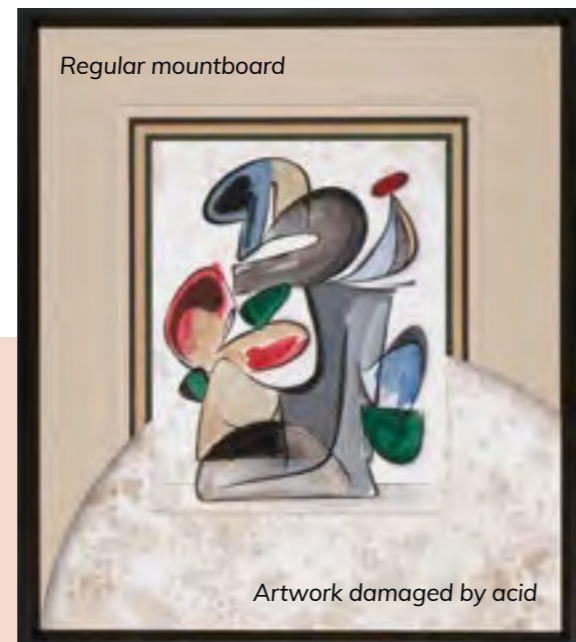
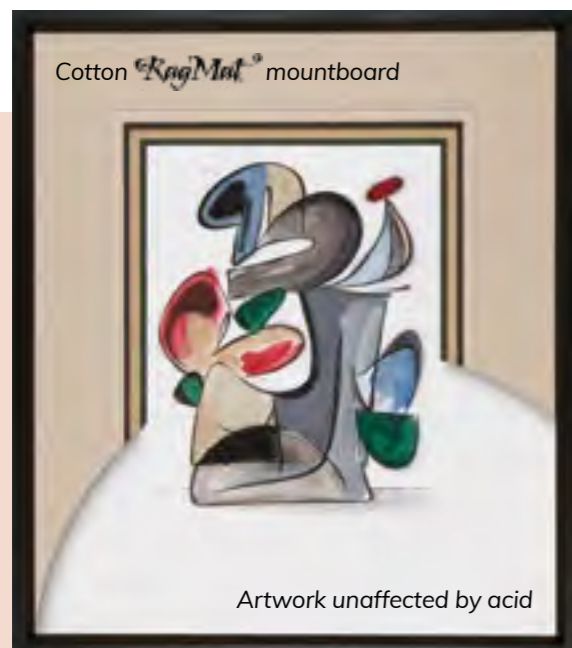

for Museum and Conservation Glazing

Crescent RagMat Museum mountboard is the best and natural choice when the highest levels of protection are required.



Select.17

1700µ 1020 x 815mm (40" x 32") Per Sheet



Light Mauve CMA1786



True Red CMA1713



Crimson CMA1725



Marooned CMA1774



Top Soil CMA1791



Nutmeg CMA1784



Haystack CMA1720

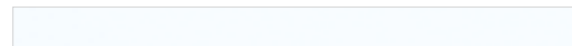

Barely Blue CMA1765



Sheer Blue CMA1766



Tuscany Blue CMA1712



Royal Blue CMA1760



Pharoah CMA1754



Moody Blue CMA1753



Blue Monday CMA1742



Bonsai CMA1733

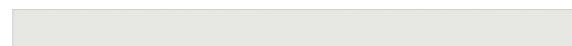

Dawn Gray CMA1775

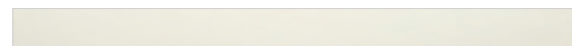

Medium Gray CMA1700

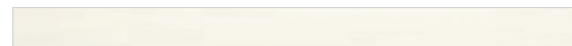

Blizzard CMA1792



Wise Green CMA1727



Deep Woods CMA1738



Bar Harbour Gray CMA1755

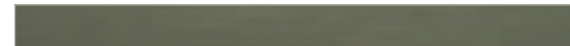

Before Dark CMA1798



After Dark CMA1721

Conservation

1500µ 1200 x 815mm (47½" x 32") Per Sheet

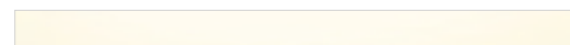

White CMAW1547

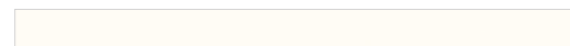

Natural CMAN1547

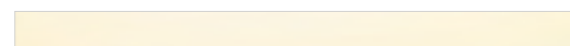

Ivory CMAI1547

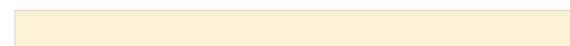

Antique CMAA1547

Conservation Thick

2000µ 1200 x 815mm (47½" x 32") Per Sheet



White CMAW2047

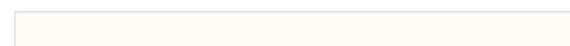

Natural CMAN2047

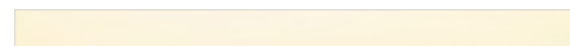

Ivory CMAI2047

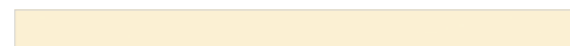

Antique CMAA2047

Conservation Extra Thick

2500µ 1200 x 815mm (47½" x 32") Per Sheet



White CMAW2547



Natural CMAN2547

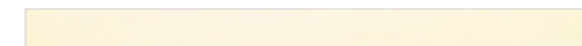

Ivory CMAI2547

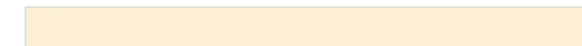

Antique CMAA2547

Conservation Jumbo

1500µ 1600 x 1200mm (63" x 47¼") Per Sheet



Natural CMAN1563

Conservation Jumbo Duo

1500µ 1620 x 1220mm (63¾" x 48") Per Sheet

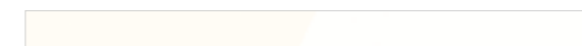

Natural and White CMANW1563

Conservation Extra Thick Jumbo Duo

2500µ 1620 x 1220mm (63¾" x 48") Per Sheet



Natural and White CMANW2563

Conservation XXL Jumbo Duo

2500µ 2440 x 1220mm (96" x 48") Per Sheet



Natural and White CMANW2596

Conservation Linen

1600µ 1020 x 815mm (40" x 32") Per Sheet



Classic Beige CMCL5520



Deep Red CMCL5527



Clasi Burgundy CMCL5534



Dark Olive CMCL5531



Noir CMCL5521

Conservation Suedes

1600µ 1020 x 815mm (40" x 32") Per Sheet



Smoke CMCS5517



Prairie CMCS5516



Thicket CMCS5515



Blaze CMCS5504



Berry CMCS5503



Treeline CMCS5500



Pine CMCS5513



Brook CMCS5501



Torrent CMCS5502



Ash CMCS5518



Night Sky CMCS5506

Etched Metals

1400µ 1016 x 815mm (40" x 32") Per Sheet



Brushed Brass CM5400



Gunmetal CM5402



Oil Rubbed Bronze CM5403

Black Core Etched Metals

1500µ 1016 x 815mm (40" x 32") Per Sheet



Gunmetal CM9949



Oil Rubbed Bronze CM9950

Britecore

1600µ 1020 x 815mm (40" x 32") Per Sheet

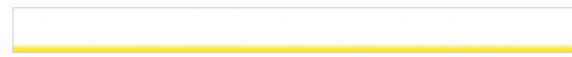

White on Yellow CMBR44987



White on Orange CMBR54987



White on Red CMBR34987



White on Pink CMBR74987



White on Purple CMBR64987



White on Blue CMBR14987



White on Aqua CMBR84987



White on Green CMBR24987



Black on Yellow CMBR44921



Black on Orange CMBR54921



Black on Red CMBR34921



Black on Pink CMBR74921



Black on Purple CMBR64921



Black on Blue CMBR14921



Black on Aqua CMBR84921



Black on Green CMBR24921

Crescent
Best Range

Cotton mountboard is perfect for museum framing; valuable works of original art, rare and antique documents, fine art prints and valuable photographs.

RagMat Museum Solids features:

- Museum quality made of 100% cotton
- 100% lignin and spot free
- Coloured throughout with pigments
- Buffered with calcium carbonate to an alkaline reserve of 2 – 5%
- pH 7.5 – 9.5
- PAT tested
- FATG Mountboard Level 1

RagMat Museum Unbuffered features:

- As above but unbuffered
- pH 7.0 – 7.5

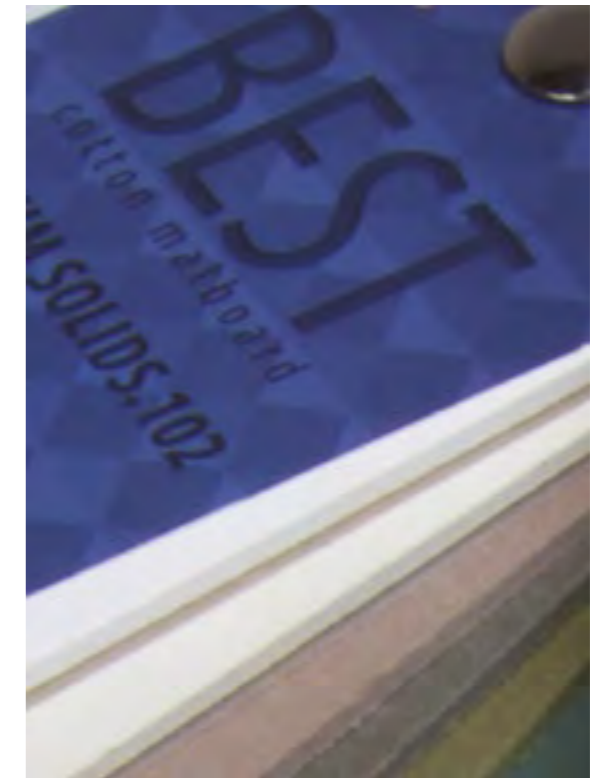

RagMat Museum Duplex features:

- Double-sided cotton board with a different colour on each side

RagMat Museum Solids

1500µ 1020 x 810mm (40" x 32") Per Sheet

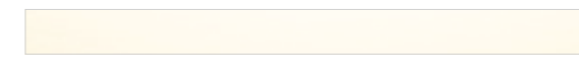

Archival Mist CM1100

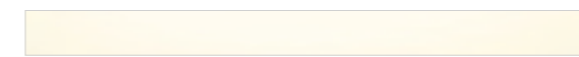

Winter White CM1170



White CM2253

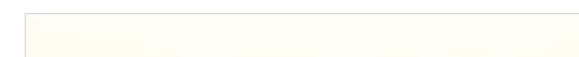

Sand Dollar CM1126

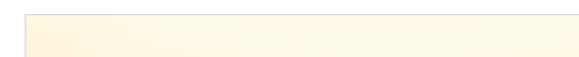

Soft White CM1112

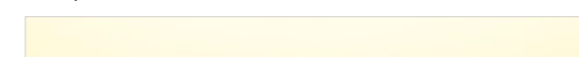

Antique White CM2259

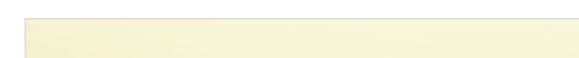

Cream CM2255



Soft Cream CM1173



Almond CM1114

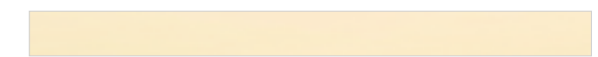

Antique Tan CM1104

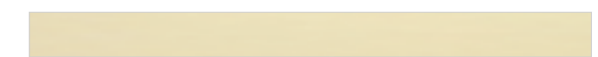

Shoreline CM1128

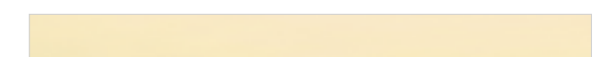

Clay CM1175

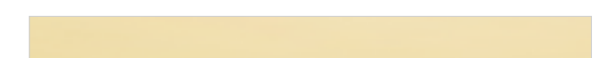

Bluff CM1129



Desert Sand CM1105

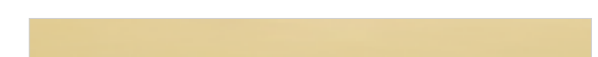

Suntan CM1176

Break the Mould
on your next framing job

Make the break from traditional black, white or cream mountboards.

Offer your customers exciting colours and textures which will enhance their artwork even further.



wessexpictures.com



RagMat Museum Solids

1500μ 1020 x 810mm (40" x 32") Per Sheet

- Sanguine CM1189
- Shetland CM1125
- Inverness CM1121
- Sprout CM1127
- Stratford CM1122
- Fieldstone CM1137
- Loam CM1136
- Sable CM1184
- Antique Gray CM1106
- Vintage Gray CM1102
- Neutral Gray CM1101
- Essential Gray CM1187
- Cool Gray CM1186
- Briar CM1133
- Gray CM1117
- New Castle CM1123
- Black CM1115

RagMat Museum Solids Thick

2500μ 1020 x 815mm (40" x 32") Per Sheet

- White CM1536
- Winter White CM21188
- White CM2238
- Sand Dollar CM21126
- Soft White CM21112
- Antique White CM2239
- Cream CM22255
- Antique Gray CM21106
- Antique Tan CM21104
- Black CM21115

RagMat Museum Solids Jumbo

1500μ 1520 x 1020mm (60" x 40") Per Sheet

- Winter White CM81188
- White CM2262
- Sand Dollar CM81126
- Soft White CM81112
- Antique White CM2260
- Cream CM2261

- Inverness CM81121
- Almond CM81114
- Antique Gray CM81106
- Antique Tan CM81104
- Desert Sand CM81105
- Black CM81115

Museum Solids Extra Thick Jumbo

3000μ 1520 x 1020mm (60" x 40") Per Sheet

- White CM2268
- Winter White CM821188
- Soft White CM821112
- Antique White CM82239
- Black CM821115

RagMat Museum Solids XL Jumbo

1500μ 1830 x 1220mm (72" x 48") Per Sheet

- White CM2263
- Antique White CM2269
- Museum Solids XL Extra Thick Jumbo
- White CM22263
- Antique White CM22269

RagMat Museum Solids XXL Jumbo

1500μ 2440 x 1220mm (96" x 48") Per Sheet

- White CM2273
- Antique White CM2279
- Black CM2275

Museum Solids XXL Extra Thick Jumbo

3000μ 2440 x 1220mm (96" x 48") Per Sheet

- White CM22273

RagMat Museum Solids XXXL Jumbo

1500μ 2640 x 1520mm (104" x 60") Per Sheet

- White CM2283
- Antique White CM2289

RagMat Museum Solids Unbuffered

1500μ 1020 x 810mm (40" x 32") Per Sheet

- White CM2299
- Antique White CM2298
- Cream CM2297
- Optic Black CM2296

RagMat Museum Solids Duplex

1140μ 1020 x 810mm (40" x 32") Per Sheet

- Duplex boards can be used both sides giving you two options in one board.
- White and Antique White CM1530
- Off White and Cream CM1531

Larson Juhl



Across Solidcore, Blackcore, Conservation and Whitecore, Larson Juhl offer a comprehensive range of Mountboard and are all available in single sheets.

LARSON · JUHL® Conservation

Features:

- FATG Mountboard Level 2
- Acid and lignen-free surface paper
- High quality alpha-cellulose core
- Buffered with calcium carbonate to guard against contamination

Conservation

1400µ 1120 x 815mm (44" x 32") Per Sheet

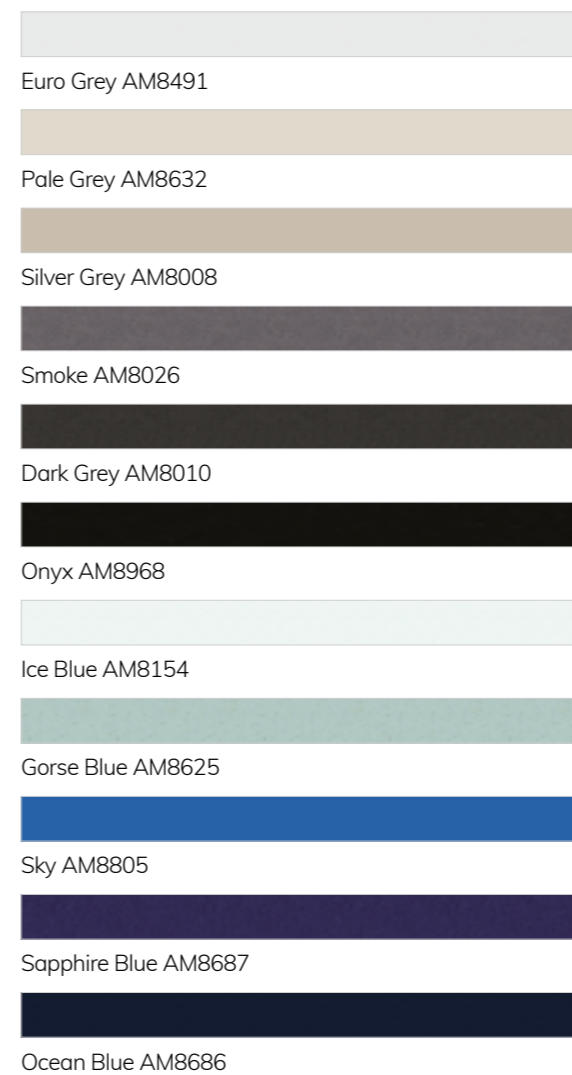

Conservation

1400µ 1200 x 800mm (47" x 31") Per Sheet

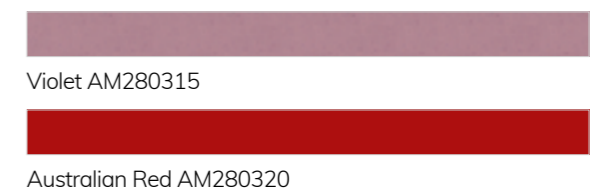
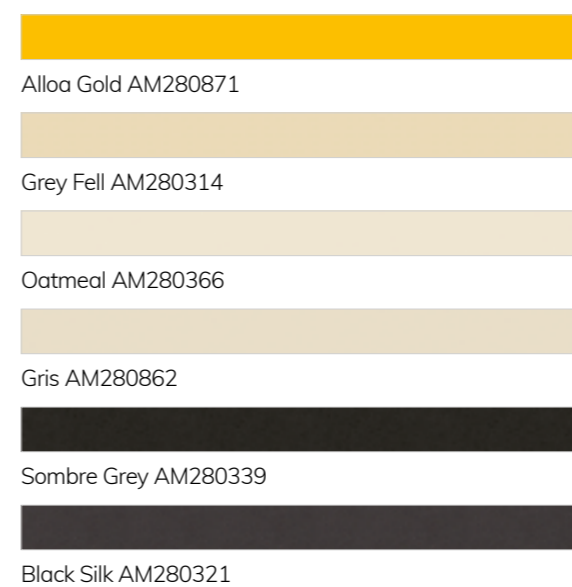

Conservation Thick

2400µ 1120 x 815mm (44" x 32") Per Sheet

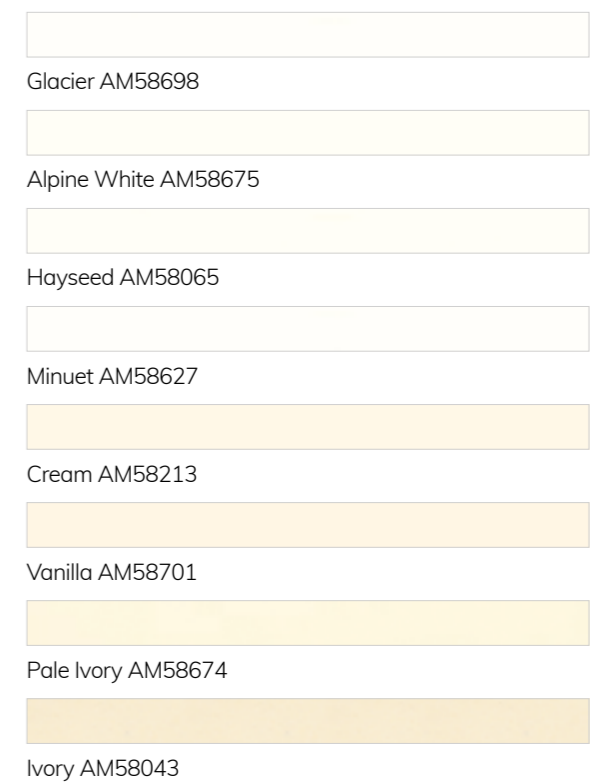

Conservation Extra Thick

3500µ 1120 x 815mm (44" x 32") Per Sheet

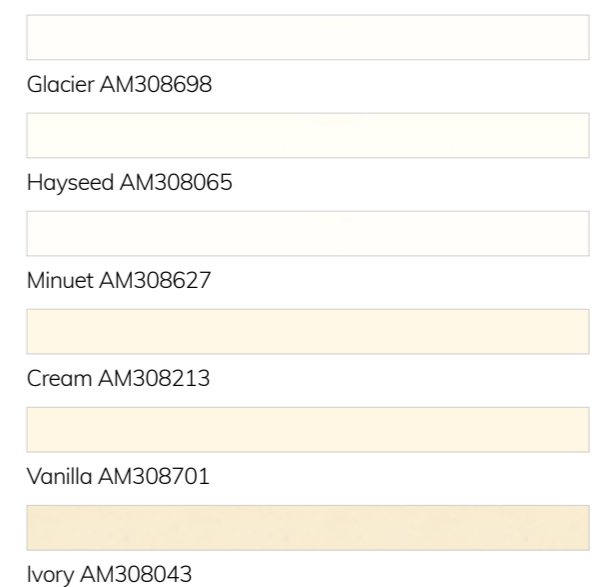

Conservation Jumbo

1400µ 1630 x 1120mm (64" x 44") Per Sheet



Glacier AM89698



Hayseed AM89065



Minuet AM89627

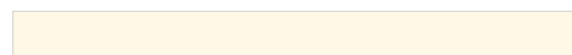

Cream AM89213

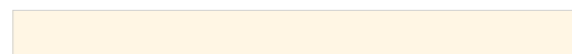

Vanilla AM89701

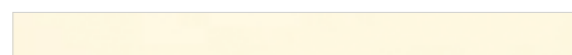

Pale Ivory AM89674

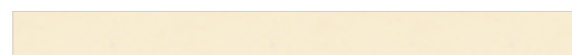

Ivory AM89043

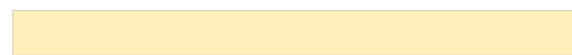

China White AM89002

Conservation Linen

1500µ 1020 x 815mm (40" x 32") Per Sheet

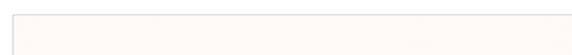

Icicle AM8500



Calla AM8502



Mohair AM8503



Moccasin AM8504



Gingersnap AM8505



Saddle AM8507



Twilight AM8508

LARSON · JUHL® Whitecore

Features:

- FATG Mountboard Level 3
- Acid and lignen-free surface paper (excluding metallics)
- High quality alpha-cellulose core
- Buffered with calcium carbonate to guard against contamination

Whitecore

1400µ 1120 x 815mm (44" x 32") Per Sheet

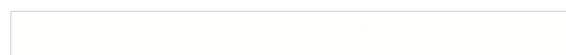

Bright White AM8977

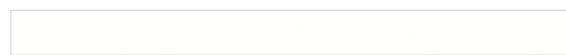

Snow White AM8001

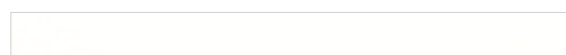

Arctic White AM8223



Photo White AM8278

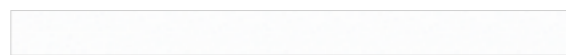

Avillon White AM8661

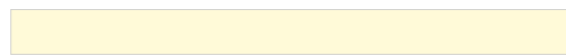

Old Ivory AM8629

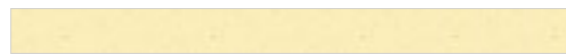

Andover Cream AM8626



Deep Pink AM8028



Vermillion AM8020



Beaujolais AM8151



Maroon AM8016



Terracotta AM8013



Mustard Yellow AM8611

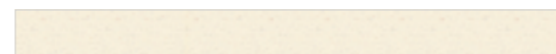

New Cream AM8003

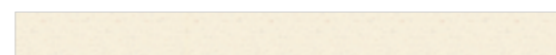

Castile Ivory AM8662



Magnolia Texture AM8608



Clay AM8613



Ginger Root AM8605



Malt AM8040



Mid Brown AM8005



Omar Brown AM8006



Spice Brown AM8023



Baghdad Brown AM8007



Sepia AM8024



Dull Green AM8019



Newbury Moss AM8058



Dark Green AM8027



Damascus Green AM8018



Olive AM8032



Sage AM8034



Moss Point Green AM8645



Green Textured AM8614

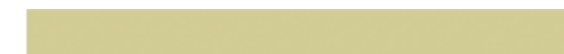

Apple Green AM8411



Guacamole AM8416



Mid Green AM8017



Congo Green AM8643



Grasmere Green AM8616



Pale Green AM8030

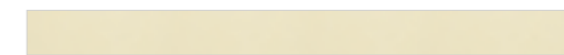

Elise Green AM8618



Dawn Green AM8635



Dawn Grey AM8070



Aragon Grey AM8664

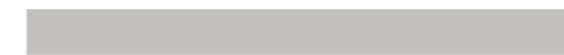

Mid Grey AM8045



Stone AM8052



Monument Grey AM8055



Slate Grey AM8159



Terazzo Grey AM8666



Black AM8011



Moussaka AM8816



Damson AM8146

Whitecore Per
1400µ 1120 x 815mm (44" x 32") Sheet



Light Blue AM8051



Alpine Blue AM8168



Mid Blue AM8053



Deep Blue Textured AM8087



Royal Blue AM8054



Silurian Blue AM8014



Dark Blue AM8071



Imperial Blue AM8640



Gold Metallic AM8246



Silver Metallic AM8358

Whitecore Thick Per
2400µ 1120 x 815mm (44" x 32") Sheet

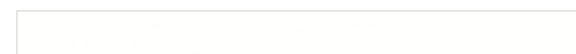

Bright White AM58977

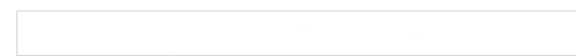

Snow White AM58001

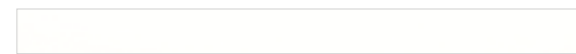

Arctic White AM58223

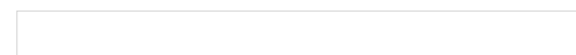
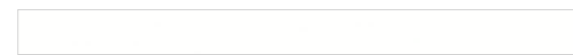

Photo White AM58278



Black AM58011

Whitecore Extra Thick Per
3500µ 1120 x 815mm (44" x 32") Sheet



Bright White AM308977



Snow White AM308001



Arctic White AM308223

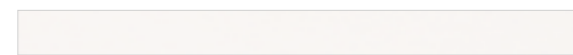

Photo White AM308278



Black AM308011

Whitecore Per
1400µ 1200 x 800mm (47" x 31") Sheet



Star White AM280378

Whitecore Jumbo Per
1400µ 1630 x 1120mm (64" x 44") Sheet

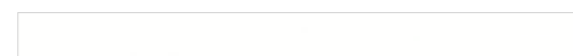

Snow White AM89001



Arctic White AM89223



Photo White AM89278



Damascus Green AM89018



Black AM89011



Silurian Blue AM89014

Whitecore Jumbo Per
1400µ 1630 x 1020mm (64" x 40") Sheet

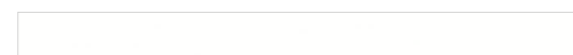

Bright White AM88977

LARSON · JUHL® Blackcore

Features:

- FATG Mountboard Level 3
- Acid and lignen-free surface paper (excluding metallics)
- Highly-refined wood pulp core
- Buffered with calcium carbonate to guard against contamination

Blackcore Per
1400µ 1120 x 815mm (44" x 32") Sheet



Bright White AM7977

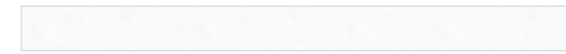

Snow White AM7001



Photo White AM7278



Hayseed AM7065



Avillon White AM7661



Ivory AM7043



Andover Cream AM7626



Castile Ivory AM7662



Vermillion AM7020



Aragon Grey AM7664



Terazzo Grey AM7666



Onyx AM7968



Black AM7011



Gold Metallic AM7246



Silver Metallic AM7358

Blackcore Jumbo Per
1400µ 1630 x 1120mm (64" x 44") Sheet



Black AM97011



UPDATED

FATG Mountboard Standards

01

QUALITY LEVEL 1
Often used names
Museum, Cotton,
100% Cotton, Rag

02

QUALITY LEVEL 2
Often used names
Conservation, Alpha,
Alpha Cellulose

03

QUALITY LEVEL 3
Often used names
White Core,
White Core Plus

04

QUALITY LEVEL 4
Often used names
Standard,
Cream Core

For more information, visit fineart.co.uk

LARSON · JUHL®

Solidcore

Features:

- FATG Mountboard Level 2
- Lignin-free board
- Natural pigments ensures board is fade and bleed resistant
- Buffered with calcium carbonate to guard against contamination

Solidcore Thin Per Sheet
500µ 1120 x 815mm (44" x 32")



White AM1401



Off White AM1403

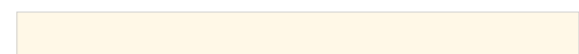

Cream AM1402

Solidcore Per Sheet
1500µ 1120 x 815mm (44" x 32")

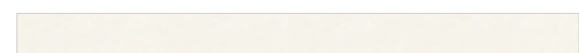

White AM401

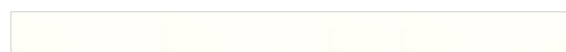

Off White AM403

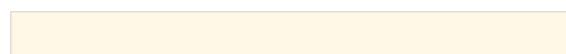

Cream AM402

Solidcore Thick Per Sheet
2200µ 1120 x 815mm (44" x 32")

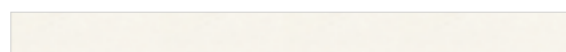

White AM4401



Off White AM4403

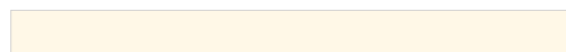

Cream AM4402

Solidcore Jumbo Per Sheet
1500µ 1630 x 1120mm (64" x 44")

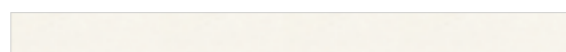

White AM9401



Off White AM9403

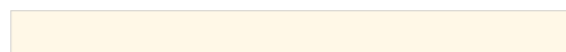

Cream AM9402

LARSON · JUHL®

Layered Core

Features:

- FATG Mountboard Level 3
- Duplex board
- Made up of 4 layers of alternate coloured board
- Gives great effect when bevelled

Layered Core Per Sheet
2400µ 1120 x 815mm (44" x 32")



Snow White / Black AM11001



Hayseed / Black AM11065

LARSON · JUHL®



Mountboard made in the UK
Our collection provides endless creative options



For more information and to access our Mountboard Selector visit
www.larsonjuhl.co.uk

Slater Harrison



Slater Harrison & Co Ltd are a UK manufacturer of beautifully crafted papers and boards. Based at their mill in Cheshire, they have been producing for over 90 years. All of the following Colourmount boards are available in single sheets.

Conservation White Core

Features:

- Will not discolour with age
- Bleed resistant
- Pure white bevel that stays white
- Alkaline pH: buffered with a calcium carbonate to a pH of 7.5 to 9.5
- FATG Level 2

Conservation White Core Per
 1400µ 1200 x 815mm (47" x 32") Sheet

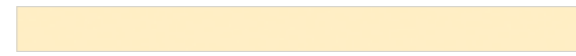

Pearl SH300



Ivory SH301



Sand SH304



Blossom SH305

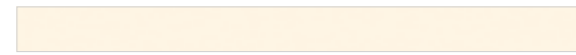

Warm Ivory SH306



Champagne SH307



Oyster SH308

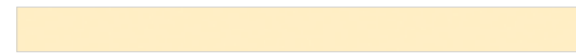

Old Ivory SH309



Beige SH310



Stone SH323



Laurel SH335



Bluebell SH340



Pastel Blue SH344



Cloud SH345



Lupin SH346

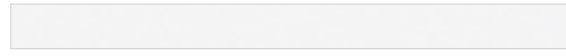

Soft White SH375



Dawn Mist SH377



Sugared Almond SH382

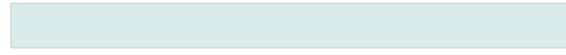

Iced Crystal SH385

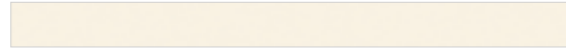

Arctic White SH389



Chalk White SH3001



Polar White SH3002



Buttermilk SH3003

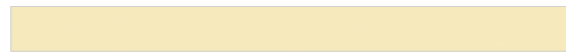

Almond SH3004



Bamboo SH3007



Vanilla SH3015



Mushroom SH3023



Eggshell SH3701



Osprey SH3725

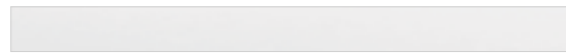

Essence White SH3917



Harvest Beige SH3920



Sandstone SH3925



Clearwater SH3951



Haystack SH3965



Iced White SH3973



Antique White SH3975



Off White SH3981



Honeysuckle SH3982



Putty SH3983



Cameo SH3984



Sand Ingres SH3985



Cream Ingres SH3986



White Ingres SH3987

Conservation White Core Thick Per
 2000µ 1200 x 815mm (47" x 32") Sheet



Chalk White SH2001



Polar White SH2002

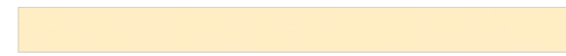

Pearl SH2300

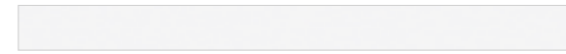

Soft White SH2375



Dawn Mist SH2377



Iced White SH2973



Antique White SH2975



Off White SH2981

Conservation White Core ExtraThick Per
 3000µ 1200 x 815mm (47" x 32") Sheet

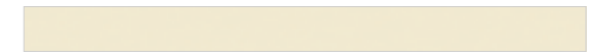

Ivory SH3301

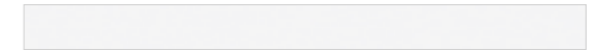

Soft White SH3375



Antique White SH33975

Conservation White Core Jumbo Per
 1400µ 1525 x 1020mm (60" x 40") Sheet

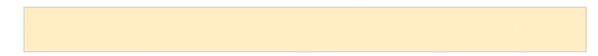

Pearl SHJ7300



Ivory SHJ7301



Beige SHJ7310

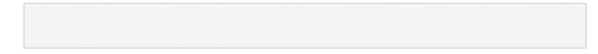

Soft White SHJ7375



Chalk White SHJ73001

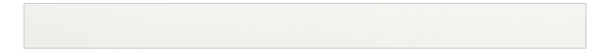

Haystack SHJ73965



Iced White SHJ73973



Antique White SHJ73975



Off White SHJ73981

Conservation White Core JumboThick Per
2000µ 1525 x 1020mm (60" x 40") Sheet

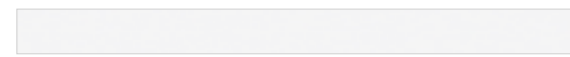

Soft White SHJU2375



Iced White SHJU2973



Antique White SHJU2975



Off White SHJU2981



White Core

Features:

- Pure white bevel that stays white
- Alkaline pH: buffered with a calcium carbonate to a pH of 7.5 to 9.5
- FATG Level 3

White Core Per
1400µ 1200 x 815mm (47" x 32") Sheet



Chocolate SH313



Sepia SH314



Seal Brown SH315



Cement SH320

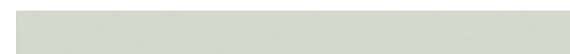

Portland SH321



Charcoal SH325



School Grey SH326



Granite SH328



Pastel Green SH329



Sage Green SH330



Moorland Green SH331



Bottle Green SH332



Holly Green SH333



Maple SH334



Pistachio SH337



Midnight SH339



Slate SH341



Cobalt Blue SH342



Oxford Blue SH343



Porcelain SH347



Beaujolais SH349



Rouge SH350



Poppy SH351



Burgundy SH353

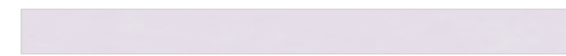

Blush SH354



Dusty Pink SH355



Pastel Pink SH356



Hazelnut SH359



Burnt Orange SH360



Silver SH361



Gold SH362



Old Gold SH364



White SH371



Black SH372



Frost SH376

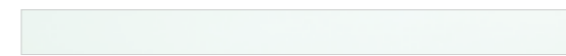

Floral White SH379



Corn silk SH380

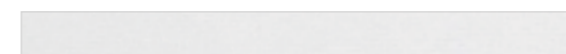

Simply White SH391



Leaf Green SH3030

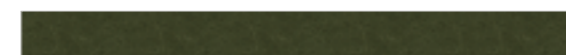

Forest Green SH3031



China Red SH3040



Ochre SH3506



Chestnut SH3720



English Rose SH3730



Grape SH390



Chive SH3931



Pigeon SH3945



Nightshade SH3954

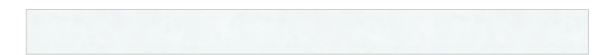

Glacier White SH3960

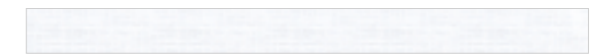

Snow White Textured SH3971



Shamrock SH3990



Emerald SH3991



Lime SH3992



Aqua SH3993



Sky SH3994



Lemon SH3995



Tangerine SH3996



Geranium SH3997



Cinder Grey SH3998



Ebony SH3999

White Core Centura Metallic Per
1400µ 1200 x 815mm (47" x 32") Sheet



White Gold SHCM11



Pale Silver SHCM12



Green Gold SHCM13



Pale Gold SHCM14



Solar Gold SHCM15



Rose Gold SHCM16



Copper SHCM17



Bronze SHCM18



Platinum SHCM19

White Core Centura Neon Per
1400µ 1200 x 815mm (47" x 32") Sheet



Yellow SHCN11



Orange SHCN22



Pink SHCN33



Red SHCN88



Green SHCN99

White Core Lustre Per
1400µ 1200 x 815mm (47" x 32") Sheet



Lily White SHLU01



Pale Ivory SHLU04



Scarlet SHLU05



Emerald SHLU06



Jet Black SHLU08

White Core Thick Per
2000µ 1200 x 815mm (47" x 32") Sheet



White SH2371



Black SH2372

White Core Extra Thick Per
3000µ 1200 x 815mm (47" x 32") Sheet



Black SH3372

White Core Jumbo Per
1400µ 1525 x 1020mm (60" x 40") Sheet



Seal Brown SHJ7315



Portland SHJ7321



Charcoal SHJ7325



Bottle Green SHJ7332



Midnight SHJ7339



Oxford Blue SHJ7343



Old Gold SHJ7364



White SHJ7371

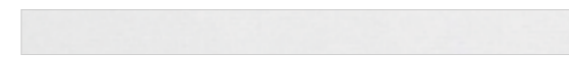

Simply White SHJ7391



Black SHJ7372



Platinum SHJCM19



Black Core

Features:

- Solid black core
- Alkaline pH: buffered with a calcium carbonate to a pH of 7.5 to 9.5
- FATG Level 3

Black Core Per
1250µ 1125 x 815mm (44¼" x 32") Sheet



Osprey SH405



Chalk White SH411



Polar White SH412



Seal Brown SH415



Bamboo SH417



Mushroom SH423



Charcoal SH425



Forest Green SH431



Laurel SH435

White Core Jumbo Thick Per
2000µ 1525 x 1020mm (60" x 40") Sheet



White SHJU2371



Black SHJU2372



China Red SH440



Cobalt Blue SH442



Beaujolais SH449



Dusty Pink SH455



White SH471



Solid Black SH472



Sand Ingres SH485



Cream Ingres SH486



White Ingres SH487



Simply White SH491



Solar Gold SHBCCM15



Copper SHBCCM17



Platinum SHBCCM19

Black Core Jumbo Per
1250µ 1525 x 1020mm (60" x 40") Sheet



Black SHJBC472

Monochrome White Per
 Varied 1200 x 815mm (47" x 32") Sheet



2.3mm White / Black / White SHMC23W



3.4mm White / Black / White SHMC34W

Monochrome Black Per
 Varied 1200 x 815mm (47" x 32") Sheet



2.8mm Black / White / Black SHMC28B



3.4mm Black / White / Black SHMC34B



Archival

Features:

- Fade and bleed resistant
- Alkaline pH
- FATG Level 2

Archival Per
 1350µ 1125 x 815mm (44" x 32") Sheet



Ivory SH601



Orchid SH605



White SH671

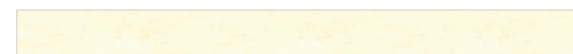

Off White SH681

Archival Barrier Per
 450µ 1125 x 815mm (44" x 32") Sheet

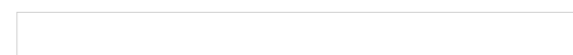

White SH2671

Archival Extra Thick Per
 3200µ 1125 x 815mm (44" x 32") Sheet

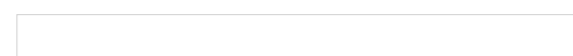

White SH3671



Museum

Features:

- 100% cotton fibre and lignen free
- Colour remains consistent throughout
- FATG Level 1

Archival Per
 1500µ 1020 x 815mm (40" x 32") Sheet



Bright White SH202



Soft White SH204



Antique White SH206

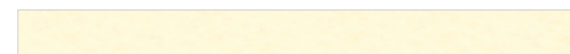

Almond SH208

Museum Barrier Per
 750µ 1020 x 815mm (40" x 32") Sheet



White SHMUBA

ColourMount
 SLATER HARRISON

Over 100 shades of ColourMount

Across our extensive stock range, ColourMount boards are ideal for hand and computerised cutters. Manufactured in the UK to exceed the Fine Art Trade Guild standards.

Conservation White Core · White Core · Black Core · Archival · Museum

Daler Rowney



Wessex Pictures stock the Daler Rowney white core mountboards. A wide range of colours available in a variety of textures and Ingres surfaces to finish off every type of art. Manufactured in the UK. All of the following Daler boards are available in single sheets.

DALER ROWNEY White Core Plus

Features:

- FATG Mountboard Level 3
- Conservation grade core made from alpha cellulose fibres
- Lignin-free and alkaline sized
- pH neutral
- Buffered with calcium carbonate to minimise pollutant effects

White Core Plus

1400µ 1200 x 815mm (47¼" x 32") Per Sheet

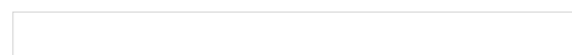

Bright White 302/128/017

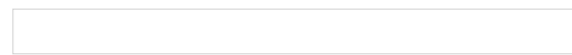

Tint 1 302/128/101



Ice White 302/128/091



Cumulus Cloud 302/128/404



Super White 302/128/062



Snow White 302/128/054

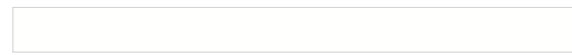

Snow White Texture 302/128/697

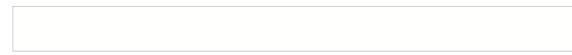

Polar White Ingres 302/128/200



Jasmine Texture 302/128/623



Lily White 302/128/003



Tint 3 Texture 302/128/103



Soft White Murano 303/065/035

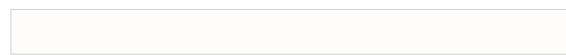

Soft White Ingres 302/128/267



Silver Birch 302/128/078

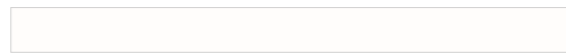

Cotton White Ingres 302/128/286



Tint 4 Ingres 302/128/104



Tint 5 302/128/105



Alpine White Texture 302/128/602



Antique White 302/128/069

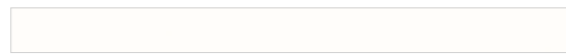

Antique White Texture 302/128/694



Milkwood Ingres 302/128/285

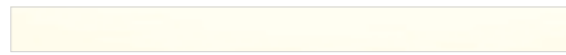

Daler Cream 302/128/020

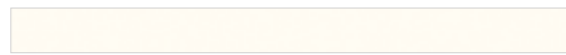

Tint 7 302/128/107

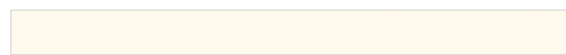

Tint 10 302/128/110



Papyrus Texture 302/128/655

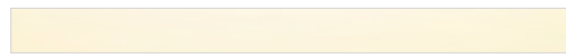

Ivory 302/128/030



Pale Ivory 302/128/070



Pale Ivory Texture 302/128/696

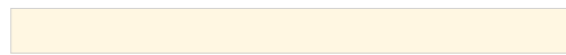

Antique Ivory Texture 302/128/601



Orchid Texture 302/128/638



Linen Flannel 302/128/357

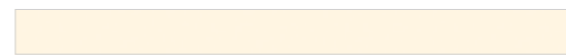

Champagne 302/128/011

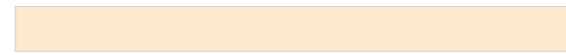

Cream Caramel Ingres 302/128/215

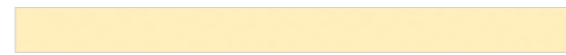

Deep Cream 302/128/019



Sand Ingres 302/128/299



Maize 302/128/092

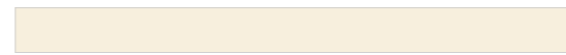

Light Parchment Texture 302/128/695



Parchment 302/128/045

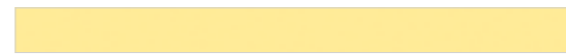

Primrose 302/128/024



Sahara 302/128/087



Terracotta 302/128/085



Dawn Pink 302/128/018



Sunset Pink 302/128/059



Poppy Red 302/128/723



Pillar Box Red 302/128/066



Scarlet 302/128/048



Crimson 302/128/016



Plum 302/128/067



Maroon 302/128/031

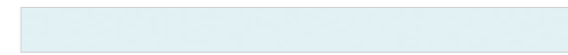

Delft Blue 302/128/074



Horizon Blue 302/128/028



Pompadour 302/128/041



Cobalt Murano 303/065/011



Hussar Blue 302/128/029



Saxe Blue 302/128/047



Oxford Blue Ingres 302/128/224



Twilight Blue 302/128/082



Damson 302/128/008



Aubergine Murano 303/065/002



Willow Green 302/128/068



Catkin 302/128/013



Soft Green 302/128/055



Emerald Murano 303/065/018



Avocado 302/128/002



Russian Green 302/128/043



Holly Green 302/128/027



Bottle Green 302/128/006



Stone 302/128/056

White Core Plus

1400µ 1200 x 815mm (47¼" x 32") Per Sheet



Fellstone Texture 302/128/606



Sandstone 302/128/046



Coffee 302/128/014



Sepia 302/128/050



Seal 302/128/049



Chocolate Murano 303/065/028



Silver Grey 302/128/052



Misty Grey 302/128/036



Dove Grey 302/128/022



Ash Grey 302/128/001

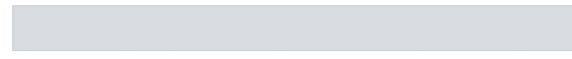

Dawn Grey 302/128/073



Mid Grey 302/128/034



Wedgwood 302/128/083



Stone Grey 302/128/737



Green Grey 302/128/026



Dark Grey 302/128/072



Midnight Murano 303/065/034



Charcoal Black 302/128/012



Poster Black 302/128/042



Deep Black 302/128/010



Gold Metallic 302/128/032



Silver Metallic 302/128/033

White Core Plus Extra Thick

2600µ 1200 x 815mm (47¼" x 32") Per Sheet



Polar White Ingres 302/128/800



Snow White 302/128/854



Antique White 302/128/869



Pale Ivory 302/128/870

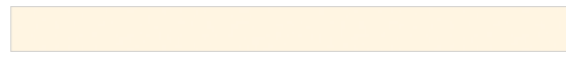

Champagne 302/128/811

White Core Plus Jumbo

1400µ 1525 x 1016mm (60" x 40") Per Sheet



Tint 1 302/128/701



Tint 3 Texture 302/128/703



Snow White 302/128/754



Snow White Texture 302/128/797

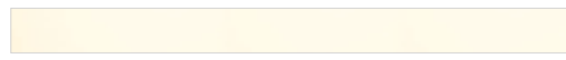

Antique White 302/128/769



Cotton White Ingres 302/128/786



Ice White 302/128/791



Poster Black 302/128/742



Daler-Rowney is a founder member of the Fine Art Trade Guild

+ White Core Plus

- Soft natural white core made from alpha cellulose fibres.
- Each board is lignen-free, alkaline sized, acid free and calcium carbonate buffered for enhanced durability and longevity.
- A clean and crisp bevel cut, the white colour remains white over time.
- FATG Certified.
- Made in England.

Daler Mountboards™

High quality UK manufactured mountboards.

Daler-Rowney mountboards are manufactured in the UK produced using wood pulp from managed forest estates in Europe.

These estates harvest and replant trees specifically for paper production and annually plant more trees than are felled.

All boards meet the stringent specifications of the Fine Art Trade Guild and a bespoke service allows custom sized boards to be made with any combination of core and cover paper.

Wessex Low Cost



A competitively priced range of mountboards available in standard, and white core.

White Core

Features:

- FATG Mountboard Level 4
- White core
- pH neutral
- Minimum 5 sheets per colour
- Quantity discounts available

Low Cost White Core			Per
1300µ	1200 x 815mm	(47¼" x 32")	5 Sheets

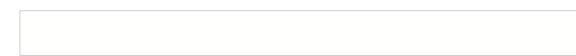

White WCM600



Bright White WCM662

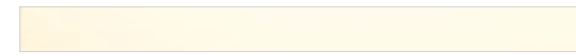

Antique White WCM601



Textured Polar White WCM602



Cotton White WCM686



Text Antique White WCM694



Textured White WCM697

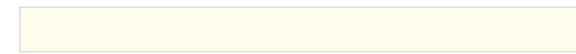

Pale Ivory WCM699

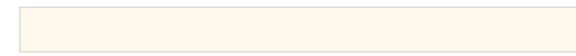

Champagne WCM611



Mid Green WCM655



Dark Green WCM643



Red WCM648



Dark Blue WCM666



Black WCM610

Cream Core

Features:

- FATG Mountboard Level 4
- Cream core
- pH neutral
- Minimum 10 sheets per colour
- Quantity discounts available

Low Cost Cream Core			Per
1400µ	1120 x 815mm	(44" x 32")	10 Sheets

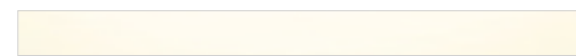

White WM500

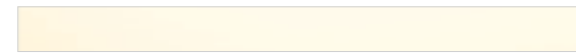

Antique White WM501



Pale Ivory WM599

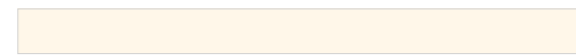

Ecru WM514



Black WM510



One Stop Shopping

the Wessex way for all your framing needs



- Board Products
- Display Products
- Dry Mounting
- Hardware
- Miscellaneous
- Mountboard
- Regular Glass
- Specialist Glass
- Specialist Plastic Glazing
- Tools and Equipment

wessexpictures.com

JUMBO



MOUNTBOARD CUTTING SERVICE

Wessex Pictures offer cut mounts up to 2440 x 1220mm with the new Valiani Maximus 250 mount cutter.

HOW IT WORKS:

Choose your ideal mount from our range see pages 119 - 121.

Order by email: sales@wessexpictures.com and include the following details:

- Overall size
- Orientation
- Aperture size(s)
- Border sizes
- Quantity

Wessex Fine Art will cut your mount, and Wessex Pictures will deliver directly to you on your usual delivery day.



sales@wessexpictures.com
www.wessexpictures.com



EXCELLENT PERFORMANCE & EXTREME PRECISION MOUNT CUTTING MACHINE:

VALIANI MAXIMUS 250



APPLICATIONS

- Mountboards for picture framing
- Multiple openings
- Spacers / Foamboard strips
- V-groove
- Shadow box
- Stacked mats
- Decorations & French lines
- Letters & text
- Memorabilia
- Debossed design elements
- Archival & conservation boxes

XXL MEGA JUMBO CRESCENT BEST RANGE

2440 x 1220mm

RagMat Museum Solids:

- 100% premium cotton board
- FATG Mountboard Level 1
- Solid colour
- Buffered with calcium carbonate to an alkaline reserve of 2 – 5%
- 100% lignin and spot free
- pH 7.5 – 9.5

1500µ 2440 x 1220mm (96" x 48") Per Sheet

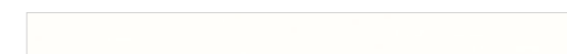

White CM2273

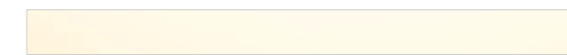

Antique White CM2279



Black CM2275

Extra Thick:

3000µ 2440 x 1220mm (96" x 48") Per Sheet

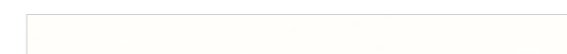

White CM22273

XL MEGA JUMBO CRESCENT BEST RANGE

1830 x 1220mm

Recommended uses for RagMat Museum Solids:

- Large pieces
- FATG Mountboard Level 1
- Valuable photographs and works of original art
- Fine art prints
- Rare and antique documents

1500µ 1830 x 1220mm (72" x 48") Per Sheet

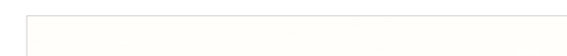

White CM2263

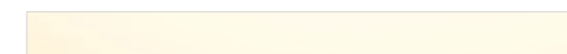

Antique White CM2269

Extra Thick:

3000µ 1830 x 1220mm (72" x 48") Per Sheet



White CM22263

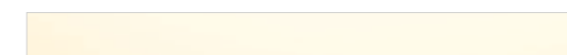

Antique White CM22269

XXL MEGA JUMBO CRESCENT BETTER RANGE

2440 x 1220mm

Crescent Conservation:

- 100% alpha cellulose
- FATG Level 2
- 100% lignin-free
- pH 8 – 8.5
- Perfect for limited editions, conservation level framing, fine art prints & photographs

Can be cut either Natural or White side up, please state your preferred when ordering:

2500µ 2440 x 1220mm (96" x 48") Per Sheet



Natural and White CMANW2596

**Crescent Good
White Core Jumbo**

1400µ 1520 x 1020mm (60" x 40") Per Sheet



Very White SRM8918

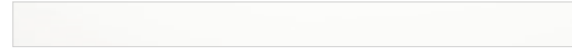

Arctic White SRM83297



Script White Vergé SRM81464

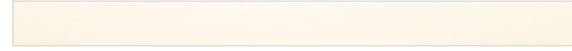

Palm Beach White SRM8987



Antique White SRM83293

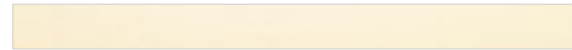

Spice Ivory SRM81028



Newport Blue SRM8977



Williamsburg Green SRM8988



Sierra Olive SRM83414



Bar Harbor Gray SRM8976



Cardiff SRM83536



Dark Gray SRM8924



Raven Black SRM8989



Smooth Black SRM8921

Crescent Better Conservation Jumbo

1500µ 1600 x 1200mm (63" x 47¼") Per Sheet

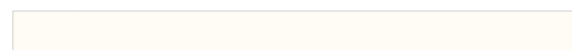

Natural CMAN1563

Crescent Better Conservation Jumbo Duo

1500µ 1620 x 1220mm (63¾" x 48") Per Sheet



Natural and White CMANW1563

**Crescent Better
Conservation Extra Thick Jumbo Duo**

2500µ 1620 x 1220mm (63¾" x 48") Per Sheet



Natural and White CMANW2563

**Crescent Best
RagMat Museum Solids Jumbo**

1500µ 1520 x 1020mm (60" x 40") Per Sheet



Winter White CM81188



White CM2262



Sand Dollar CM81126



Soft White CM81112



Antique White CM2260



Cream CM2261



Inverness CM81121

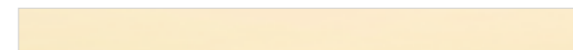

Almond CM81114



Antique Gray CM81106

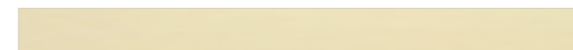

Antique Tan CM81104

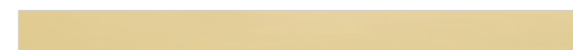

Desert Sand CM81105



Black CM81115

**Crescent Best
RagMat Museum Solids Extra Thick Jumbo**

3000µ 1520 x 1020mm (60" x 40") Per Sheet

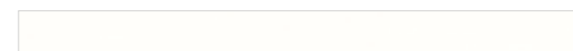

White CM2268



Winter White CM821188



Soft White CM821112

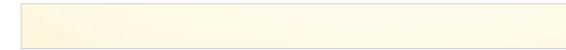

Antique White CM82239



Black CM821115

Larson Juhl Whitecore Jumbo

1400µ 1630 x 1120mm (64" x 44") Per Sheet

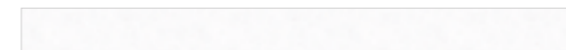

Snow White AM89001

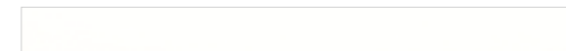

Arctic White AM89223



Photo White AM89278



Damascus Green AM89018



Black AM89011

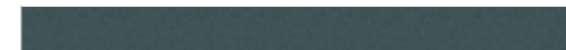

Silurian Blue AM89014

Larson Juhl Whitecore Jumbo

1400µ 1630 x 1020mm (64" x 40") Per Sheet

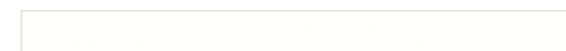

Bright White AM88977

Larson Juhl Conservation Jumbo

1400µ 1630 x 1120mm (64" x 44") Per Sheet

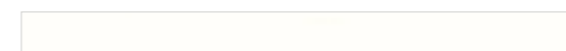

Glacier AM89698



Hayseed AM89065



Minuet AM89627



Cream AM89213



Vanilla AM89701

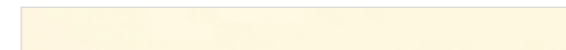

Pale Ivory AM89674



Ivory AM89043

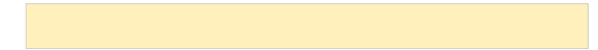

China White AM89002

Larson Juhl Blackcore Jumbo

1400µ 1630 x 1120mm (64" x 44") Per Sheet



Black AM97011

Larson Juhl Solidcore Jumbo

1500µ 1630 x 1120mm (64" x 44") Per Sheet

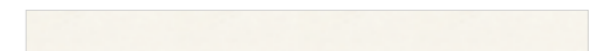

White AM9401



Off White AM9403



Cream AM9402

**Slater Harrison ColourMount
Conservation White Core Jumbo**

1400µ 1525 x 1020mm (60" x 40") Per Sheet

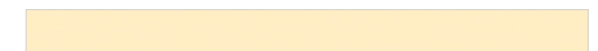

Pearl SHJ7300

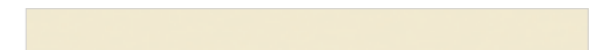

Ivory SHJ7301

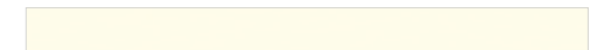

Beige SHJ7310



White SHJ7371

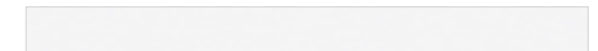

Soft White SHJ7375



Chalk White SHJ73001

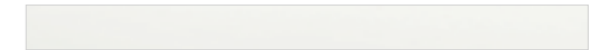

Haystack SHJ73965



Iced White SHJ73973



Antique White SHJ73975



Off White SHJ73981



JUMBO MOUNT-BOARD

CONTACT YOUR NEAREST BRANCH FOR MORE INFO

- Ashford 01233 637104
- Bournemouth 01590 681681
- Dereham 01362 690002
- Leamington Spa 01926 421984
- London 01372 377738
- Oldham 01616 812959

sales@wessexpictures.com
www.wessexpictures.com

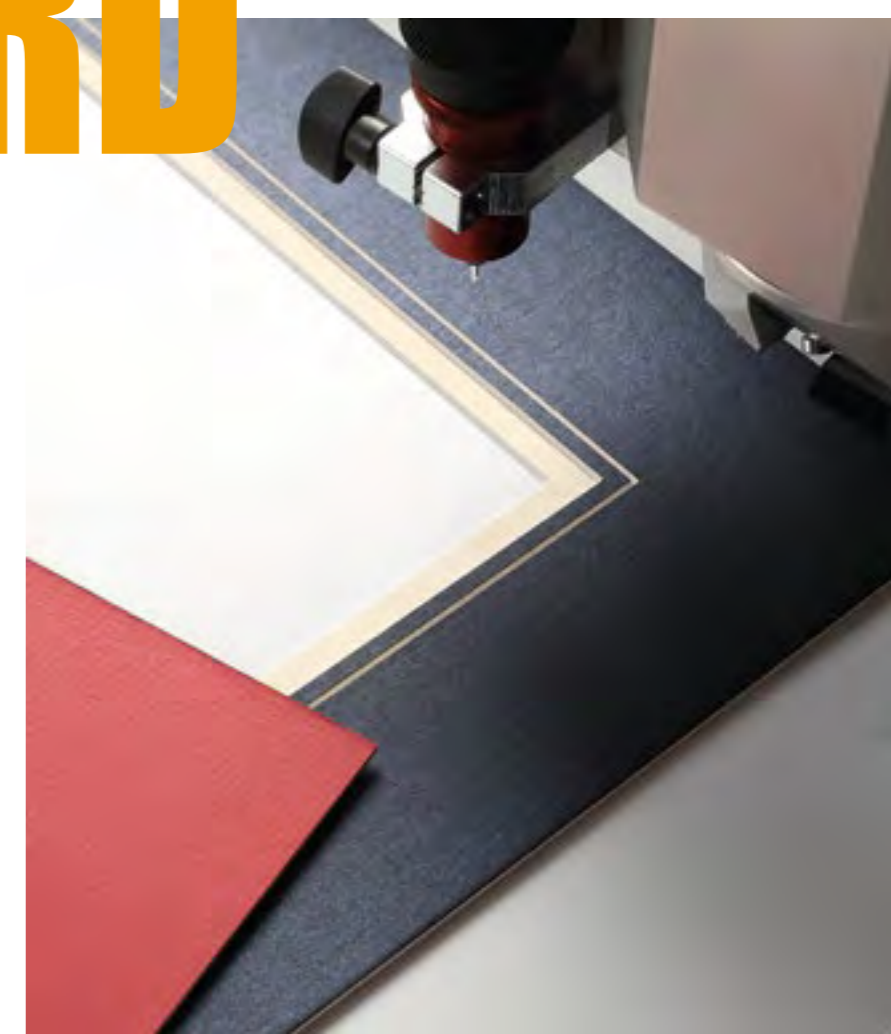

**Slater Harrison ColourMount
 Conservation White Core Jumbo Thick**
 2000µ 1525 x 1020mm (60" x 40") Per Sheet

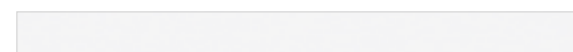

Soft White SHJU2375



Iced White SHJU2973



Antique White SHJU2975



Off White SHJU2981

**Slater Harrison ColourMount
 White Core Jumbo**
 1400µ 1525 x 1020mm (60" x 40") Per Sheet



Seal Brown SHJ7315



Portland SHJ7321



Charcoal SHJ7325



Bottle Green SHJ7332



Midnight SHJ7339



Oxford Blue SHJ7343



Old Gold SHJ7364



White SHJ7371



Simply White SHJ7391



Black SHJ7372



Platinum SHJCM19

**Slater Harrison ColourMount
 White Core Jumbo Thick**
 2000µ 1525 x 1020mm (60" x 40") Per Sheet

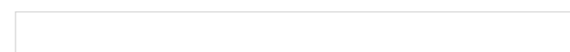

White SHJU2371



Black SHJU2372

**Slater Harrison ColourMount
 Black Core Jumbo**
 1250µ 1525 x 1020mm (60" x 40") Per Sheet



Black SHJBC472

**Daler Rowney
 White Core Plus Jumbo**
 1400µ 1525 x 1016mm (60" x 40") Per Sheet

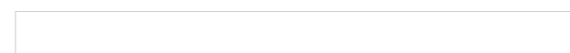

Tint 1 302/128/701



Tint 3 Texture 302/128/703

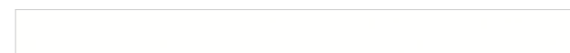

Snow White 302/128/754

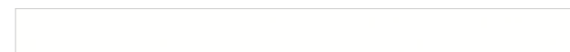

Snow White Texture 302/128/797

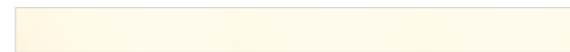

Antique White 302/128/769



Cotton White Ingres 302/128/786



Ice White 302/128/791



Poster Black 302/128/742

Board Products



From backing, fluted and foam core to self-adhesive and display, we offer a comprehensive range of board products suitable for all types of framing and dry mounting.

Corri-Cor®

Corri-Cor® offers outstanding quality with a gently bowed construction to hold artwork in place

- 8 grades to choose from
- High levels of protection
- Lightweight, dependably rigid and almost dust free
- Buffered with calcium carbonate, remaining pH neutral for 300 years
- Most grades are suitable for FATG conservation framing

Corri1

Corrugated core. Kraft finish on both sides.

Corri3

Water resistant coating on back. Double corrugated core. Kraft liners on both sides.

CorriCon

100% alpha cellulose liners. Double kraft core. No optical brighteners. Suitable for FATG conservation framing.

CorriConWR

Water resistant coating on back. Double corrugated core. Kraft liners on both sides. Suitable for FATG conservation framing.

Corri4

Kraft faced on the back. No optical brighteners. 100% virgin fibre throughout. Water resistant coating. Conforms to ISO 9706 standard. Suitable for FATG conservation framing.

CorriArc

100% alpha cellulose throughout. No optical brighteners. Suitable for FATG conservation framing.

CorriArcWR

Water resistant coating on back. 100% alpha cellulose throughout. No optical brighteners. Suitable for FATG conservation framing.

CorriPlusPB

Made from heavy weight archival papers. 100% virgin fibre. Designed to protect valuable items. Suitable for FATG conservation framing.



Specifications

		Per
CORRI1	2.35mm 1220 x 915mm (48" x 36")	Sheet
CORRI3	2.6mm 1220 x 915mm (48" x 36")	Sheet
CORRICON	2.6mm 1220 x 915mm (48" x 36")	Sheet
CORRICONWR	2.6mm 1220 x 915mm (48" x 36")	Sheet
CORRI4	2.5mm 1220 x 915mm (48" x 36")	Sheet
CORRARC	2.6mm 1220 x 915mm (48" x 36")	Sheet
CORRIARCWR	2.6mm 1220 x 915mm (48" x 36")	Sheet
CORRIPLUSPB	4.5mm 1600 x 1200mm (63"x47¼")	Sheet

Art-Bak®

The original fluted backing board which is the modern equivalent to MDF

- 3 grades to choose from
- Manufactured in the UK from 100% recyclable material
- Twin wall technology for a stronger, more rigid board
- Buffered with calcium carbonate, remaining pH neutral for 300 years
- Has a unique curve, keeping artwork flatter

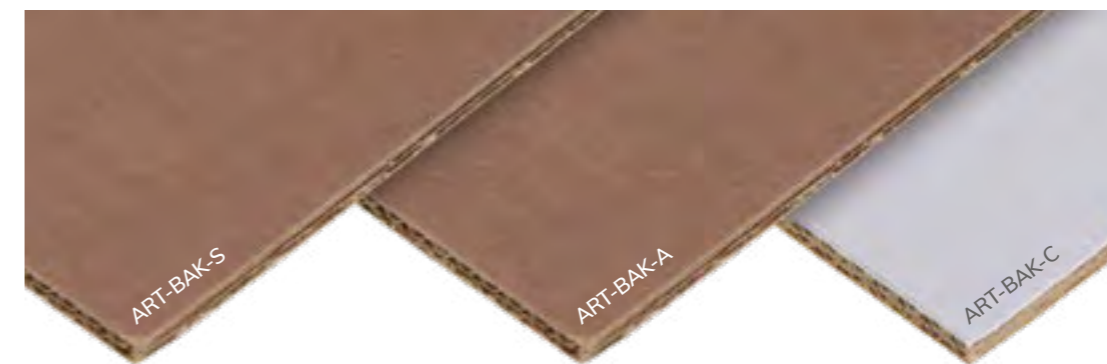

Standard Grade (Art-Bak-S)

The original corrugated framing board, triple walled for extra rigidity. A versatile board with traditional appearance.

Aqua Grade (Art-Bak-A)

Similar to the standard board with the addition of a water resistant membrane to one side.

Conservation Grade (Art-Bak-C)

Similar to the aqua board with the addition of a conservation grade white barrier board which faces the artwork. Conforms to ISO9706 for archival use.

Specifications

		Per
ART-BAK-S	3.2mm 1220 x 915mm (48" x 36")	Sheet
ART-BAK-A	3.3mm 1220 x 915mm (48" x 36")	Sheet
ART-BAK-C	2.9mm 1220 x 915mm (48" x 36")	Sheet

MDF - Medium Density Fibre Board

We stock a huge range of MDF board from 2mm to 12mm thickness in sheet and cut sizes. We can also custom cut to any bespoke size. MDF is a great mounting board, and when handled correctly it offers good dimensional stability. Thicker MDF is ideal for block mounting.



				Per
MDF2	2mm	1220 x 915mm	(4' x 3')	Sheet
MDF5	2.5mm	1220 x 915mm	(4' x 3')	Sheet
MDF3	2.5mm	1525 x 1220mm	(5' x 4')	Sheet
MDF7	2.5mm	1830 x 1220mm	(6' x 4')	Sheet
MDF13	2.5mm	2500 x 1240mm	(8'2" x 4')	Sheet
MDF9	3mm	1220 x 915mm	(4' x 3')	Sheet
MDF14	3mm	1830 x 1220mm	(6' x 4')	Sheet
MDF15	3mm	2440 x 1220mm	(8' x 4')	Sheet

Extra Thick

				Per
MDF11	6mm	2440 x 1220mm	(8' x 4')	Sheet
MDF12	12mm	2440 x 1220mm	(8' x 4')	Sheet

Cut to Size

				Per
CH02/7x5	2.5mm	178 x 127mm	(7" x 5")	50
CH03/8x6	2.5mm	203 x 152mm	(8" x 6")	50
CH04/9x7	2.5mm	229 x 178mm	(9" x 7")	50
CH05/10x8	2.5mm	254 x 203mm	(10" x 8")	50
CH06/A4	2.5mm	297 x 210mm	(A4)	25
CH07/12x10	2.5mm	305 x 254mm	(12" x 10")	25
CH08/14x11	2.5mm	356 x 279mm	(14" x 11")	25
CH10/16x12	2.5mm	406 x 305mm	(16" x 12")	25
CH11/20x16	2.5mm	508 x 406mm	(20" x 16")	20
CH12/24x20	2.5mm	610 x 508mm	(24" x 20")	20
CH13/30x20	2.5mm	762 x 508mm	(30" x 20")	10
CH14/28x24	2.5mm	711 x 610mm	(28" x 24")	10
CH15/A3	2.5mm	420 x 297mm	(A3)	25

Foam Centred Board

White on both sides and pH neutral. It is light weight, very rigid and easy to cut. It comes in a variety of sizes and thicknesses. Recommended for cold mounting procedures under 40°C.

			Pack Qty	Per
FO1	3mm	1016 x 762mm	5 or 25	Sheet
FO11	3mm	1016 x 1524mm	5 or 25	Sheet
FO2	5mm	1016 x 762mm	5 or 25	Sheet
FO4	10mm	1016 x 762mm	5 or 25	Sheet
FO9	10mm	3050 x 1524mm	5 or 25	Sheet



Foam Centred Board - Premium

Light, dimensionally stable and very rigid. Faced with high quality clay coated liners, for a good adhesive key. The dense core is suitable for processing in a hot vacuum press.

			Pack Qty	Per
FO3	5mm	1524 x 1016mm	5 or 25	Sheet
FO12	5mm	2440 x 1220mm	5 or 25	Sheet
FO5	10mm	2440 x 1220mm	5 or 25	Sheet



Foam Centred Board - Acid Free

Lignin free face papers with a pH value between 7.5 - 9.5. The papers are buffered with a 3 - 5% alkaline reserve. Ideal for conservation mounting applications and processing in a hot vacuum press.

			Pack Qty	Per
FO6	5mm	1020 x 810mm	5 or 25	Sheet
FO7	5mm	1520 x 1020mm	5 or 25	Sheet
FO15	5mm	2440 x 1220mm	5 or 25	Sheet



Foam Centred Self Adhesive Standard Board

A more cost effective option to the Perfect Mount board. It is not repositionable and the initial grab is quite high. Like the Perfect Mount, it is ideal for posters, photography and inkjet media but more care needs to be taken when first laying down. **Not to be used for valuable artwork, and we strongly recommend testing on a small area before use.**

			Pack Qty	Per
FO13	5mm	1016 x 762mm	5 or 25	Sheet
FO14	5mm	1524 x 1016mm	5 or 25	Sheet

Foam Centred Self Adhesive Crescent Perfect Mount

This board has an acid free adhesive that works at room temperature. The initial tack of the adhesive is quite low, allowing for repositioning, but firmer pressure will create a permanent bond. This board is ideal for posters, photographs and inkjet media. **Not to be used for valuable artwork, and we strongly recommend testing on a small area before use.**

			Pack Qty	Per
FO8	5mm	1020 x 813mm	5 or 25	Sheet



Foam Centred Board - All Black

This foam centred board has black face papers and a solid black core. It is often used for graphic panels that are going to remain unframed and gives a neat and minimalist finish to your artwork. This board is suitable for processing in a hot vacuum press.

			Pack Qty	Per
FO10	5mm	1016 x 810mm	5 or 25	Sheet

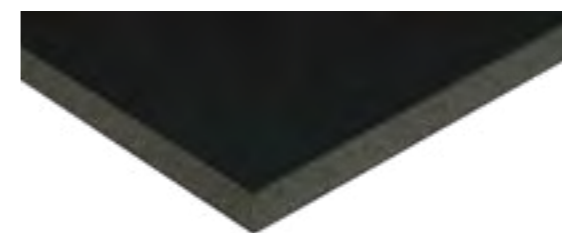

Foam Centred Board - Kraft Lined

Perfect if you want your mount board to double up as the backing board for a framed piece. The front of the board is white and the rear face is coated with a brown kraft facing paper - looks similar to an MDF frame back on the finished product.

			Pack Qty	Per
KLF02	5mm	1400 x 1000mm	5 or 25	Sheet



Nubord®

Nubord® is thick grey board which has good quality kraft paper on both sides. It is an excellent rigid alternative to MDF and is easy to cut.

				Per
NUBORD1	2.3mm	1220 x 915mm		Sheet
NUBORD2	1.79mm	1220 x 915mm		Sheet
NUBORD3	3.0mm	1500 x 1000mm		Sheet



Nubord® Con

Nubord® Con has all the benefits of regular Nubord® with the added benefit of a conservation grade white barrier paper on one side.

				Per
NUBORDCON	2.1mm	1220 x 915mm		Sheet



Kraft Lined Board

This board is ideal to double up as a mounting board and a frame back. The face is coated with white acid free facing paper made of 100% alpha cellulose. The centre of the board is either a tough grey card (KLB2) which is quite rigid or a softer cream pulp board (KLB3) which is easier to cut. The back is coated with brown kraft paper. Looks very similar to an MDF frame back.

			Per
KLB2	2.5mm	1220 x 800mm	Sheet
KLB3	2.5mm	1220 x 800mm	Sheet



Grey Board

At 2000µ thick, grey board is rigid enough for most jobs and is a great price. It has a smooth surface, is easy to cut and pH neutral.

			Per
ESK2	2mm	1120 x 815mm (44" x 32")	Sheet



Ryno Board®

An extruded high density polystyrene foam board with double-thick, clay coated, bright white liners that add to its rigidity and structural performance. Good resistance to crushing, warping and denting that remains stable after mounting or laminating. Excellent for signage and graphic applications.

			Per
F021	5mm	2440 x 1220mm	Sheet



Box Board

Perfect if you're looking to stiffen a piece of artwork without mounting it to a 'rigid' board. At just 600µ thick, box board is tough enough to reinforce your work without adding too much thickness or weight. It has a clay coated surface which is great for adhesion, is super smooth and pH neutral.

			Per
BB1	600µ	1120 x 815mm (44" x 32")	Sheet



Display Board

At 2000µ thick, white display board has a dense grey core and doesn't readily absorb moisture. The clay coated, high white board liners act as a good key for adhesives. White display board is pH neutral and porous - an added advantage when using a vacuum press

			Per
DISB2	2mm	1219 x 900mm (48" x 35½")	Sheet
DISB3	2mm	1550 x 1060mm (61" x 41¾")	Sheet



Whitecore Backing Board

1.1mm thick, FATG Conservation level suitable for mounting, backing and dry mounting.

			Per
AM8950	1.1mm	1120 x 815mm (44" x 32")	Sheet



Britback Backing Board

A lightweight, easy to cut fluted board used to back prints and pre-cut mounts or as a backing board for small pictures. Coated on one side with a white paper liner.

			Per
BRITBACK	1.4mm	1220 x 915mm (48" x 36")	Sheet



Hardboard

The traditional choice for backing pictures. Due to its longer fibre structure, hardboard tends to stay flatter for longer. It has been gradually replaced by lighter and easier to cut MDF.

			Per
HB43	3mm	1220 x 915mm (48" x 36")	Sheet

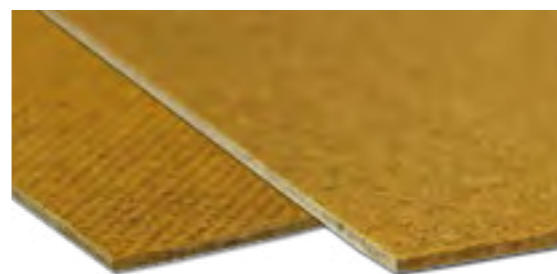

Pulpboard

Pulpboard is suitable for backing mounted prints and packing out pictures.

			Per
PB1	1.2mm	1143 x 815mm (45" x 32")	Sheet



Barrier Board

Wessex Barrier Board is only 600µ thick and made from 100% alpha cellulose. It's acid and lignin free, buffered with calcium carbonate complying to ISO 9706. Manufactured to FATG Conservation standards.

			Per
WBB1	0.6mm	1120 x 815mm (44" x 32")	Sheet



Self-Adhesive Board

For best results, it's recommended to store artwork with self-adhesive board to acclimatise. If unsure, it's advisable to test before using. Self-adhesive boards are not recommended for valuable works or irreplaceable items.

Wessex Pictures cannot be held responsible for any subsequent damage.



Crescent Perfect Mount Self-Adhesive Board

Featuring an acid-free adhesive and buffered, pH neutral surfaces, perfect mount self-adhesive boards allow for easy positioning until firm pressure activates a permanent bond. Bonds permanently after 24 hours.

					Per
CMPSX	1350µ	1020 x 810mm	(40" x 32")	Sheet	

High Tack Self-Adhesive Board

Featuring an acrylic adhesive, high tack board gives a permanent bond. It has a neutral pH of 7.0 and is an economic, easy way of mounting pictures.

					Per
ESA1	1400µ	1200 x 800mm	(47½" x 32½")	Sheet	
JSA1	2500µ	1520 x 1020mm	(60" x 40")	Sheet	

Daler Rowney Self-Adhesive Board

With a cream core made from virgin wood pulp, Daler Rowney self-adhesive board uses no waste or secondary fibres. The core is alkaline sized, pH neutral and manufactured in the UK.

The adhesive surface is repositionable, perfect for lighter weight papers.

					Pack Qty	Per
302/140/000	1400µ	1120 x 815mm	(44" x 32")	5	Sheet	

Daler Rowney Extra Tak Self-Adhesive Board

With an extra strong permanent adhesive surface, this board is suitable for heavier weight papers and some photographic papers.

					Pack Qty	Per
302/214/000	1400µ	1120 x 815mm	(44" x 32")	5	Sheet	

Larson Juhl Permanent Mount Board

Specifically designed for textiles and photographs, it's extra tack is ideally suited to heavier duty items.

					Pack Qty	Per
999-000-350	1500µ	1120 x 815mm	(44" x 32")	5	Sheet	
999-000-351	2300µ	1120 x 815mm	(44" x 32")	5	Sheet	

Larson Juhl Heat Activated Mount Board

Designed for use in a heat press, a permanent bond is achieved in seconds - without any mess.

					Pack Qty	Per
999-000-450	1250µ	1120 x 815mm	(44" x 32")	5	Sheet	

Slater Harrison Self-Adhesive Board

The adhesive used on the ColourMount boards is repositionable. Available in three different cores (cream, grey and white) as well as a 2-in-1 Kraft faced board that eliminates the need for another backing board.

					Pack Qty	Per
SHSACC1500	1500µ	1125 x 815mm	Cream	5	Sheet	
SHSAGC1500	1500µ	1125 x 815mm	Grey	5	Sheet	
SHSAWC1200	1200µ	1200 x 800mm	White	5	Sheet	
SHKRAFT21	3000µ	1200 x 1000mm	Kraft	5	Sheet	

The newly refurbished Leamington Spa branch



is now ready to bring you the complete **ONE STOP SHOPPING SERVICE**



01926 421984 www.wessexpictures.com

6 Berrington Road, Sydenham Industrial Estate, Royal Leamington Spa, CV31 1NB

Hardware



When it comes to the back of a picture frame, we stock a huge range of products. We have all the fittings you are ever likely to use in your gallery or workshop.

Picture Frame Fittings

Security Screws

Available for both wood and extruded aluminium frames. On wood frames the adapter plates are fixed to the reverse of the frame moulding. Small frames only need two fixings but three fixings are recommended for larger frames.

Rawlplugs are included and these are fixed to the wall to match the adapter plate positions. Screws are inserted into the rawlplugs with the heads matching the slot positions. The frame is pushed to the wall and the heads of the screws are turned 90 degrees with the special spanner. The frame can only be removed from the wall with the spanner.

The aluminium fixings work in exactly the same way but the heads locate in the back of the extruded aluminium section before turning to lock them in place. Commonly used for displaying artwork in public places, such as hotel rooms and restaurants.

		Per
999-000-009	Aluminium Security Screws (x3)	Pack
999-000-010	Wood Security Screws (x3)	Pack
SPAN1	Security Screw Spanner	Each

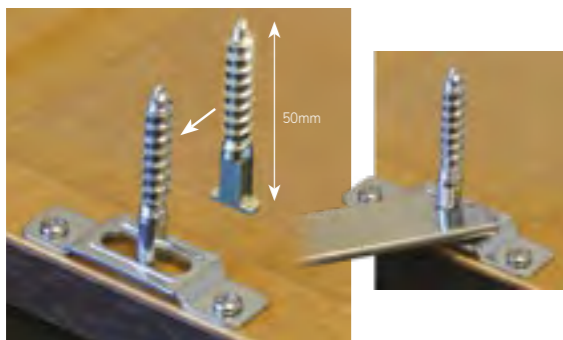

Bifurcated and Capped Rivets

A neat and secure way to attach D rings to MDF frame backs. Rivets are pushed through, then spread by hammering the rivet against a solid surface.

		Per
BR30	5/16" (8mm) x 14 Nickel Bifurcated Rivets	1000
BR31	3/8" (9mm) x 14 Nickel Bifurcated Rivets	1000
BR32	3/8" (9mm) x 11 Nickel Bifurcated Rivets	1000
BR34	3/8" (8mm) Capped Rivets Nickel	1000



Brass Butt Hinges

Decorative fixings for hinging small frames together so that they can be stood on a dressing table or mantelpiece. Can also be used on small frames where the image needs to be changed on a regular basis.

		Per
BH911	3/4" (20mm) Brass Butt Hinges	200

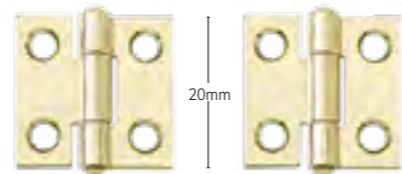

Canvas Offsets

A quick, simple and effective way of fixing canvases in to frames where the rebate isn't deep enough to fully accommodate it. Can be used from underneath if you want to float a canvas in a modern 'L' frame.

		Per
COS06	6mm Canvas Offsets	200
COS06/20	6mm Canvas Offsets	20
COS09	9mm Canvas Offsets	200
COS09/20	9mm Canvas Offsets	20
COS12	12mm Canvas Offsets	200
COS12/20	12mm Canvas Offsets	20
COS18	18mm Canvas Offsets	200
COS18/20	18mm Canvas Offsets	20



Springlock Security Fixings

Frames in public places often need to be hung in a manner that makes them un-removable without the right tool. For reasons of health and safety or to discourage theft, securely fixing frames to walls is a good idea. The bridge section is fitted to the frame back, lined up with screws in the wall and then the lock is pushed into place with thumb pressure. To release the frame from the wall a special tool (SPRINGH1) is required. It is slid behind the frame and releases the locking section when pulled back.

		Per
SPRING1	Springlock Security Fixing	1 pair
SPRING5	Springlock Security Fixings	5 pairs
SPRING10	Springlock Security Fixings	10 pairs
SPRING100	Springlock Security Fixings	100 pairs
SPRINGSLOT1	Springlock Slot Fixing	Each
SPRINGSLOT10	Springlock Slot Fixing	10
SPRINGSLOT100	Springlock Slot Fixing	100
SPRINGH1	Springlock Release Tool	Each

METHOD 1 - Side to Side

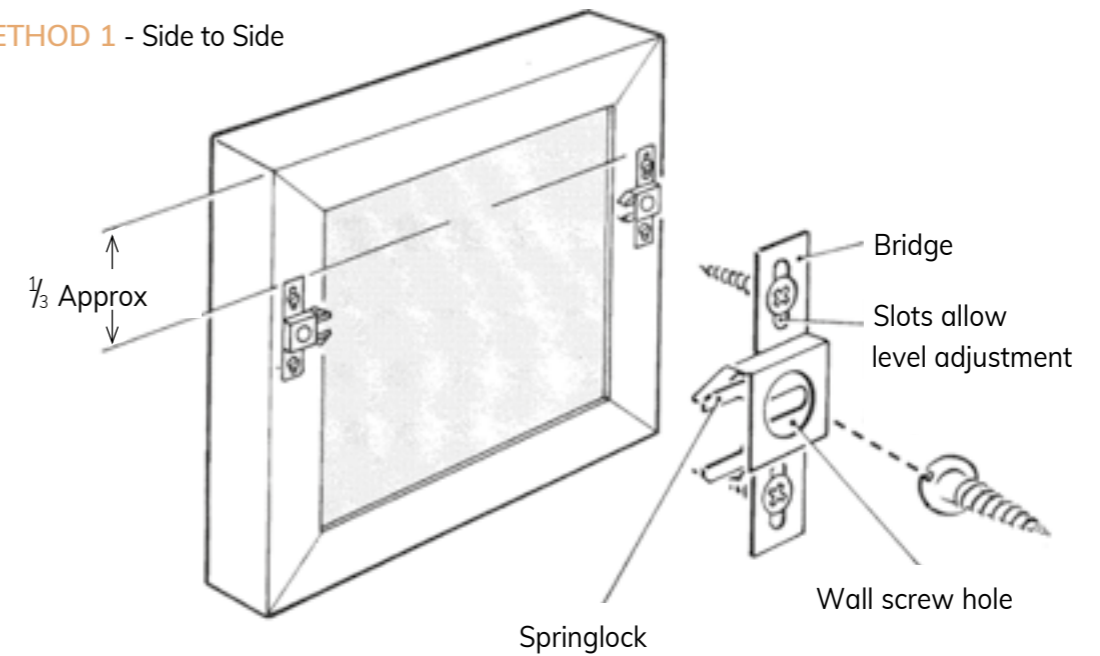

METHOD 2 - Hanging Plate

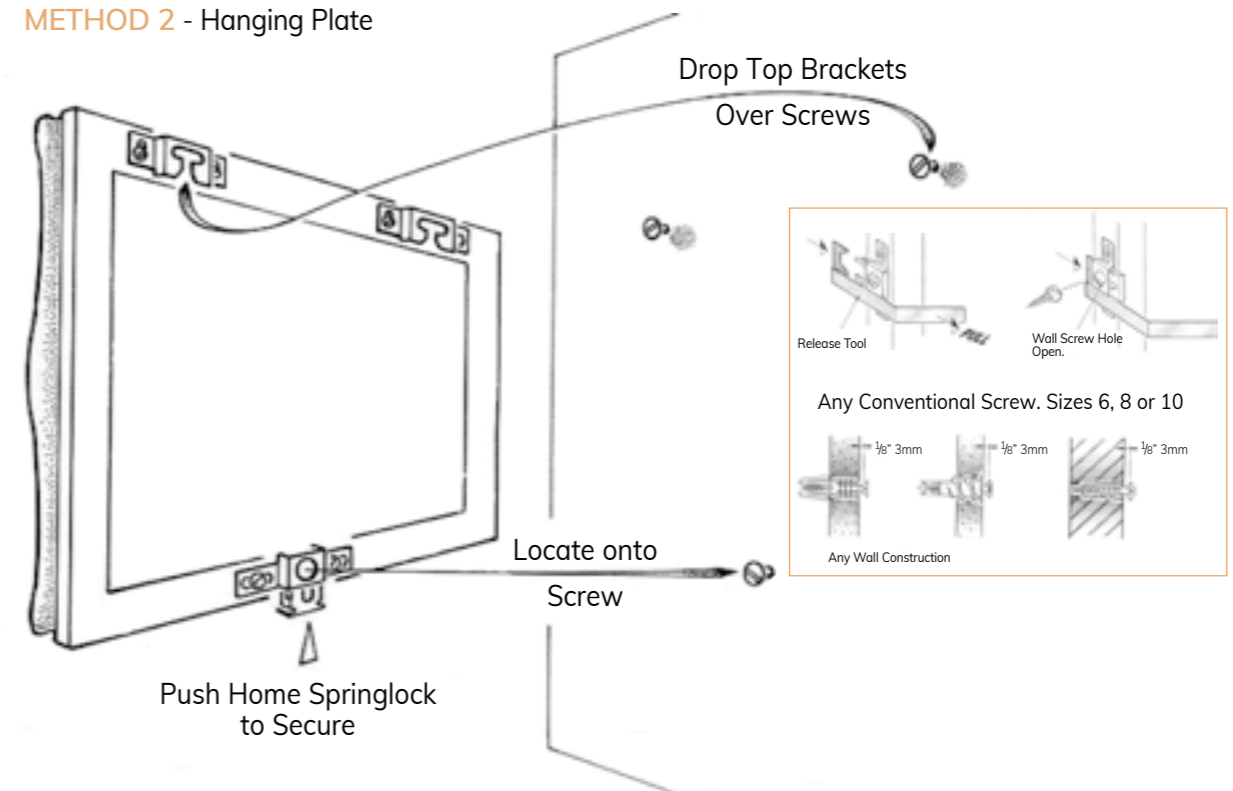

Clip Over Hangers

The hanger is clipped over the top of the backing board before it is inserted into the frame. The edge has a saw tooth profile to stop the frame moving around on the wall.

	Per
COH1447 Clip Over Hangers	1000

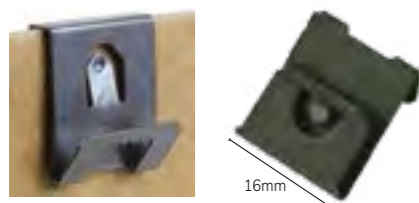

D Rings

D rings come in a variety of finishes and sizes and can be attached to mouldings or backing boards. They can be used as a hanger in themselves, but are mainly used as fixings for cord, wire or chain.

	Per
DR750 Single D Rings Nickel	100
DR751 Single D Rings Nickel	1000
DR752 Single D Rings Brassed	100
DR753 Single D Rings Brassed	1000
DR754 Small Single D Rings Nickel	100
DR755 Small Single D Rings Nickel	1000
DR756 Single Standard D Rings Nickel	100
DR757 Single Standard D Rings Nickel	1000
DR760 Double D Rings Nickel	100
DR761 Double D Rings Brassed	100

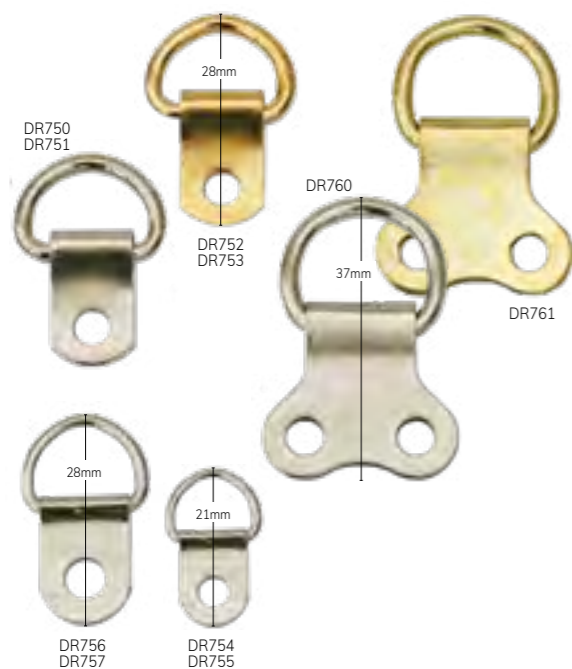

Disc Plate Hangers

The disc plate hanger is very secure and doesn't cause any damage when removed. Simply wet the hanger, fix it to the back of the plate and leave it to dry completely. Soak the plate in warm water to remove the hanger.

	Per
DPH571 1 1/4" (30mm) Disc Plate Hangers	50
DPH572 2" (50mm) Disc Plate Hangers	50
DPH573 3" (75mm) Disc Plate Hangers	50
DPH574 4" (100mm) Disc Plate Hangers	50
DPH575 5 1/2" (140mm) Disc Plate Hangers	50



Other diameter sizes available:
50mm, 75mm, 100mm, 140mm

Emo Clips

Used for making "bespoke" sized clip frames. The clips hold an MDF back / your artwork / glass or plastic front together securely. The finished effect is of a "frameless frame" and is often used for posters or point of sale materials. Make sure you take the sharp edge off the glass when using emo-clips (see hand seaming tool or diamond pad page 67).

	Per
EC2156 2156 Emo Clips Small	100
EC2157 2157 Emo Clips Hanging	100
EC2166 2166 Emo Clips Large	100



Escutcheon Pins

In brass or "brassed" finishes, these pins are used for fixing various hangers into framed work with a traditional clean looking finish. Triangle hangers, saw tooth hangers, turnbuttons and smaller glass plates can all be fixed with these pins.

	Per
EP130 19g Brassed Escutcheon Pins	1/2 kilo
EP131 19g Brass Escutcheon Pins	1/2 kilo
EP132 16g Brass Escutcheon Pins	1/2 kilo



Ferrules

These are used to neaten up the appearance of picture hanging wire. Slide 2 appropriately sized ferrules on to your frame wire, prior to securing it to your D rings. After you have secured the wire, slide each ferrule over the wire twist and crimp securely with pliers.

	Per
F71 No 1 Brass Ferrules (for No. 1 Brass Wire)	500
F72 No 2 Brass Ferrules (for No. 2 Brass Wire)	500
F73 No 3 Brass Ferrules (for No. 3 Brass Wire)	500



Fixing Plates - Bendable

Made from a thin brass plate. Ideal for fixing inner frames, canvases, etc. Easily fixed using small screws or pins.

	Per
BFP1 Bendable Fixing Plates	100

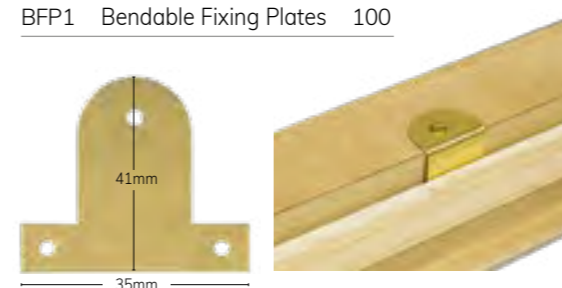

Firescreen Handles and Feet

Framed images or needlework can be used as decorative fire screens by adding these traditional polished brass feet and handles to a sturdy wooden frame. Simply screw them into place.

	Per
FF850 5 1/2" (134mm) Brass Firescreen Feet	Pair
FH860 4 3/4" (123mm) Brass Firescreen Handle	Each



Fletcher Triangle Points

Triangle points are used for securing glass into frames with a minimal amount of the point remaining visible. They can be used in conjunction with the Fletcher Pushmate tool.

	Per
TP08311 11mm Fletcher Triangle Points	2700



Frame Bumpers - Foam

These foam self-adhesive squares (12mm) prevent framed or block mounted work from 'leaning' when hung on a wall. They also create a small air gap at the back of the work, to allow air to circulate and inhibit dampness build up.

	Per
FBUMP 12mm Foam Frame Bumpers	576



Frame Bumpers - Felt

Used in exactly the same way as the foam frame bumpers but made from a self-adhesive white felt, 15mm diameter circles.

	Per
FBUMP1 White Felt Bumpers 1.3mm thick	400
FBUMP2 White Felt Bumpers 2.9mm thick	1000
FBUMP3 White Felt Bumpers 4.6mm thick	1000



Gummed Cloth Hangers

Made from sturdy cloth. Wet the gummed side and press firmly against the surface you want to stick it to. For a stronger bond you can coat them with a contact adhesive instead. Ideal for hanging posters.

	Per
GH25 1 1/4" (29mm) Gummed Cloth Hangers	1000



Toly Hard Wall Hooks

The original Toly hard wall hooks. These hooks are made for walls where standard picture hook pins struggle for a secure hold. Simply press the hook against the wall and use a hammer to push the pins into the wall. Made for walls of brick, breeze block or concrete. They work best with hanging cord, try not to use hanging wire. Medium and large hooks come with centre pins for added strength on softer walls.

	Per
HWH14 Small Toly Hard Wall Hooks	100
HWH24 Medium Toly Hard Wall Hooks	100
HWH34 Large Toly Hard Wall Hooks	100



Glass Plates - Standard

Used for screwing picture frames securely onto a wall. Two screws go into the back of the frame and one goes into the wall. Available in brass or brass plated finish. Often used where health and safety is a concern, stopping the frame falling off the wall.

		Per
GP2001	1" (25mm) Brass Glass Plates	100
GP2001/20	1" (25mm) Brass Glass Plates	20
GP2002	1 1/4" (32mm) Brass Glass Plates	100
GP2002/20	1 1/4" (32mm) Brass Glass Plates	20
GP2003	1 1/2" (38mm) Brass Glass Plates	100
GP2003/20	1 1/2" (38mm) Brass Glass Plates	20
GP2315/1	3/4" (20mm) Brass Glass Plates	200
GP2315/1/20	3/4" (20mm) Brass Glass Plates	20
GP2315/2	1" (25mm) Brass Glass Plates	200
GP2315/2/20	1" (25mm) Brass Glass Plates	20
GP2315/3	1 1/4" (32mm) Brass Glass Plates	200
GP2315/3/20	1 1/4" (32mm) Brass Glass Plates	20
GP2315/4	1 1/2" (38mm) Brass Glass Plates	100
GP2315/4/20	1 1/2" (38mm) Brass Glass Plates	20
GP2315/5	1 3/4" (44mm) Brass Glass Plates	100
GP2315/5/20	1 3/4" (44mm) Brass Glass Plates	20
GP2315/6	2" (51mm) Brass Glass Plates	100
GP2315/6/20	2" (51mm) Brass Glass Plates	20

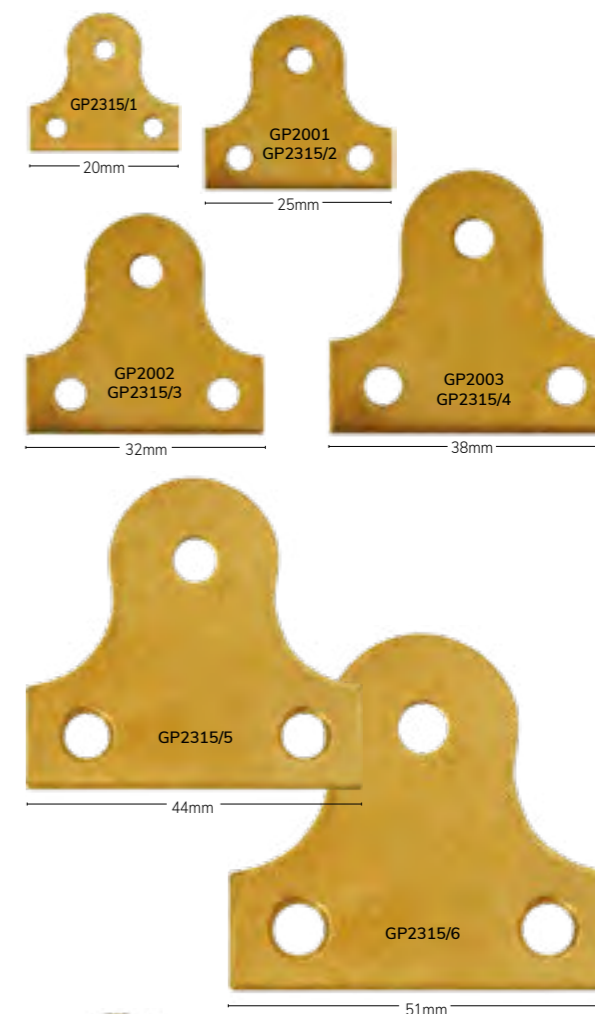

Glass Plates - Slotted

These allow the frame to be taken down without the removal of the fixing screw in the wall. They are normally used on the top of the frame.

		Per
GP2319/1	1" (25mm) Brass Slotted Glass Plate	100
GP2319/1/20	1" (25mm) Brass Slotted Glass Plate	20
GP2319/2	1 1/4" (32mm) Brass Slotted Glass Plate	100
GP2319/2/20	1 1/4" (32mm) Brass Slotted Glass Plate	20
GP2319/3	1 1/2" (38mm) Brass Slotted Glass Plate	100
GP2319/3/20	1 1/2" (38mm) Brass Slotted Glass Plate	20

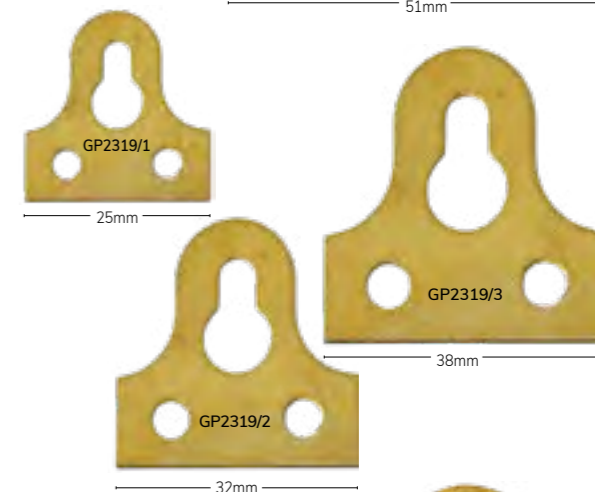

Glass Plates - Reverse Slotted

Used in conjunction with slotted glass plates but underneath the frame to give more stability.

		Per
GP2321/1	1" (25mm) Brass Slotted Glass Plate	100
GP2321/1/20	1" (25mm) Brass Slotted Glass Plate	20
GP2321/2	1 1/4" (32mm) Brass Slotted Glass Plate	100
GP2321/2/20	1 1/4" (32mm) Brass Slotted Glass Plate	20
GP2321/3	1 1/2" (38mm) Brass Slotted Glass Plate	100
GP2321/3/20	1 1/2" (38mm) Brass Slotted Glass Plate	20

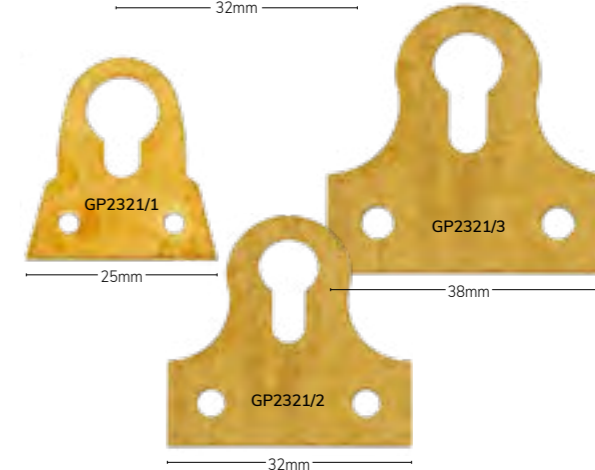

Descriptions:
 Brass plated = Brass plated steel • Brass = Solid brass

Moulding Hooks - Narrow

The broader end is hung over a picture rail and the narrow end is used to attach the picture. Use oval chain or picture chain to create a vintage look.

		Per
NMH120	Narrow Moulding Hooks Brass	100
NMH120/10	Narrow Moulding Hooks Brass	10
NMH121	Narrow Moulding Hooks Chrome	100
NMH121/10	Narrow Moulding Hooks Chrome	10
NMH122	Narrow Moulding Hooks Bronze	100
NMH122/10	Narrow Moulding Hooks Bronze	10

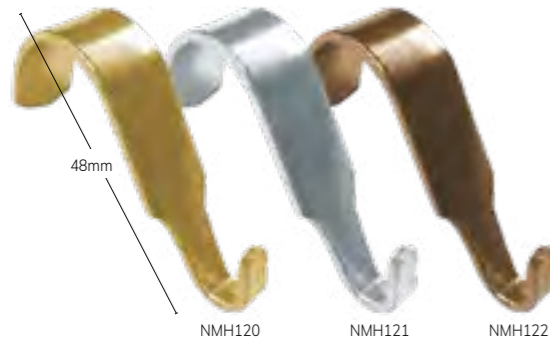

Moulding Hooks - Wide

		Per
WMH0168	Wide Moulding Hooks Brass	50
WMH0168/10	Wide Moulding Hooks Brass	10
WMH0169	Wide Moulding Hooks Chrome	50
WMH0169/10	Wide Moulding Hooks Chrome	10
WMH0170	Wide Moulding Hooks Bronze	100
WMH0170/10	Wide Moulding Hooks Bronze	10

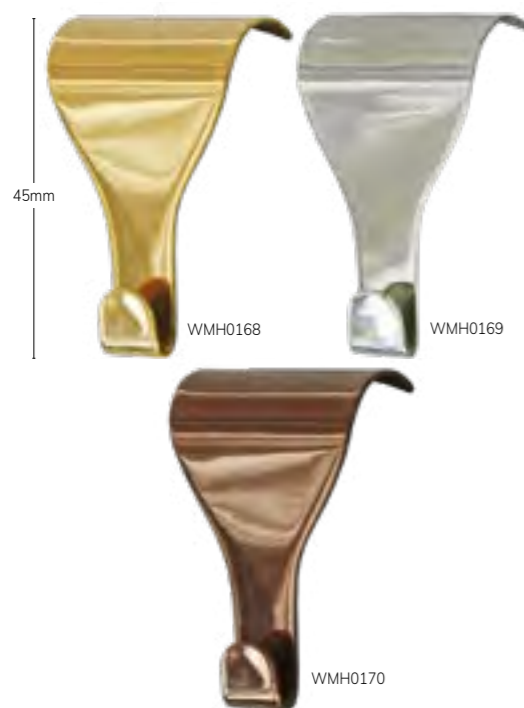

Brass Chains

Used as an alternative to cord or wire on traditionally styled frames. Chains are often sized to show above the top of the frame on a decorative plate style hook. The effect is very distinctive. Available in oval or tear drop shape.

		Per
OC72	3/8" (10mm) Brass Oval Chain	10m
OC74	1/2" (12mm) Brass Oval Chain	10m
OC76	5/8" (16mm) Brass Oval Chain	10m
OC78	3/4" (19mm) Brass Oval Chain	10m
OC80	1" (25mm) Brass Oval Chain	10m



		Per
PC260	1 1/16" (18mm) Brass Picture Chain	10m
PC262	1" (25mm) Brass Picture Chain	10m
PC263	1 3/16" (30mm) Brass Picture Chain	10m
PC264	1 5/16" (33mm) Brass Picture Chain	10m
PC265	1 5/16" (33mm) Heavy Brass Picture Chain	10m



Picture Hangers

An alternative to D rings that offer a very flush finish. They are designed to work with 2mm backing boards. Slide the hangers on either side of the back board before inserting into the frame. Once in, the frame cord can be attached through the exposed loop holes and friction holds them in place.

		Per
PH2MM	Universal Picture Hangers	100



Picture Pins

These pins are used in conjunction with brass "x" wall hooks, which do come with pins included, but extra pins never go to waste.

		Per
PP600	Brassed Picture Pins	1000
PP700	Brass Headed Picture Pins	200



Plate Hooks

A very sturdy wall hanging solution for heavy work. They can be used to mate with D rings or to suspend corded, wired or chained frames.

		Per
PH296	2 1/2" (55mm) Brass Plate Hooks	50
PH296/10	2 1/2" (55mm) Brass Plate Hooks	10
PH297	4" (100mm) Black Plate Hooks	50
PH297/10	4" (100mm) Black Plate Hooks	10
PH298	3" (75mm) Black Plate Hooks	50
PH298/10	3" (75mm) Black Plate Hooks	10
PH299	2" (50mm) Black Plate Hooks	50
PH299/10	2" (50mm) Black Plate Hooks	10



Panel Pins

Panel pins are used for a variety of jobs. If you do not have an underpinner, side pinning frames in the traditional way still joins mouldings very securely.

		Per
PP80	1/2" x 20 gauge Panel Pins	1/2 kilo
PP81	3/4" x 19 gauge Panel Pins	1/2 kilo
PP82	1" x 18 gauge Panel Pins	1/2 kilo
PP84	1 1/4" x 16 gauge Panel Pins	1/2 kilo
PP85	1 1/2" x 15 gauge Panel Pins	1/2 kilo
PP86	2" x 14 gauge Panel Pins	1/2 kilo
PP87	2 1/2" x 12 gauge Panel Pins	1/2 kilo

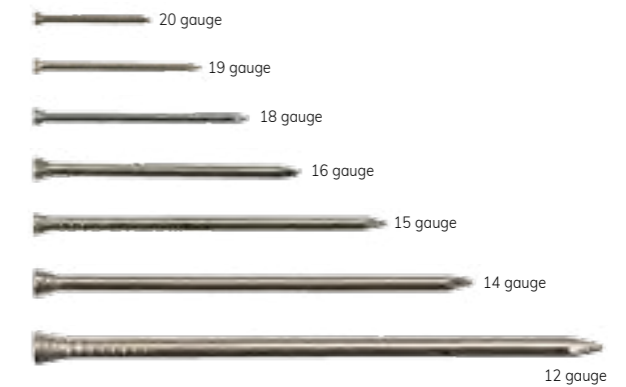

Plate Rings

Plate rings can be used in conjunction with plate hooks, for hanging heavy work very securely. They can also be used as an alternative to D rings, again where weight is a major concern. The three fixing holes offer a very sturdy fixing method.

		Per
PR394	3/4" (20mm) Brass Plate Rings	50
PR396	1" (25mm) Brass Plate Rings	50
PR398	1 1/4" (32 mm) Brass Plate Rings	50



Brass Wall Hooks - Genuine 'X' Hooks

Available in a variety of sizes for lightweight to very heavy work. The pin holes are set at an angle, so that the pins (which are included) embed in a downward direction into the wall for extra strength. The two larger size hooks also have heart shaped holes to use as screw holes for added strength.

		Per
PWH231	No 1 Brass 'X' Wall Hooks	100
PWH232	No 2 Brass 'X' Wall Hooks	100
PWH233	No 3 Brass 'X' Wall Hooks	100
PWH234	No 4 Brass 'X' Wall Hooks	50

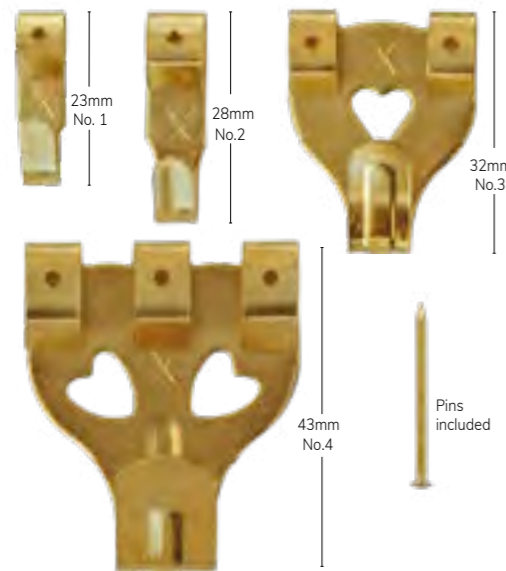

Brass Rings and Clips

The clip is passed through a backing board, such as MDF and then the tails are opened and spread flat against the inner side of the board to secure the ring section in place. It is suggested that tape be placed over the tails to prevent any marking to the artwork.

		Per
RAC330	3/8" (9mm) Brass Rings & Clips	1000
RAC331	1/2" (12mm) Brass Rings & Clips	1000
RAC332	1/2" (12mm) Brass Rings & Long Clips	1000
RAC333	5/8" (16mm) Brass Rings & Long Clips	1000



Picture Wire - Brass

Made from braids of brass strands, around a steel wire. Brass picture wire offers a traditional looking finish to the back of frames. When using brass picture wire it should be used in conjunction with other brass fittings to avoid the wire corroding.

Suggested max weight	No. 3 Wire	18 Kilos
No. 1 Wire	6 Kilos	No. 3 1/2 Wire 24 Kilos
No. 2 Wire	11 Kilos	No. 3 3/4 Wire 29 Kilos

		Per
PWBG78	1 Brass Picture Wire 150 mtr	Reel
PWBG79	2 Brass Picture Wire 150 mtr	Reel
PWBG80	3 Brass Picture Wire 150 mtr	Reel
PWBG81	3 1/2 Brass Picture Wire 150 mtr	Reel
PWBG82	3 3/4 Brass Picture Wire 120 mtr	Reel



Plastic Coated Steel Wire

High quality wires laboratory tested for tensile strength. Always use a wire with a tensile strength at least double that of the weight of the picture (see below chart). Weights given are maximum picture weights. This wire has been specially tempered to be easy to bend, wrap and tie. Stainless steel will not corrode in salty or damp environments.

Suggested max weight	No. 2 Wire	8 kg / 17.6 lb	No. 4 Wire	14 kg / 30.8 lb
No. 3 Wire	10 kg / 22.0 lb	No. 5 Wire	19 kg / 41.8 lb	

		Per
PCSW2	Plastic Coated Steel Wire #2 (457m)	Reel
PCSW3	Plastic Coated Steel Wire #3 (343m)	Reel
PCSW4	Plastic Coated Steel Wire #4 (252m)	Reel
PCSW5	Plastic Coated Steel Wire #5 (152m)	Reel

Screw Eyes

Screw eyes come in a variety of sizes and finishes (zinc / brass / brassed). Simply screw into the back of your frame moulding and then attach wire or cord to complete your hanging system.

		Per
SE62	12 x 00 Brassed Screw Eyes	500
SE83	14 x 1 Brassed Screw Eyes	500
SE84	16 x 1 Brassed Screw Eyes	500
SE66	20 x 2 Brassed Screw Eyes	200
SE65	16 x 1 Zinc Screw Eyes	500
SE68	25 x 4 Zinc Screw Eyes	200
SE79	16 x 1 Solid Brass Screw Eyes	500
SE80	20 x 2 Solid Brass Screw Eyes	200
SE81	25 x 4 Solid Brass Screw Eyes	200



Repair Plates

For repairing old frames or strengthening joints on new frames. Three different styles, depending on where the repair needs more strength.

		Per
RP2922	1 3/8" (34mm) Brassed Repair Plates	20
RP2924	1 5/16" (33mm) Brass Repair Plates	20
RP2926	2 1/4" (55mm) Brassed Repair Plates	20

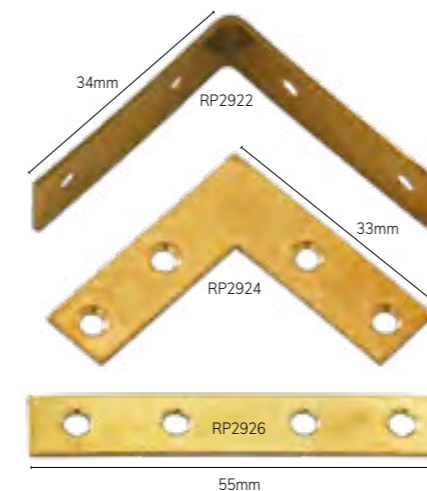

Screw Rings

Quite simply a screw eye with a ring through it. Offers an easier method of tying cord and looks neater from the side view. Screw rings work well as a method of securing chain too.

		Per
SR63	0 (Small) Brass Plated Screw Rings	200
SR64	1 Coppered Screw Rings	200
SR65	2 Medium Coppered Screw Rings	200
SR66	2L (Long) Coppered Screw Rings	200
SR67	3 Coppered Screw Rings	200
SR68	4 (Large) Coppered Screw Rings	200
SR69	5 Coppered Screw Rings	200
SR70	6 Coppered Screw Rings	200

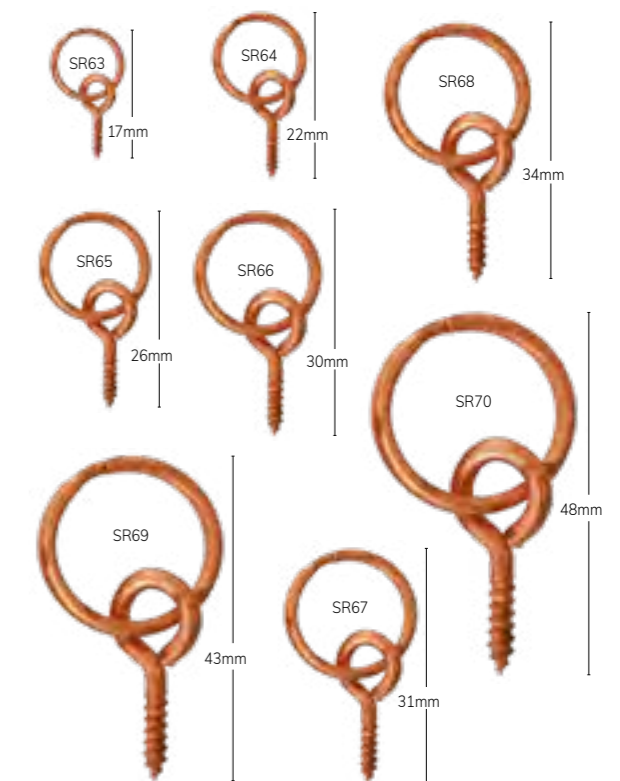

Strap Hangers

With three fixing holes, strap hangers are a popular solution for hanging heavy work. The fixing ring remains fairly flush to the moulding. Often used in conjunction with Wall Plates (see page 148).

		Per
SH77	2 5/8" (65mm) Zinc Strap Hangers	50
SH77/10	2 5/8" (65mm) Zinc Strap Hangers	10



Spring Clips

Spring clips are screwed onto the back face of mouldings to secure backing boards in place. A simple turn of the spring clips allows the back board to be removed, so that artwork can be changed quickly and neatly.

		Per
SC96	1" (25mm) Zinc Spring Clips	200
SC97	1 3/4" (45mm) Zinc Spring Clips	200

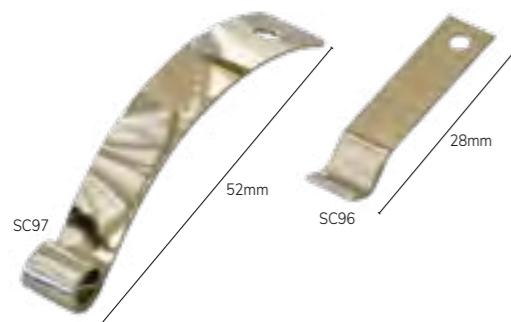

Strut Hinges

If you need to make strut backs for non-standard sized frames then this is the solution. The bars are attached to the frame back and the clips are fixed to your struts.

		Per
SH743	Zinc/Blued Strut Hinges	200 Sets
SHB743	Zinc Strut Hinge Bars	500
SHC743	Blued Strut Hinge Clips	500

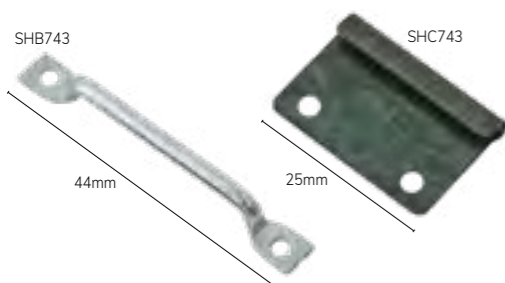

Saw Tooth Hangers

Commonly used on MDF block mounts, but can also be used on the top bar of most mouldings, as a fast and sturdy hanging system. The saw tooth edge faces down and stops the wall fixing from slipping to the left or right of the hanger.

		Per
STH50	Saw Tooth Hangers Brass	200

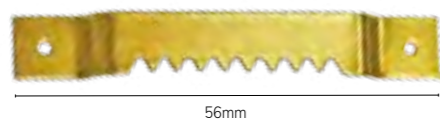

Split Rings

Split rings have a multitude of uses, but are often used in conjunction with screw eyes and picture chain, offering a very safe and secure method of fixing the two together.

		Per
SR94	1" (25mm) Steel Split Rings	300



Top Fixing Screw Rings

Sometimes referred to as "watch top hangers". This decorative hanger screws into the top of your frame, rather than the back, hanging the frame like a fob watch. It is commonly used in conjunction with brass plate hooks. Top fixing screw rings are also very useful for displaying frames that may be glazed on both sides, where other hanging systems would spoil the rear view of the frame.

		Per
TFSR64	5/8" (16mm) Top Fixing Screw Rings	50
TFSR65	1 1/16" (18mm) Top Fixing Screw Rings	50
TFSR66	1 3/4" (32mm) Top Fixing Screw Rings	50
TFSR67	1" (23mm) Top Fixing Screw Rings	50

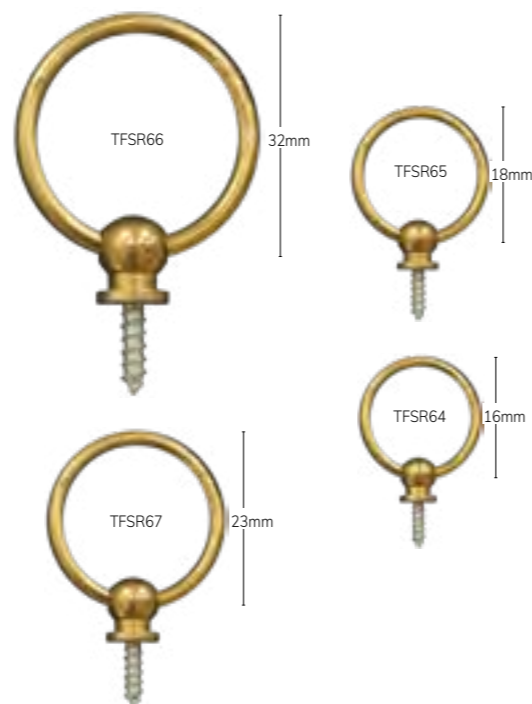

Tray Handles

Certain frame mouldings make excellent edges for lap trays. The addition of tray handles make trays look more attractive. Available in three distinctive styles, tray handles can be attached with either screws or escutcheon pins.

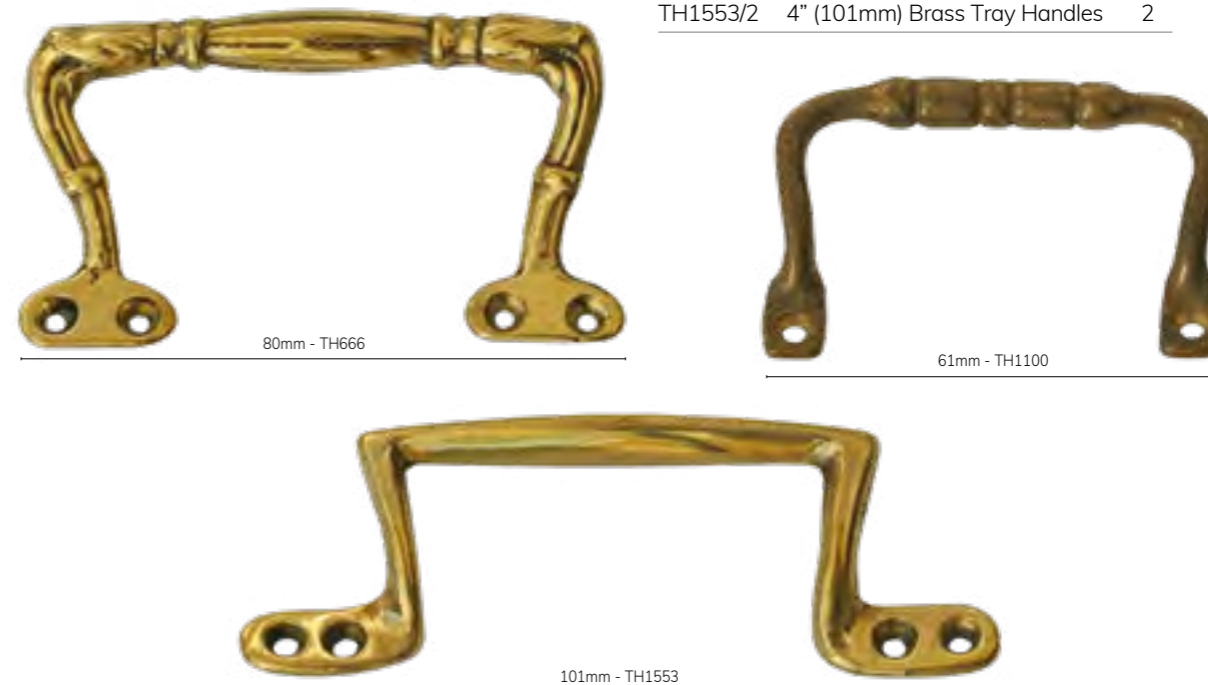

		Per
TH666	3 1/8" (80mm) Brass Tray Handles	10
TH666/2	3 1/8" (80mm) Brass Tray Handles	2
TH1100	2 1/2" (61mm) Brass Tray Handles	10
TH1100/2	2 1/2" (61mm) Brass Tray Handles	2
TH1553	4" (101mm) Brass Tray Handles	10
TH1553/2	4" (101mm) Brass Tray Handles	2

Triangle Hangers

Commonly used with MDF block mounts, as a fairly low profile hanging system that keeps the block close to the wall or sometimes on the top edge of a frame as a direct hanging system, without cord or wire.

		Per
TH45	1/2" (12mm) Brass Triangle Hangers	1000
TH46	5/8" (15mm) Brass Triangle Hangers	1000
TH47	3/4" (19mm) Brass Triangle Hangers	1000
TH48	1" (23mm) Brass Triangle Hangers	1000

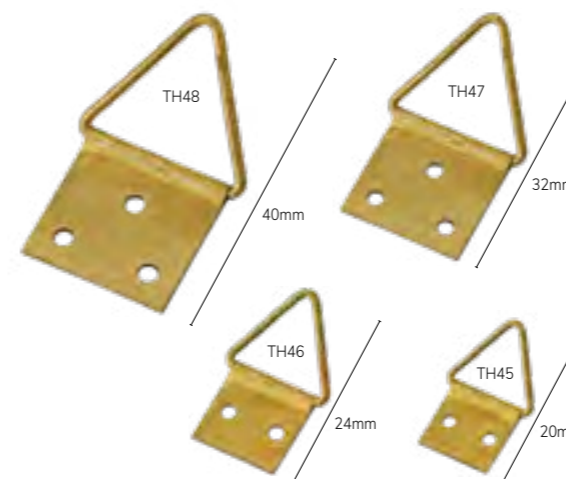

Turn Buttons

Available in a variety of sizes and shapes. Turn buttons are used to create traditional looking frame backs, where the back of the frame may need to be accessed at some point, such as when changing the artwork inside.

		Per
T360	1/2" (13mm) Brass Turnbuttons	400
T363	1 5/16" (24mm) Brass Turnbuttons	400
T365	3/4" (19mm) Brass Turnbuttons	400
T366	1" (25mm) Brass Turnbuttons	400



Wall Plates

Similar to strap hangers and can be used in conjunction with strap hangers (see page 145). The long plate, with 2 regular holes and a slotted hole for adjustment, is fixed to the wall for a very strong hanging method. Works well with cord, wire or chain.

		Per
WP67	Wall Plates	50
WP67/10	Wall Plates	10



'Z' Clips

A traditional way of holding stretched canvases in frames. Tap one end of each clip into the frame rebate, with several around each side for large canvases. Bend the clips back a little and slip in the canvas before finally pushing the clip over the canvas and tapping it firmly into place.

		Per
ZC95	1 1/4" (32mm) Coppered Z Clips	1000
ZC96	1 1/4" (32mm) Coppered Z Clips	100



D Rings - Single

		Per
BPSDR	Blister Pack Single D Rings	12 packs



Frame Plates - Small

		Per
BPSFP	Blister Pack Small Frame Plates	12 packs



D Rings - Double

		Per
BPDDR	Blister Pack Brass Double D Rings	12 packs



Hard Wall Hooks

		Per
BPHWH	Blister Pack Hard Wall Hooks	12 packs



Blister Packs

The addition of blister packs framing accessories increases value added sales in a retail environment. Rather than taking from your own stock, blister packed accessories in small quantities can be sold at higher prices as they have more perceived value. Hooks and stands for blister pack displays are available from point of sale and shop fitting suppliers.

Hooks

		Per
BP1SH	Blister Pack No.1 Small 'X' Hooks	12 packs
BP2MH	Blister Pack No.2 Medium 'X' Hook	12 packs
BP3DH	Blister Pack No.3 Double 'X' Hook	12 packs
BP4ELH	Blister Pack No.4 Ex.Large 'X' Hooks	12 packs



BP1SH



BP2MH



BP3DH



BP4ELH

Frame Plates - Large

		Per
BPLFP	Blister Pack Large Frame Plates	12 packs



J Hooks

		Per
BPJH	Blister Pack 'J' (Plate) Hooks	12 packs



Picture Cord

	Per
BPPC Blister Pack Hard Wall Hooks	12 packs



Picture Hanging Kit

	Per
BPPK Blister Pack X Picture Kit	12 packs



Picture Rail Hooks

	Per
BPPRHA Blister Pack Picture Rail Hooks - Antique	6 packs
BPPRHB Blister Pack Picture Rail Hooks - Brass	6 packs



Picture Wire

	Per
BPPW1 Blister Pack No.1 Picture Wire	12 packs
BPPW2 Blister Pack No.2 Picture Wire	12 packs
BPPW3 Blister Pack No.3 Picture Wire	12 packs



Pins

	Per
BPBHP Blister Pack Brass Headed Pins	12 packs



Poster Hangers

	Per
BPPHP Blister Pack Poster Hangers & Pins	12 packs



Saw Tooth Hangers

	Per
BPSTH Blister Pack Saw Tooth Hangers	12 packs



Screw Eyes

	Per
BPSE Blister Pack Screw Eyes	12 packs
Mix of Small, Medium & Large	



X Hooks

A similar concept to the blister packs. The cartons of branded X wall hooks, both brass and plastic hard wall, can be used to increase sales in a retail environment.

		Per
PXWH221	No. 1 Brass X Hooks	Carton
PXWH222	No. 2 Brass X Hooks	Carton
PXWH223	No. 3 Brass X Hooks	Carton
XHWH24	Hard Wall X Hooks	Carton



Steel Blades

General purpose steel blades have a multitude of uses. We offer a choice of thinner and thicker versions. The "backed" blades are regarded as sturdier and safer to work with in the hand.

		Per
BSM202	201/012 Steel Blades	100
BSM311	310/017 Steel Blades	100

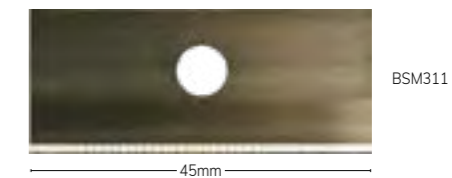
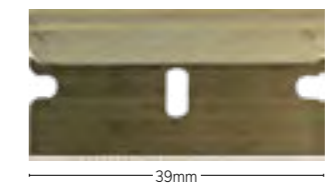

C&H Blades

Genuine replacement blades for C&H mount cutters, made to their strict specifications. 'SE' denotes that the blades are only sharpened on one edge.

	Per
CH1200SE 1200SE Mountcutter Blades	100



Stanley Knife Blades

The very popular STANLEY blades are used in a wide variety of hand craft knives and also older KEENCUT machines, such as the SYSTEM 4000. The SKB1991 works with KEENCUT ULTIMATS.

	Per
SKB1991 1 7/8" Stanley Knife Blades	100
SKB1991/10 1 7/8" Stanley Knife Blades	10
SKB1992 2 3/8" Stanley Knife Blades	100
SKB1992/10 2 3/8" Stanley Knife Blades	10

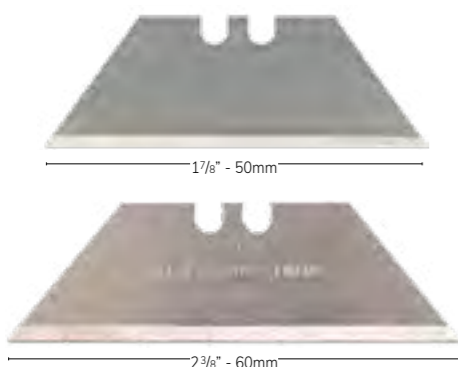

Swan Morton Handles

Many people in the graphics industry still prefer to use a scalpel to a craft knife and we offer a range from a top supplier. Swan Morton is a very long established and respected manufacturer of the highest quality surgical and craft handles and blades. We offer a choice of the two most popular handles used in the graphics and arts industries.

HSM3	Swan Morton No.3 Handles	Each
HSM7	Swan Morton No.7 Handles	Each



Swan Morton Blades

We offer a choice of the three most popular blades for our Swan Morton handles – Standard (10A) / Long (11) / Rolling (10). Additionally we offer two types of Swan Morton blades which are compatible with some older mount cutting machines, such as the KEENCUT RONDO and OVAL 6.

	Per
BSM10 10 Swan Morton Blades	100
BSM10A 10A Swan Morton Blades	100
BSM11 11 Swan Morton Blades	100
BSM02 02 Steel Blades	50
BSM03 03 Steel Blades	50

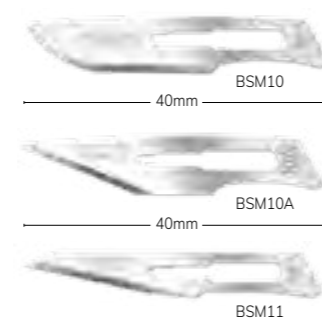

The 10, 10A & 11 blades fit the handles shown above

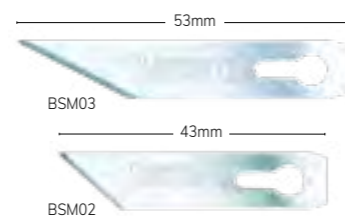

Snap Off Knives and Blades

These general purpose 'craft' knives are commonly used in print finishing. They use a retractable snap off blade system, which is held securely by a simple locking clamp. They are comfortable in the hand, pocket sized, feature a blade snapping clip and most importantly cut straight and evenly every time.

We offer three versions. The standard 9mm knife is for the most lightweight work.

The 18mm comes in a standard and heavy duty version and this is the cutter of choice for most mounting and laminating professionals. These knives are perfect for cutting all kinds of boards, from white display board and foam centred board to foamex and even thinner MDF panels.

Replacement blades are fast and easy to fit.

	Per
WS1 Snap Off Knife 18mm	Each
WS2 Snap Off Knife 9mm	Each
WS3 Heavy Duty Snap Off Knife 18mm	Each
WB1 18mm Snap Off Blades	10
WB2 9mm Snap Off Blades	10



Strut Backs

Ready made frame backs including a hinged strut. Suitable for standing frames in either landscape or portrait format. Made from smooth MDF with an extended strut to cater for even wide mouldings.

Quantity discounts for assorted sizes:

10% for 50+ • 15% for 100 • 20% for 200+

SBH02	MDF Strut Back 102 x 152mm (4" x 6")	Each
SBH04	MDF Strut Back 127 x 178mm (5" x 7")	Each
SBH05	MDF Strut Back 152 x 203mm (6" x 8")	Each
SBH06	MDF Strut Back 178 x 229mm (7" x 9")	Each
SBH07	MDF Strut Back 203 x 254mm (8" x 10")	Each
SBH08	MDF Strut Back 254 x 305mm (10" x 12")	Each
SBH10	MDF Strut Back 279 x 356mm (11" x 14")	Each
SBH11	MDF Strut Back 210 x 297mm (A4)	Each



Screws

Wessex offer a wide range of screws which are manufactured to the highest standards and suitable for all applications. Wessex do not supply Philips head screws, instead we offer slotted and the more durable Pozi head varieties.

Brass Counter Sunk

	Per
BCS03	1/4" x 2 Brass Counter Sunk Screws 200
BCS05	3/8" x 2 Brass Counter Sunk Screws 200
BCS06	3/8" x 3 Brass Counter Sunk Screws 200
BCS07	3/8" x 4 Brass Counter Sunk Screws 200
BCS08	1/2" x 2 Brass Counter Sunk Screws 200
BCS09	1/2" x 3 Brass Counter Sunk Screws 200
BCS10	1/2" x 4 Brass Counter Sunk Screws 200
BCS13	5/8" x 6 Brass Counter Sunk Screws 200

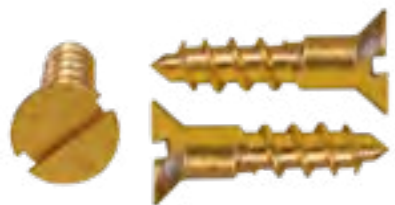

Brass Round Headed

	Per
BRH02	3/8" x 1 Brass Round Headed Screws 200
BRH03	3/8" x 2 Brass Round Headed Screws 200
BRH04	3/8" x 3 Brass Round Headed Screws 200
BRH05	3/8" x 4 Brass Round Headed Screws 200
BRH06	1/2" x 2 Brass Round Headed Screws 200
BRH07	1/2" x 3 Brass Round Headed Screws 200
BRH08	1/2" x 4 Brass Round Headed Screws 200

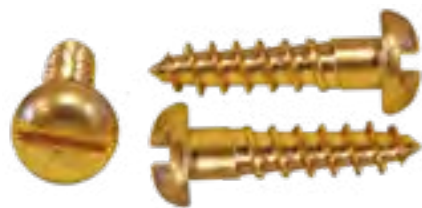

Steel Counter Sunk

	Per
SC03	1/4" x 2 Steel Counter Sunk Screws 200
SC05	3/8" x 2 Steel Counter Sunk Screws Zinc Plated 200
SC06	3/8" x 3 Steel Counter Sunk Screws Zinc Plated 200
SC07	3/8" x 4 Steel Counter Sunk Screws Zinc Plated 200
SC08	1/2" x 2 Steel Counter Sunk Screws 200
SC09	1/2" x 3 Steel Counter Sunk Screws 200

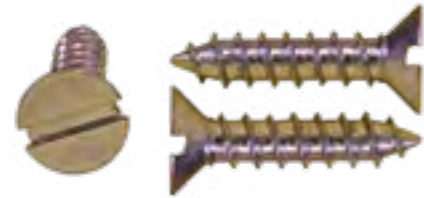

Steel Counter Sunk Pozi Compatible

	Per
SC10	1/2" x 4 Steel Counter Sunk Screws Pozi Compat. 200

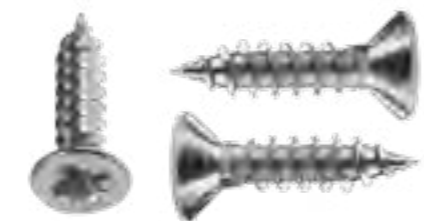

Steel Round Headed

	Per
SRH04	1/2" x 3 Steel Round Head 200

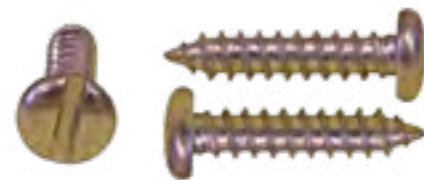

Pozi Round Headed

	Per
POZI01	3/8" x 4 Pozi Round Headed Screws 200
POZI02	1/2" x 4 Pozi Round Headed Screws 200
POZI03	5/8" x 4 Pozi Round Headed Screws 200

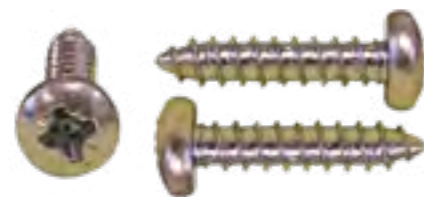

Suggested pins & screws for fittings

Please note that depending on the type of timber, wall, etc that you are fixing in to, the size of the screw/pin may not be suitable. If you are not sure please contact your local branch for more advice.

Butt Hinges

BH911	3/4" x 1 Counter Sunk Steel Screws
-------	------------------------------------

D Rings

DR750		
DR751	Nickel	Any Pozidrive screws we stock or 6/16" x 11 nickel rivets
DR754		
DR755		
DR752	Brassed	3/8" x 4 or 1/2" x 4 round head brass or 6/16" x 11 brassed rivets
DR753		
DR760	Nickel	Any Pozidrive screws we stock or 6/16" x 11 nickel rivets
DR762	Brassed	1/2" x 4 round head brass screws or 6/16" x 11 brassed rivets

Firescreen Handles

FF850	Feet	5/8" x 6 Counter Sunk Brass Screws
FH860	Handles	5/8" x 6 Counter Sunk Brass Screws

Glass Plates

GP2001	1"	5/8" x 2 Counter Sunk Brass Screws
GP2002	1 1/4"	3/2" x 3 Counter Sunk Brass Screws
GP2003	1 1/2"	1/2" x 4 Counter Sunk Brass Screws
GP2315/1	3/4"	3/8" x 2 Counter Sunk Brass Screws
GP2315/2	1"	3/8" x 3 Counter Sunk Brass Screws
GP2315/3	1 1/4"	1/2" x 4 Counter Sunk Brass Screws
GP2315/4	1 1/2"	1/2" x 5 Counter Sunk Brass Screws
GP2315/5	1 3/4"	5/8" x 6 Counter Sunk Brass Screws
GP2315/6	2"	5/8" x 6 Counter Sunk Brass Screws
GP2319/1	1"	3/8" x 4 Counter Sunk Brass Screws
GP2319/2	1 1/4"	1/2" x 4 Counter Sunk Brass Screws
GP2319/3	1 1/2"	1/2" x 5 Counter Sunk Brass Screws
GP2319/4	2"	5/8" x 6 Counter Sunk Brass Screws
GP2321/1	1"	3/8" x 3 Counter Sunk Brass Screws
GP2321/2	1 1/2"	1/2" x 5 Counter Sunk Brass Screws

Plate Hooks

PH296	2 1/4"	Brass	5/8" x 6 Counter Sunk Brass Screws
PH299	2"	Black	3/4" x 6 Counter Sunk Steel Screws
PH298	3"	Black	3/4" x 8 Counter Sunk Steel Screws
PH297	4"	Black	3/4" x 10 Counter Sunk Steel Screws

Plate Rings

PR394	3/4"	3/8" x 2 Counter Sunk Brass Screws
PR396	1"	1/2" x 4 Counter Sunk Brass Screws
PR398	1 1/4"	5/8" x 5 Counter Sunk Brass Screws

Repair Plates

RP2922	1 3/8"	
RP2924	1 5/16"	3/8" x 2 Counter Sunk Brass Screws
RP2926	2 1/4"	

Spring Clips

SC96	1"	3/8" x 3 Round Head Zinc Screws
SC97	1 3/4"	3/8" x 3 Round Head Zinc Screws

Strap Hangers

SH77	1/2" x 6 Round Head Zinc Screws
------	---------------------------------

Strut Hinges

Bars & Clips	5/16" x 14 or 6/16" x 14 Rivets
--------------	---------------------------------

Turn Buttons

T360	1/2"	3/8" x 1 Counter Sunk Steel Screws
T363	5/16"	3/8" x 2 Counter Sunk Brass Screws
T364	5/8"	3/8" x 2 Counter Sunk Brass Screws
T365	3/4"	3/8" x 2 Counter Sunk Brass Screws

Tray Handles

TH666	1/2" x 4 Counter Sunk Brass Screws
TH1553	1/2" x 4 Counter Sunk Brass Screws

Wall Plates

WP67	3/4" x 6 Round Head Zinc Screws
------	---------------------------------

Adhesive Tapes

Adhesive Tapes



From framing to packing, we stock every kind of tape you will need to get the job done.

Adhesive Tapes

If in any doubt, please test any tape before using. Wessex Pictures cannot be held responsible for any damage caused.

Brown Masking Tape

With your work securely inside a frame you will want to keep dust and dirt out, but also make sure the frame looks neat and tidy. Brown masking tape is the usual option for this job. It is self adhesive, flexible and easy to work with. It offers an attractive finish and is cost effective. This product comes in a variety of widths and the rolls are 50m (164') long.

		Per
BMT25	25mm Brown Masking Tape	Roll
BMT38	38mm Brown Masking Tape	Roll
BMT50	50mm Brown Masking Tape	Roll
BMT75	75mm Brown Masking Tape	Roll



Tesa Brown Masking Tape

Similar to our standard brown masking tape, Tesa branded tape is the choice of those demanding the highest quality. Rolls come in various widths and are 50m long. It is flexible, conforming to shapes well and has a long lasting adhesive.

		Per
TMT25	25mm Tesa Brown Masking Tape	Roll
TMT38	38mm Tesa Brown Masking Tape	Roll
TMT50	50mm Tesa Brown Masking Tape	Roll
TMT75	75mm Tesa Brown Masking Tape	Roll



Sekisui 500 Tape

A very popular frame sealing tape. Its light unwinding force enables excellent workability and a special resin treatment makes it highly moisture-proof and gives it excellent durability against high and low temperatures. Rolls are 50m in length.

		Per
SEK1500-25	25mm Sekisui 500 Tape	Roll
SEK1500-38	38mm Sekisui 500 Tape	Roll
SEK1500-50	50mm Sekisui 500 Tape	Roll



Sekisui 504 Tape

A brown frame sealing tape which is self adhesive and sticks in place with hand pressure. The outer face of the tape has a special coating which is very moisture stable, and allows the tape to stick to itself like traditional masking tapes. This allows for overlaps on frame corners. The coating will also accept labels or frame bumpers to be attached and it can also be written on. Rolls are 50m in length.

		Per
SEK1504-25	25mm Sekisui 504 Tape	Roll
SEK1504-38	38mm Sekisui 504 Tape	Roll
SEK1504-50	50mm Sekisui 504 Tape	Roll
SEK1504-75	75mm Sekisui 504 Tape	Roll



Standard Masking Tape

Cream in colour, this economy tape is used for temporary fixing, rather than as a permanent fixing solution. It is available in 2 popular widths and the rolls are 50m in length. This is an 'easy tear' tape.

		Per
SMT25	25mm Standard Masking Tape	Roll
SMT50	48mm Standard Masking Tape	Roll



Scotch® 3M Masking Tape

This cream coloured tape is extremely flexible. It sticks well to most surfaces and even sticks well to itself, allowing for neat overlaps. It comes in three sizes and the rolls are 50m (164') long.

		Per
MT25	25mm Standard Masking Tape	Roll
MT38	36mm Standard Masking Tape	Roll
MT50	48mm Standard Masking Tape	Roll



Clear Tape

This industry standard tape has a multitude of uses from fixing to packing applications. It is low noise. 25mm (1") wide and 50m (164") in length.

		Per
SEL1	Clear Tape	Roll



Scotch® 3M Magic Tape

Scotch® Magic™ Tape is the original matt finish invisible tape. It appears frosty on the roll but becomes almost invisible on paper. It is easy and clean to apply from the roll. Rolls are 19mm (3/4") wide and 33m long.

		Per
SMT1	Scotch Magic Tape	Roll

Scotch® 3M Removable Magic Tape

This versatile tape features the same removable adhesive as the popular Post-it® Notes. It holds securely, yet can be removed and repositioned. It's great for cut-and-paste and temporary holding applications. As with normal magic tape it disappears on paper. It pulls off the roll smoothly and cuts easily. Rolls are 19mm (3/4") wide and 33m long.

		Per
SMT2	Scotch Removable Magic Tape	Roll



Vinyl Packing Tape

To finish off and secure all your packing our 48mm wide polypropylene packing tape is the perfect choice. It is low noise and easy tear. Rolls are 66m long and it comes on a standard 3" core to fit standard tape dispensers.

		Per
PT1	48mm Vinyl Packing Tape	Roll



Gummed Tapes

Gummed Paper Tape

Available in two widths, this tape works by wetting it thoroughly before application. It is a very economical way of taping frame backs. It is made from brown craft paper and the rolls are 200M (656') long. Storage note – avoid cold/damp storage conditions as this can cause the tape to wrinkle on the roll.

		Per
GM3	48mm Gummed Paper Tape	Roll
GM4	70mm Gummed Paper Tape	Roll



Double Sided Tapes

Finger Lift Double Sided Tape

The difference with 'finger lift' tapes to normal double sided tape is that its release paper is a couple of mm wider than the adhesive layer, meaning you can easily lift the edge with your finger, rather than your fingernails or a craft blade. It comes in two widths and 50m (164') in length.

		Per
FL1	6mm Finger Lift Double Sided	Roll
FL2	12mm Finger Lift Double Sided	Roll



25mm Double Sided Tape

Similar to ATG tape in its usage – it varies in that it is applied by hand and features a top protective release paper. Peel the release away to expose the adhesive prior to use. It has a high grab adhesive and works well on all flat surfaces. Rolls are 25mm (1") wide and 50m (164') long.

		Per
DS1	25mm Double Sided Tape	Roll



Double Sided Adhesive Transfer Tape

A cost effective standard ATG tape that can be applied by hand and works with our TG1 Tape gun applicator (see page 165). Simply pull the tape or tape gun across the surface of paper or board to leave a trail of strong dry adhesive. Commonly used for bonding double mounts and float mounting applications. 12mm wide and 33m in length.

		Per
456-1/2	12mm Double Sided Adhesive Transfer Tape	Roll



Scotch® 3M ATG Tape 904

Commonly known as ATG tape. This tape works with our TG1 Tape gun applicator (see page 165) and is fast and easy to use. Simply pull the gun across the surface of paper or board to leave a trail of strong dry adhesive. It is commonly used for bonding double mounts and float mounting applications. It has a high initial bond and is very long lasting. Rolls are 12mm (½") wide and 25m (82') long.

		Per
SC1	12mm 904 ATG Double Sided Tape	Roll



Tapestry Tape

This tape is commonly used for mounting down or stretching fabrics. It is very sticky! Commonly it is taped around the back edge of a sturdy board, such as MDF or hardboard. The board is then placed over the fabric - which should be face down and larger than the backing board. Once positioned on the fabric, the edges of the fabric are pulled round and smoothed firmly on to the exposed tapestry tape. This is not regarded as a conservation framing method. Rolls are 50m (164') in length.

		Per
DSC1	25mm Double Sided Tapestry Tape	Roll
DSC2	50mm Double Sided Tapestry Tape	Roll



Acid Free Tapes

Conservation ATG Tape

A "conservation" version of ATG tape that works in the same way as normal ATG tape. The adhesive is a water based, acid neutral acrylic adhesive. Available in two widths and 30m long. It offers a permanent bond and works with our TG1 gun applicator (see page 165).

		Per
CATG1	12mm Conservation ATG Tape	Roll
CATG2	19mm Conservation ATG Tape	Roll



Double Sided Conservation Fillet Tape

A double sided polyester tape with an acrylic adhesive, ideal for use on plastic, paper or paper wrapped spacers or fillets. The thick polyester acts as a barrier to stop acid penetrating through. The archival acrylic adhesive is non ageing and will not turn yellow. Rolls are 6mm (¼") wide and 50m (164 ft) long.

		Per
FT06	Double Sided Conservation Fillet Tape	Roll



Acid Free Tapes

24mm Self Adhesive Tape

This tape is ideal for hinging artwork to either mounts or backing boards. It is just under 1" wide (24mm) and rolls are 55m long. This product is pH neutral and acid free so it will not attack artwork.

	Per
PHNT1 24mm Self Adhesive White	Roll



Self Adhesive Acid Free Tape

PH7-70 is used for hinging of all types of paper artwork. It has a white, acid free paper base and water based acrylic adhesive. It does not have a peel off release paper, but it is sticky at room temperature. It is 'non ageing' and will not turn yellow. It comes in two popular widths and rolls are 66m (216') long.

	Per
PH7-70 25mm Self Adhesive Acid Free Tape	Roll
PH7-71 38mm Self Adhesive Acid Free Tape	Roll



Self Adhesive Hinging Tissue

This pressure sensitive, mounting and hinging tape features a fine, long fibered, translucent tissue with an archival quality pressure sensitive acrylic adhesive that is permanent and non-yellowing. It is ideal for hinging translucent art such as Japanese paper, papyrus, and other light weight art because it won't show through. If you are attempting removal, mineral spirits are required. Rolls are 10m (33') in length.

	Per
LINECO5 25mm Self Adhesive Hinging Tissue	Roll



Self Adhesive Linen Hinging Tape

This pressure sensitive linen tape is a favourite for hinging window mounts to backboard or attaching art. The very fine linen cloth is flexible yet strong. The neutral pH acrylic adhesive gains strength overnight. Rolls are 10m (33') in length.

	Per
LINECO6 32mm Self Adhesive Linen Hinging Tape	Roll



Filmoplast P90 Tape

The favourite film from Neschen. It is long fibered, wood free and acid free and widely regarded as the industry standard tape for hinging artwork to mounts or backing boards. Rolls are 50m (164') in length. The box it is supplied in works as a handy dispenser.

	Per
P90 20mm Filmoplast S/A Acid Free Tape	Roll



Filmoplast P90 Plus Acid Free Tape

While most other Filmoplast tapes were first designed for use in archives, Filmoplast P90 Plus has been specifically designed for fine art hinging. It features a 50g/m² white long fibered acid free tape and the adhesive used is a refined version of the original formula. It provides better initial and final bond strength, whilst still retaining the same stable ageing characteristics. Rolls are 50m (164') in length.

	Per
P90PLUS 20mm Filmoplast S/A Acid Free Tape	Roll



Filmoplast P Tape

Filmoplast 'P' is a very thin paper tissue that is ideal for hinging thin or fragile papers. It can be removed from sturdy paper surfaces with water. Rolls are 50m (164') in length. The box it is supplied in works as a handy dispenser.

	Per
FILMOP 20mm Transparent S/A Acid Free Tape	Roll



Filmoplast Linen Tape

Made from an acid free, non-tear, fine threaded textile – this tape is ideal for hinge mounting heavy artwork and has a pH neutral adhesive. It has a peel off release paper to protect the adhesive prior to use. Rolls are 50m (164') in length.

	Per
FILMOSH 20mm Linen S/A Acid Free Tape	Roll



Acid Free Tapes

Japanese Acid Free Paper

If you prefer to make your hinges completely from "scratch" then this is your starting point. Japanese acid free paper is ideal for wet repairs, hinging and mounting works of art on paper. The paper is manufactured without buffers or optical brightening agents (OBA free). The paper is only 9gsm but is still very strong and retains a supple nature. When making your hinges use this in conjunction with pH neutral adhesive (page 267). Rolls are 20mm wide and 150m in length.

JAFP1 Japanese Acid Free Paper Per Roll



Archival Gummed Paper Tape

Similar to Archival gummed linen tape, this paper tape is also coated with a water activated adhesive layer that is pH neutral. It is suitable for hinging, mounting and repairs – on most types of paper artwork. The adhesive will not yellow and is removable with water from most stable surfaces. Rolls are 10m (33') in length.

AGPT1 25mm Archival Gummed Paper Tape Per Roll



Archival Gummed Linen Tape

Made from acid free linen, this tape is coated with a water activated adhesive layer that is also pH neutral. Linen tape is very strong and perfect for hinging, mounting and repairs – especially on heavy artwork. The adhesive will not yellow and is removable with water from most stable surfaces. Rolls are 10m (33') in length.

AGLT1 24mm Archival Gummed Linen Tape Per Roll



Gummed Linen Hinging Tape

This water activated cloth tape has a high thread count, which provides superior strength for hinging, mounting or repair applications. The neutral pH adhesive has high tack, lay flat properties that make it a favourite for hinging mounts and heavy pieces of artwork. The adhesive is reversible with water. Rolls are 9m (29½') in length.

LINECO2 25mm Gummed Linen Hinging Tape Per Roll



Gummed Paper Hinging Tape

This is a conservation quality white paper tape with a water activated neutral pH adhesive. It is suitable for all kinds of hinging applications apart from the heaviest works of art. The paper is acid-free and lignin-free with a calcium carbonate buffer and a pH of 8.5. For the best quality results it is recommended that distilled water is used to activate it. It is also reversible with water at a later date. Rolls are 40m (130 ft) long and 25mm (1") Wide.

LINECO3 25mm Gummed Paper Hinging Tape Per Roll



Frame Sealing Tape

The core of this special tape is made from impervious aluminium foil, with a blue grey acid free backing paper. The pressure sensitive adhesive is inert and very strong. It bonds permanently to woods, metal and boards. It "shapes" very easily over contours to provide a neat finish to frame backs. Please note that it can only be reversed with mineral spirits and should never be applied directly to artwork. Rolls are 25m (82') in length.

LINECO4 32mm Frame Sealing Tape Per Roll



Dispensers & Guns

Desk Tape Dispenser

This handy desk or work top dispenser works as easily with masking and self adhesive tapes as it does with conventional 'cellotape' type products. It features a serrated blade for cutting tape and the core holder offers simple replacement of rolls.

DESK Desk Tape Dispenser Each



Double Sided Tape Gun

A handy gun for dispensing double sided adhesive to the back of mounts and overlays. The gun offers one handed operation and is fast and clean in use. Its unique gearing system allows adhesive to be simply applied and the waste carrier paper to be collected inside the gun itself. Please note the colour of the gun may vary from batch to batch.

TG1 Double Sided Tape Gun Each



Tools and Equipment

Tools & Equipment



Choosing the right equipment is key to every successful framing job. Wessex pictures can supply everything you will need to create a professional finish.



Morsø-F

Foot operated mitring machine

Technical data

Double mitre	45°
Single mitre up to	90°
Cutting width, max.	100mm
Cutting height, max.	160mm
Square cutting	65/65mm
Measuring scale up to	1500mm
Net weight	90kg

- No compressor or electricity required
- Tenons, mortice joints and a wide variety of angled cuts can be made
- Less than 1mm of moulding waste
- Accurate repeat work with the sliding longitudinal stop and measuring scale
- Horizontal movement of the knife block is stepwise adjustable
- Twin return springs automatically bring the knives back to the starting position
- Easy operation with the lever system
- Dust free operation

Delivered with

Safety guard Waste chute
 Sliding longitudinal stop Measuring scale
 Adjustable fences, 45° - 90°
 Adjustable rebate supports

Optional accessory

Automatic rebate support system



MR1 Morsø F Mitring Machine Each
 LHE1 Left Hand Extension for guillotine Each

LHE1



Morsø-F Plus 10

Foot operated mitring machine for the taller operator

Technical data

Double mitre	45°
Single mitre up to	90°
Cutting width, max.	100mm
Cutting height, max.	160mm
Square cutting	65/65mm
Measuring scale up to	1500mm
Up to 2500 on request	
Net weight	90kg

- No compressor or electricity required
- 100mm increased working table height
Foot pedal working height remains the same
- Tenons, mortice joints and a wide variety of angled cuts can be made
- Less than 1mm of moulding waste
- Accurate repeat work with the sliding longitudinal stop and measuring scale
- Horizontal movement of the knife block is stepwise adjustable
- Twin return springs automatically bring the knives back to the starting position
- Easy operation with the lever system
- Dust free operation

Delivered with

Safety guard Waste chute
 Left hand extension table
 Sliding longitudinal stop Measuring scale
 Adjustable fences, 45° - 90°
 Automatic rebate support system



MR4 Morsø F Mitring Machine PLUS 10 Each



Morsø-EH

Electric / hydraulic mitring machine

Technical data

Double mitre	45°
Single mitre up to	90°
Cutting width, max.	100mm
Cutting height, max.	180mm
Square cutting	70/70mm
Measuring scale up to	1500mm
Net weight	135kg
Motor, single / three phase	1.1kW
Pumping capacity	7 litre/min
Working pressure	80 bar
Power transmission	660kg
Tank contents	8 litre
Noise level	Below 70dB

The Morsø EH does the same work as the Morsø F, but it is fully automatic.

- Automatic cutting cycles for large and small mouldings - the machine does the trim cut
- Adjustable length of stroke (3 positions)
On the lowest cutting position the cutting cycle of two cuts only takes 1-1.5 seconds
- Measuring scale with two adjustable stops
Cut the long and short lengths of a frame without having to re-adjust the measurements
- Two hand release safety operation

Delivered with

Safety guard Waste chute
 Extension table for the left side
 Sliding longitudinal stop Measuring scale
 Adjustable fences, 45° - 90°
 Automatic rebate support system
 Moulding clamps

MR10 Morsø EH Mitring Machine Each



Morsø-EH Turbo

The same machine as the Morsø-EH but with a 50% faster working cycle.

MR17 Morsø EH Turbo Mitring Machine Each



Morsø-EH Digital

Electric / hydraulic mitring machine

Technical data

Double mitre	45°
Single mitre up to	90°
Cutting width, max.	100mm
Cutting height, max.	180mm
Square cutting	70/70mm
Measuring scale up to	1500mm
Net weight	135kg
Motor, single / three phase	1.1kW
Pumping capacity	7 litre/min
Working pressure	80 bar
Power transmission	660kg
Tank contents	8 litre
Noise level	Below 70dB

Identical to the Morsø EH but with a touch screen display for easier settings and more adjustments.

- Automatic cutting cycles for large and small mouldings - the machine does the trim cut
- Adjustable length of stroke (3 positions)
On the lowest cutting position the cutting cycle of two cuts only takes 1-1.5 seconds
- Measuring scale with two adjustable stops
Cut the long and short lengths of a frame without having to re-adjust the measurements
- Two hand release safety operation
- Automatic switch off after a certain time

Delivered with

Safety guard Waste chute
 Extension table for the left side
 Sliding longitudinal stop Measuring scale
 Adjustable fences, 45° - 90°
 Automatic rebate support system
 Moulding clamps

MR12 Morsø EH Digital Mitring Machine Each





Morsø-EFG Electric

Fully automatic electric mitring machine

Technical data

Double mitre	45°
Single mitre up to	90°
Cutting width, max.	100mm
Cutting height, max.	180mm
Square cutting	70/70mm
Measuring scale up to	1500mm
Motor, three phase	0.55kW
Net weight	135kg
Noise level	0dB

- Horizontal movement of the knife block is adjustable up to 60mm
- Vertical movement of the knife block is adjustable with three different heights
Position 1 - small work pieces
Position 2 - medium work pieces
Position 3 - thick work pieces up to 180mm
- Cutting cycle of two cuts is from 1 second depending on the thickness of the work piece
- Two hand release safety operation

Delivered with

- Safety guard Waste chute
- Extension table for the left side
- Sliding longitudinal stop Measuring scale
- Adjustable fences, 45° - 90°
- Adjustable and automatic rebate supports
- Clamping cylinders

MR15 Morsø EFG Electric Mitring Machine Each



Morsø Accessories

Digital Measuring System

This manually operated system can be delivered with any new Morsø mitring machine, or installed onto an existing machine no matter how old it is.

The digital measuring system consists of two small, compact units with low power LCD metric / decimal-inch displays.

One unit is for the outside and inside frame measurements, the other measures the width of the rebate. The precision is unique as the display can show up to 0.01mm. Both displays are battery operated - 1.5 VDC to 3 VDC - and have a long service life without battery change.

MR14 Digital Measuring System Each



Automatic Rebate Support Attachments

These attachments reset the rebate supports to the adjusted width and height of the moulding after each cutting cycle, saving time on manual adjustments and ideal for repetition work.

They fit the Morsø F, Morsø F De-Luxe, Morsø FC and Morsø H mitring machines. They come as standard on the Morsø F plus Ten and Morsø EH.

The rebate supports are not supplied with the automatic rebate support attachment. The existing rebate supports on the machine are used.

MR16 Automatic Rebate Support Attachments Per Pair



Safety Guard

This makes older Morsø machines safer, preventing the operator from touching the knives. The guard fits over the moving blade head and is adjustable.

It comes as standard on all new Morsø machines.

MR5 Morsø Safety Guard inc. Fittings Each



Rubbish Chute

The chute is easily fitted onto the Morsø F models. No screws or drilling necessary. It will divert the waste straight to any box placed behind the machine. It comes as standard on all new models.

MR3 Morsø Rubbish Chute Each



Folding Roller Stand

The Folding Roller Stand has a single chromed roller with bearings for smooth running. It is ideal for applications where a straight feed is required, such as a Morsø. It is lightweight and the rear leg is hinged and folds flat so that it can be hung on the wall when not in use. A lever handle sets the height from 660mm to 1100mm to suit your application.

MR11 Folding Roller Stand Each



Morsø Spares

Morsø Rebate Supports

Left / right side supports that slide into the guides.

MR7 Morsø Rebate Supports Per Pair



Morsø High Rebate Supports

Manually adjustable especially for deep box framing. Supports from 40mm – 70mm tall rebates.

MR9 Morsø High Rebate Supports Per Pair



Morsø Springs

2x large springs that pull Morsø blades / foot pedal to the uppermost position.

MR9 Morsø Springs Per Pair



Morsø Blades

Wessex Pictures only supply genuine Morsø blades. Manufactured from a special hardened steel (HR64) they are proven to be harder than any other blades available. They are precision ground and honed and can last up to 6 times longer than other brands.

Standard Morsø Blades

Replacement blades for Morsø mitring machines.

MR2 Standard Morsø Blades Per Pair



Reversible Morsø Blades

Standard double ended reversible blades fit most Morsø machines. Max cutting width approx. 40mm.

MR13 Reversible Morsø Blades Per Pair



Morsø Blades Box

Genuine Morsø blades box for safe transportation of your guillotine blades. The blades and lid are held firmly in place by two bolts.

MR8 Morsø Blades Box Each



Blade Sharpening

Wessex Pictures offer a professional hollow ground sharpening service for excellent blade performance

Benefits of Hollow Ground Blades

- Blade longevity
- Precision of the cut
- Improved overall finish of the frame
- Consistent quality and craftsmanship



The service includes

- Collection and delivery via the Wessex van service
- Standard 10 - 14 day turnaround
- We sharpen most makes of blades

SRB2 Set of Blades Reground Per Set



C18 Plus

Electro-pneumatic Double Mitre Saw

Technical data

Machine width	1080mm
Machine height	1580mm
Machine length	820mm
Net weight	380kg
2 x blades diameter	275mm - 380mm
Cutting width - max.	102mm
Cutting height - max.	100mm
Cuts per hour	300 - 400
Motors, three phase	2 x 2hp
Compressed air	6 bar
Sawdust exhaust outlet	100mm diameter
Noise level	80dB

- Pneumatic clamps
- Pneumatic sliding stop - fixed fence
- Vertical pneumatic stroke for 45° 'V' cutting at both ends
- Vertical up and down movement
- Precise and high quality cuts in soft and hard woods, plastics, MDF and aluminium profiles
- Recommended for a medium to large production volume
- Maximum operator safety

C18PLUS Brevetti Mitre Saw Each



C20 Plus

Electro-pneumatic Double Mitre Saw

Technical data

Machine width	1080mm
Machine height	1580mm
Machine length	820mm
Net weight	380kg
2 x blades diameter	275mm - 380mm
Cutting width - max.	102mm
Cutting height - max.	100mm
Cuts per hour	300 - 400
Motors, three phase	2 x 2hp
Compressed air	6 bar
Sawdust exhaust outlet	100mm diameter
Noise level	80dB

- Pneumatic clamps
- Adjustable fence for faster cutting operations
- Vertical pneumatic stroke for 45° 'V' cutting at both ends
- Vertical up and down movement
- Precise and high quality cuts in soft and hard woods, plastics, MDF and aluminium profiles
- Adaptable for special works such as notching cuts, very high profiles (for boxes), and heavy aluminium elements
- Recommended for a medium to large production volume
- Maximum operator safety

C20PLUS Brevetti Mitre Saw Each





Jaguar

Electro-pneumatic Double Mitre Saw

Technical data

Machine width	820mm
Machine height	1400mm
Machine length	1080mm
Net weight	270kg
2 x blades diameter	300mm
Cutting width - max.	78mm
Cutting height - max.	80mm
Cuts per hour	200
Motors, three phase	2 x 1.5hp
Compressed air	6 bar
Sawdust exhaust outlet	100mm diameter
Noise level	85dB

- Fixed fence
- Pneumatic vertical clamps
- Vertical pneumatic stroke for 45° 'V' cutting at both ends
- Swinging down movement
- Precise and high quality cuts in soft and hard woods, plastics, MDF and aluminium profiles
- Ideal for cutting glazing beads and profiles of small and medium width
- Suitable for small to medium production volumes
- Maximum operator safety

JAGUAR Brevetti Mitre Saw Each



Prisma-CE

Double Headed Mitre Saw

Technical data

Machine width	1180mm
Machine height	1100mm
Machine length	670mm
Net weight	165kg
2 x blades diameter	250mm - 275mm
Cutting width	120mm
Cutting height	80mm
Cuts per hour	200
Motors, single phase	2 x 1.5hp
Sawdust exhaust outlet	100mm diameter
Noise level	80dB

- Fixed fence
- Manual horizontal stroke for 45° 'V' cutting at both ends
- No crushing or chipping of mouldings
- Precise and high quality cuts in soft and hard woods, plastics, MDF and aluminium profiles
- Suitable for small - medium production volumes
- Maximum operator safety

PRISMA-CE Brevetti Mitre Saw Each





Super Prisma

Double Headed Mitre Saw

Technical data

Machine width	1340mm
Machine height	1150mm
Machine length	670mm
Net weight	181kg
2 x blades diameter	250mm - 275mm
Cutting width	150mm
Cutting height	80mm
Cuts per hour	200
Motors, single phase	2 x 1.5hp
Sawdust exhaust outlet	100mm diameter
Noise level	80dB

- Fixed fence
- Manual operation pulling one blade at a time
- Manual horizontal stroke for 45° 'V' cutting at both ends
- No crushing or chipping of mouldings
- Precise and high quality cuts in soft and hard woods - PS and all MDF materials
- Suitable for cutting aluminium profiles
- Particularly suitable for smaller production volumes and wider profiles
- Maximum operator safety

SUPERPRISMA Brevetti Mitre Saw Each



AUT-2100

Electro-pneumatic Coil Fed Underpinner

Technical data

Machine width	790mm
Machine height	1300mm
Machine length	850mm
Net weight	155kg
Production rate per hour	300 frames
Motors, single phase	0.3 kW
Compressed air	6 bar
Noise level	73dB

- Up to 10 different joining positions
- More than 1000 profiles memory
- Wide joining capacity
- Wedges in coils type NR for MDF and hard wood profiles
- Wedges in coils type VC or VM for soft woods
- Designed specifically for high usage
- Maximum operator safety

AUT2100 Brevetti Coil-fed Underpinner Each





AUT-2112

Electro-pneumatic
Coil Fed Hot Glue Underpinner

Technical data

Machine width	850mm
Machine height	1300mm
Machine length	1100mm
Net weight	185kg
Production rate per hour	200 frames
Motors, single phase	2 kW
Compressed air	6 bar
Noise level	73dB

- Up to 10 different joining positions
- More than 1000 profiles memory
- Wide joining capacity
- Wedges in coils type NR for MDF and hard wood profiles
- Wedges in coils type VC or VM for soft woods
- Equipped with automatic gluer for hot melt or cold glue
- Designed specifically for high usage
- Maximum operator safety

AUT2112	Brevetti Coil-fed Hot Glue Underpinner	Each
---------	---	------



Smart

Air Operated Underpinner

Technical data

Machine width	400mm
Machine height	1150mm
Machine length	420mm
Net weight	60kg
Production rate per hour	100 frames
Compressed air	6 bar
Noise level	73dB

- Automatically adjusts to different moulding heights
- Allows 2 set positions and can double stack
- Fires NP wedges for MDF and hard wood profiles
- Fires PV wedges for soft woods and plastics
- Front safety shield - Max. operator safety
- Suitable for small - medium production volume

SMART	Brevetti Air Operated Underpinner	Each
-------	-----------------------------------	------





Simple

Pneumatic Table Top Underpinner

Technical data

Machine width	360mm
Machine height	580mm
Machine length	520mm
Net weight	30kg
Production rate per hour	100 frames
Compressed air	6 bar
Noise level	74dB

- Can join butt joints (90° cuts) or curved parts with alternative fences
- Takes type NP wedges for MDF and hard wood profiles
- Takes type PV wedges for all mouldings and PVC profiles
- Front safety shield - maximum operator safety
- Suitable for small - medium production volume

SIMPLE Brevetti Simple Air Underpinner Each



Blades & Wedges

Saw Blades - 30mm Bore

R910	Wood - 350mm	Each
R911	Wood - 300mm	Each

Saw Blades - 32mm Bore

R900	Wood - 200mm	Each
R902	Wood - 250mm	Each
R904	Wood - 275mm	Each
R906	Wood - 300mm	Each
R908	Wood - 350mm	Each
R920	Wood/Aluminium - 200mm	Each
R922	Wood/Aluminium - 250mm	Each
R924	Wood/Aluminium - 275mm	Each
R926	Wood/Aluminium - 300mm	Each
R928	Wood/Aluminium - 350mm	Each



Brevetti Coil-Fed Wedges

VC coil-fed wedges - for smaller mouldings

		Per
VC04	4mm VC Wedges	20000
VC06	6mm VC Wedges	15000
VC08	8mm VC Wedges	15000
VC10	10mm VC Wedges	15000
VC12	12mm VC Wedges	10000
VC16	16mm VC Wedges	10000

NR coil-fed wedges - for hard woods and MDF

		Per
NR04	4mm NR Wedges	20000
NR06	6mm NR Wedges	15000
NR08	8mm NR Wedges	15000
NR10	10mm NR Wedges	15000
NR12	12mm NR Wedges	10000
NR16	16mm NR Wedges	10000

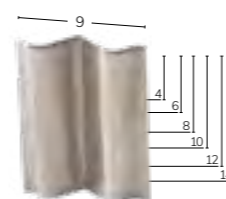

VC Wedges

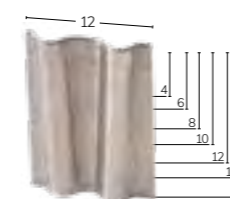

NR Wedges

Brevetti Strip Wedges

PV wedges - for soft woods and plastics

		Per
PV06	6mm PV Wedges	6000
PV08	8mm PV Wedges	5000
PV10	10mm PV Wedges	4000
PV12	12mm PV Wedges	3000

NP wedges - for hard woods and MDF

		Per
NP06	6mm NP Wedges	6000
NP08	8mm NP Wedges	5000
NP10	10mm NP Wedges	4000
NP12	12mm NP Wedges	3000
NP14	14mm NP Wedges	2000
NP16	16mm NP Wedges	2000

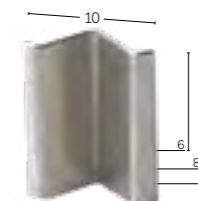

PV Wedges

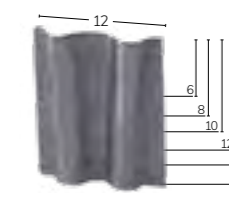

NP Wedges

A1-MXL

Manual Underpinner

Technical data

Machine width	400mm
Machine height	1410mm
Machine depth	500mm
Net weight	50kg
Min. frame section (W/H)	6mm x 6mm
Max. frame section (W/H)	150mm x 100mm

- Fully manual foot operated underpinner
- Extra strong nail driver providing trouble free operation for many years
- Sturdy floor stand for extra stability
- Can be used from both front and back
- Designed for easy wedge loading
- Two adjustable wedge stops
- Wedge magazine capacity - 200
- Standard wedge size - 7mm 10mm 15mm
- Optional wedge size - 5mm 12mm
- Joins all types of mouldings

A+A1M A1-MXL Manual Underpinner Each



Optional extras

- 12mm claw head
- Metal extension wings

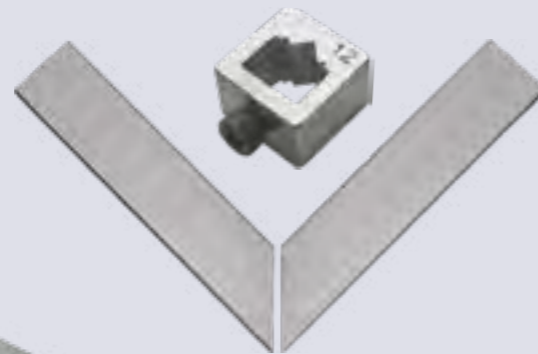

A3-P

Bench Top Pneumatic Underpinner

Technical data

Machine width	320mm
Machine height	380mm
Machine depth	480mm
Net weight	50kg
Min. frame section (W/H)	6mm x 6mm
Max. frame section (W/H)	150mm x 100mm
Wedge magazine capacity	220
Working pressure	40 - 80 PSI
Air consumption	0.12 ft ³ @ 73 PSI

- Extra strong nail driver providing trouble free operation for many years
- Can be used from both front and back
- Horizontal clamp to hold the corners tightly together while assembling the frames
- The fence is moved along linear ball bearings
- The automatic fence clamp lies below the working surface
- Double stage foot pedal for horizontal clamping and firing the wedge
- Designed for easy wedge loading
- Two adjustable wedge stops
- Standard wedge size - 7mm 10mm 15mm
- Optional wedge size - 5mm 12mm
- Joins all types of mouldings

A+A3P A3-P Pneumatic Underpinner Each

Optional extras

- 12mm claw head
- Metal extension wings
- Floor stand

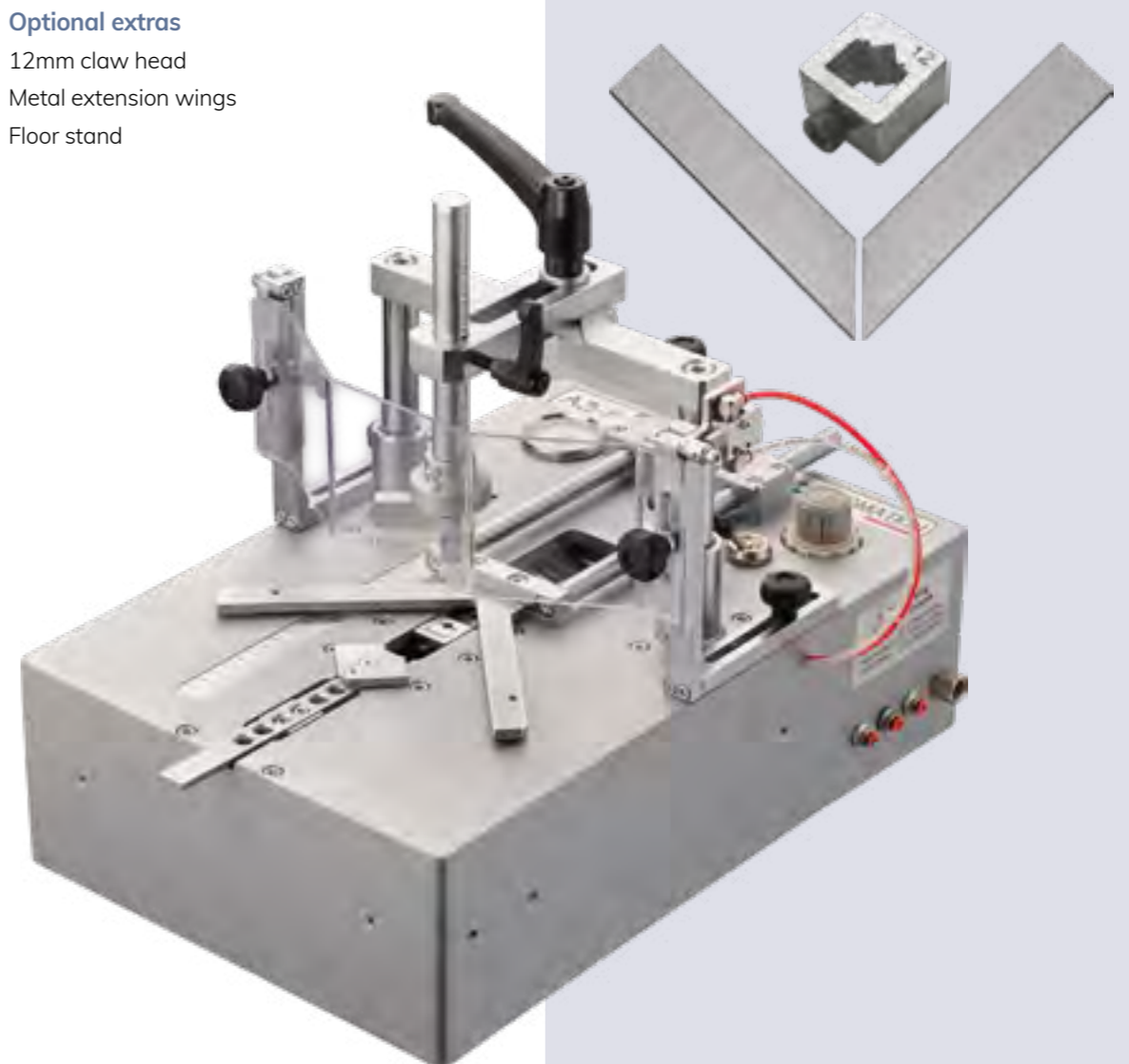

A44-P

Pneumatic Underpinner

Technical data

Machine width	880mm
Machine height	1400mm
Machine depth	680mm
Net weight	135kg
Wedge magazine capacity	220
Working pressure	70 - 100 PSI
Air consumption	0.14 ft ³ @ 73 PSI
Power supply	220V 50Hz 110V 60Hz

- Extra strong nail driver providing trouble free operation for many years
- Can be used from both front and back
- Tilting floor stand which allows operators to assemble very large frames on their own
- Compensation cylinder to lighten the firing unit when working in the tilted position
- Horizontal clamp to hold the corners tightly together while assembling the frames
- Single stage foot pedal for horizontal clamping
- Min. frame section (W/H) - 6mm x 10mm
- Max. frame section (W/H) - 107mm x 110mm
- Standard wedge size - 7mm 10mm 15mm
- Optional wedge size - 5mm 12mm
- Joins all types of mouldings

A+A44P A44-P Pneumatic Underpinner Each



A5 MemoTS

Electronic Underpinner

Technical data

Machine width	880mm
Machine height	1040mm
Machine depth	680mm
Net weight	135kg
Wedge magazine capacity	220
Working pressure	70 - 100 PSI
Air consumption	0.14 ft ³ @ 73 PSI
Power supply	220V 50Hz 110V 60Hz

- Designed for the framer that requires high speed assembly with frequent changeovers
- Capacity to store 1000's of programmes
- Extra strong nail driver providing trouble free operation for many years
- Can be used from both front and back
- Hydraulic clamp
- Wedges can be driven or stacked in up to 14 positions per corner
- Standard wedge size - 7mm 10mm 15mm
- Optional wedge size - 5mm 12mm
- Min. frame section (W/H) - 6mm x 10mm
- Max. frame section (W/H) - 107mm x 110mm
- Joins all types of mouldings

A+A5MEMOTS
A5 MemoTS Pneumatic Underpinner Each



A6 MemoTS+

Electronic Underpinner

Technical data

Machine width	880mm
Machine height	1400mm
Machine depth	680mm
Net weight	135kg
Wedge magazine capacity	220
Working pressure	70 - 100 PSI
Air consumption	0.14 ft ³ @ 73 PSI
Power supply	220V 50Hz 110V 60Hz



- Designed for the framer that requires high speed assembly with frequent changeovers
- Capacity to store 1000's of programmes
- Extra strong nail driver providing trouble free operation for many years
- Can be used from both front and back
- Double hydraulic clamp
- 5 channel magazine for 5mm, 7mm, 10mm, 12mm and 15mm wedges
- Wedges can be driven or stacked in up to 14 positions per corner
- Horizontal and vertical fence clamps for precise clamping
- Adjustable fence clamps with tightening device
- Digital pressure gauge
- Min. frame section (W/H) - 6mm x 10mm
- Max. frame section (W/H) - 107mm x 110mm
- Joins all types of mouldings

A+A6MEMOTS+
A6 MemoTS+ Pneumatic Underpinner Each

A+ Wedges

A+ Type 11 Wedges

		Per
A+W07	7mm A+ Type 11 Wedges	4000
A+W07HW	7mm A+ Type 11 Hardwood Wedges	4000
A+W10	10mm A+ Type 11 Wedges	3000
A+W10HW	10mm A+ Type 11 Hardwood Wedges	3000
A+W12	12mm A+ Type 11 Wedges	3000
A+W12HW	12mm A+ Type 11 Hardwood Wedges	3000
A+W15	15mm A+ Type 11 Wedges	2000
A+W15HW	15mm A+ Type 11 Hardwood Wedges	2000



A+ UNI Wedges

The A+ Universal Wedges have been designed to fit a range of other underpinners. They will fit Cassese UNI machines but can also be used as a refill for the Cassese empty plastic cartridges. For those that have no empty plastic cartridges the A+ Metal Wedge Cartridges are a reusable option.

		Per
UNIA+07HW	7mm Hardwood A+ Uni Wedges	4000
UNIA+07SW	7mm Softwood A+ Uni Wedges	4000
UNIA+10HW	10mm Hardwood A+ Uni Wedges	3000
UNIA+10SW	10mm Softwood A+ Uni Wedges	3000
UNIA+12HW	12mm Hardwood A+ Uni Wedges	3000
UNIA+12SW	12mm Softwood A+ Uni Wedges	3000
UNIA+15HW	15mm Hardwood A+ Uni Wedges	2000
UNIA+15SW	15mm Softwood A+ Uni Wedges	2000



A+ Refillable Metal Wedge Cartridges

The A+ Metal Wedge Cartridges have been designed specifically as a reusable solution for the Cassese CART machines. Available in four sizes and they take the A+ UNI wedges.

A+MC07	A+ Metal Wedge Cartridge 7mm	Each
A+MC10	A+ Metal Wedge Cartridge 10mm	Each
A+MC12	A+ Metal Wedge Cartridge 12mm	Each
A+MC15	A+ Metal Wedge Cartridge 15mm	Each



Gielle Wedges

Gielle Underpinner Wedges

Works with both soft and hardwoods.

		Per
GIELLE07	7mm Gielle Underpinner Wedges	5000
GIELLE10	10mm Gielle Underpinner Wedges	3000
GIELLE12	12mm Gielle Underpinner Wedges	3000
GIELLE15	15mm Gielle Underpinner Wedges	2000



Ultimat Futura

Fast precision cutting for every type and thickness of mountboard.

The Ultimat Futura is the easiest to use precision mountboard cutter on the market. With unequalled blade control and micro-stop calibration, you are assured of complete accuracy. You will create a perfect mount bevel and exact corners without over or undercutting, every time.

The smooth sliding action requires minimum effort, even when you are cutting through 8 ply mount board.

With the Ultimat Futura you can easily switch between different types of board and thicknesses, in seconds.



Key features:

- Manufactured in the UK
- Consistent faultless mounts
- No more overcuts or undercuts
- Unequalled blade control and effortless cutting
- Unique roller lift and hold system
- Perfect ergonomics
- Bevel and vertical blade holders
- Quick fitting interchangeable guides
- 5 year comprehensive warranty
- 20 year guarantee on all bearings

Optional accessories:

- 2 x 60cm support arms
- 75cm mat guide kit with 60cm arms
- Multi-angle cutting gauge
- Reverse bevel stop

Blades:

See page 212 for blade details



FUTU1000	Keencut Ultimat Futura 40"	Each
FUTU1200	Keencut Ultimat Futura 48"	Each
FUTU1500	Keencut Ultimat Futura 60"	Each

Dimensions

	FUTU1000	FUTU1200	FUTU1500
Cut length	100cm	120cm	150cm
Machine width	124cm	144cm	174cm
Machine depth	39cm	39cm	39cm
Net weight	18kg	20kg	23kg





GCW3



Excalibur 5000

Easy accurate cutting of all picture framing sheet materials.

With the Excalibur 5000 you can instantly swap from cutting mountboard, to glass, to MDF. It combines two cutting heads which house four cutting tools mounted for instant selection. All blades cut down the same line so that all materials are square and accurately cut to ensure a perfect frame fit.

The integral counterbalance ensures an easy glide cutting action and prevents damage when loading sheet materials.

Alignment is fast and easy with the flip in/out measuring stops. They help whether you are setting up for a one-off job or volume production cutting.



Key features:

- Fast, repeatable precision accuracy
- All tools are permanently mounted for instant selection
- The pressure-sensitive clamp protects delicate surfaces from damage
- The one-piece horizontal squaring arm ensures positioning and rigidity either side of the cut line
- Easy cutting motion reduces fatigue

Dimensions

	EX5000	EX5000/60
Cut length	122cm	160cm
Machine height	208cm	244cm
Machine width	213cm	213cm
Packed weight	56kg	67kg

EX5000	Keencut Excalibur 5000 48" Cutter	Each
EX5000/60	Keencut Excalibur 5000 60" Cutter	Each
GCW3	Glass Wheel Assembly	Each



Excalibur 6000

Easy accurate cutting of all picture framing sheet materials.

The Excalibur 6000 combines all the excellent cutting power of previous Keencut models. With an angled, easy-to-read measuring scale and flip-in/out measuring stops, you achieve fast, repeatable precision accuracy with every cut. The strong PVC-covered arms create a supportive non-scratch surface suited to cutting expensive museum or other coated glass.

With the Excalibur 6000, you can instantly swap from cutting mountboard, to glass, to MDF. All blades cut down the same line so that all materials are square and accurately cut to ensure a perfect frame fit.

The advanced design has a lighter construction, greater material protection, and a simple squaring procedure, as well as all the accuracy and safety features you expect from a Keencut machine.



Cutting mountboard



Cutting glass



Cutting MDF - Twin wheel head

Key features:

- Fast, repeatable precision accuracy
- Switches to cut mount board, hardboard, glass or acrylic in seconds
- Protects coated glass surfaces
- Cuts with no dust
- Easy-to-read measuring scale
- Easy cutting motion reduces fatigue
- All cutting tools as standard
- Safety by design
- Unique pressure-sensitive clamp
- Wall mounted or optional free standing kit
- 5 year Keencut guarantee

Dimensions

Cut length	160cm
Machine height	226 - 264cm
Machine width	213cm
Packed weight	69½kg

EXC6000 Keencut Excalibur 6000 Each



SteelTrak

Cutting and finishing the toughest materials in a single action.

The SteelTrak gives you the flexibility to cut anything from PVC foamboard to steel composite panels.

It is more accurate, consistent, and reliable than any other machine on the market. In a single movement, you can slice easily through the toughest materials to leave a smooth edge with no need for extra finishing.

Its unique features will speed up your production, whilst guaranteeing a perfect cut every time. The SteelTrak is the essential tool for a high-volume production unit.



Key features:

- Turn and lock ready mounted tools
- Universal four tool cutting head with auto blade disengagement
- Low friction ball bearings on a steel track for ultra-smooth operation
- 20 year replacement guarantee on all sliding bearings
- All blades cut on the same line and cut and finish large sheet materials in one pass
- Full length extra grip clamping system
- Quick set production stops
- Telescopic legs
- Perma-lock squaring

Optional accessories:

- V groove tool • Free standing kit
- Replacement blades for V groove attachment
- Glass cutting kit • Aluminium cutting head
- Squaring arm extension

STEELTRAK165	SteelTrak 165cm cut	Each
STEELTRAK210	SteelTrak 210cm cut	Each
STEELTRAK250	SteelTrak 250cm cut	Each



Dimensions

STEELTRAK165

Cut length	165cm
Machine height	226 - 264cm
Machine width	213cm
Packed weight	75kg

STEELTRAK210

Cut length	210cm
Machine height	271 - 309cm
Machine width	213cm
Packed weight	94kg

STEELTRAK250

Cut length	165cm
Machine height	226 - 264cm
Machine width	213cm
Packed weight	75kg



Sabre Series 2

The versatile cutter designed for safety and accuracy.

The Sabre Series 2 is a fully mobile all round cutter bar that will slice through 13mm thick foamboard or trim tissue paper gently.

The single tool head offers a choice of three blade holders which can be switched safely and quickly to suit different materials. Blade changing and depth adjustment are simple and completed without the use of additional tools.

Its strong base provides a stable cutting platform and it will sit directly on a bench or can be mounted on an optional stand which can be fitted with a waste catcher and roll feed.



Key features:

- Vertical cutting action
- Graphik blade¹, rotary blade² and medium duty blade³ holders included as standard
- Blade depth adjuster
- Blade clamp
- Integral baseplate and hinge arms
- Silicone grip strips in the base and underside of the cutter bar

Optional accessories:

- Extended squaring arm
- Hot knife holder
- Stand and stand pack
- Extended measuring arm



Dimensions

	SABRE100	SABRE150	SABRE200	SABRE250	SABRE300
Cut length	100cm	150cm	200cm	250cm	300cm
Machine width	118cm	168cm	218cm	268cm	318cm
Machine depth	33cm	33cm	33cm	33cm	33cm
Packed weight	20kg	27kg	34kg	41kg	48kg

SABRE100	Sabre Series 2 100cm cut	Each
SABRE150	Sabre Series 2 150cm cut	Each
SABRE200	Sabre Series 2 200cm cut	Each
SABRE250	Sabre Series 2 250cm cut	Each
SABRE300	Sabre Series 2 300cm cut	Each



Simplex

The lightweight and robust portable cutter.

The Simplex is very adaptable providing safe and accurate cutting of a wide variety of materials up to 3.1 metres wide. It uses utility knife blades and features blade depth adjustment as standard. The utility blades will cut to a depth of 10mm.

The Simplex is guaranteed to cut within 1.0mm of a straight line for the whole length of the cutter. The soft silicone cord on the underside grips and protects materials whilst preventing any movement during use. The Simplex is calibrated for immediate 'out of the box' accuracy and is designed to remain accurate with only minimal maintenance.



Key features:

- Fully portable, lightweight and robust
- Ergonomic cutting head
- Accepts standard off the shelf medium duty utility blades
- Unequalled blade control and effortless cutting
- Spring loaded cutting head so blade instantly retracts when not in use
- Patented bearing and slide system
- 20 year guarantee on all bearings
- 5 year guarantee

Optional accessories:

- Fabric tool cutter



Fabric tool cutter

SIMPLEX110	Keencut Simplex 110cm cut	Each
SIMPLEX160	Keencut Simplex 160cm cut	Each
SIMPLEX210	Keencut Simplex 210cm cut	Each
SIMPLEX260	Keencut Simplex 260cm cut	Each
SIMPLEX310	Keencut Simplex 310cm cut	Each

Dimensions

	SIMPLEX110	SIMPLEX160	SIMPLEX210	SIMPLEX260	SIMPLEX310
Cut length	110cm	160cm	210cm	260cm	310cm
Machine width	127cm	177cm	227cm	227cm	327cm
Machine depth	11cm	11cm	11cm	11cm	11cm
Packed weight	4kg	6kg	7kg	21kg	26kg



Evolution3™ FreeHand

Evolution3 accuracy in a portable cutter.

The Evolution3 FreeHand has been designed for those who require the high precision accuracy and superior cutting quality of the Evolution3 range but in a more flexible format.

It is perfect for a workshop where the cutter bar is required to move between workbenches.

Evolution3 FreeHand gives you all the benefits of the QuikSwap cutting tools, sightline strip accuracy and anti-sag design in a portable cutter.



Key features:

- The lightest model in the E3 range
- Fully portable
- QuickSwap Double Graphik toolhead comes as standard
- 2 silicone strips on the underside prevent any slipping when in use
- Cuts many different materials including delicate fabrics
- 5 sizes available

Optional tool heads:

- 1 - Evolution3 fabric tool head
- 2 - Evolution3 rocker tool head
- 3 - Evolution3 creaser tool head



EVOL3FH110	Evolution 3 - FreeHand 1.1m	Each
EVOL3FH160	Evolution 3 - FreeHand 1.6m	Each
EVOL3FH210	Evolution 3 - FreeHand 2.1m	Each
EVOL3FH260	Evolution 3 - FreeHand 2.6m	Each
EVOL3FH310	Evolution 3 - FreeHand 3.1m	Each

Dimensions

	EVOL3FH110	EVOL3FH160	EVOL3FH210	EVOL3FH260	EVOL3FH310
Cut length	110cm	160cm	210cm	260cm	310cm
Machine width	142cm	192cm	242cm	292cm	342cm
Machine depth	15½cm	15½cm	15½cm	15½cm	15½cm
Packed weight	22kg	28kg	34kg	40kg	46kg



Evolution3™ SmartFold

The ultimate cutting tool for the busy production environment.

The Evolution3 SmartFold includes all the superior features of the Evolution3 range with the addition of an integral cutting strip for textiles and fragile materials. It can be folded down to clear the bench and then returned in seconds to be immediately ready for use.

Keencut's unique Lift-and-Hover (patent pending) technology enables fast single-handed, and accurate alignment of all material, irrespective of thickness. Lower the clamping bar until it hovers just above the material surface with zero sag, even on the longest 3.6m length cutter, then use the sightline strip to see where the cut will be made, and finally, fully engage the clamp and cut – it's so simple.



Key features:

- Single-handed, fast accurate alignment
- Fits on any bench or the purpose built Keencut Evolution-2 bench
- QuickSwap Double Graphik toolhead comes as standard
- 2 silicone strips on the underside prevent any slipping when in use
- Cuts many different materials including delicate fabrics
- 6 sizes available

Optional tool heads:

- 1 - Evolution3 fabric tool head
- 2 - Evolution3 rocker tool head
- 3 - Evolution3 creaser tool head



EVOL3SF110	Evolution 3 - SmartFold 1.1m	Each
EVOL3SF160	Evolution 3 - SmartFold 1.6m	Each
EVOL3SF210	Evolution 3 - SmartFold 2.1m	Each
EVOL3SF260	Evolution 3 - SmartFold 2.6m	Each
EVOL3SF310	Evolution 3 - SmartFold 3.1m	Each
EVOL3SF360	Evolution 3 - SmartFold 3.6m*	Each

*Delivery surcharge applies to this item

Dimensions

	EVOL3SF110	EVOL3SF160	EVOL3SF210	EVOL3SF260	EVOL3SF310	EVOL3SF360
Cut length	110cm	160cm	210cm	260cm	310cm	360cm
Machine width	148cm	198cm	248cm	298cm	348cm	398cm
Machine depth	27cm	27cm	27cm	27cm	27cm	15½cm
Packed weight	30kg	37½kg	46½kg	53½kg	63kg	71½kg



Evolution3™ BenchTop

Single handed, fast and accurate cutting.

Permanently installed for immediate use, the Evolution3 BenchTop is perfect for a busy studio or high use production environment.

The unique Lift-and-Hover (patent pending) technology enables single-handed, fast and accurate alignment of all material, irrespective of thickness. Lower the clamping bar and it hovers just above the material surface with zero sag, even on the full length 3.6m cutter. Use the sightline strip to see where the cut will be made, then fully engage the clamp. You can rapidly change the QuikSwap heads to provide general cutting, creasing or fabric cutting with guaranteed ultra-high 0.2mm precision accuracy with every cut.



Key features:

- Single-handed, fast accurate alignment
- Fits on any bench or the purpose built Keencut Evolution-2 bench
- QuickSwap Double Graphik toolhead comes as standard
- Cuts many different materials including delicate fabrics
- 6 sizes available

Optional tool heads:

- 1 - Evolution3 fabric tool head
- 2 - Evolution3 rocker tool head
- 3 - Evolution3 creaser tool head



EVOL3BT110	Evolution 3 - BenchTop 1.1m	Each
EVOL3BT160	Evolution 3 - BenchTop 1.6m	Each
EVOL3BT210	Evolution 3 - BenchTop 2.1m	Each
EVOL3BT260	Evolution 3 - BenchTop 2.6m	Each
EVOL3BT310	Evolution 3 - BenchTop 3.1m	Each
EVOL3BT360	Evolution 3 - BenchTop 3.6m*	Each

*Delivery surcharge applies to this item

Dimensions

	EVOL3BT110	EVOL3BT160	EVOL3BT210	EVOL3BT260	EVOL3BT310	EVOL3BT310
Cut length	110cm	160cm	210cm	260cm	310cm	360cm
Machine width	148cm	198cm	248cm	298cm	348cm	398cm
Machine depth	20½cm	20½cm	20½cm	20½cm	20½cm	20½cm
Packed weight	27kg	34½kg	42kg	50kg	56kg	62½kg



SmartFold Bench

Specifically designed for the Evolution3 SmartFold.

The cutter bar is fixed to the bench by an aluminium extrusion which is part of the actual bench making for an extremely strong and stable platform. Available for all sizes of the Evolution3 SmartFold.

Keencut benches use the unique patented Proteus construction method; providing a strong and stable workbench that remains stable over time. The Proteus benches are easy to assemble with concealed fittings which gives a professional finish.

Key features:

- Strong and solid foundation required for precise accurate cutting
- Available for all sizes of the Evolution 3 SmartFold and BenchTop cutters
- Adjustable feet for levelling on uneven surfaces
- The cantilever kit is included as standard which gives the option of extending the width of the worktop
- Worktop not included



Dimensions

Machine Type	EVOL3SF-110	EVOL3SF-160	EVOL3SF-210	EVOL3SF-260	EVOL3SF-310	EVOL3SF-360
Bench width	140cm	190cm	240cm	290cm	340cm	390cm
Bench depth no cantilever	133cm	133cm	133cm	133cm	133cm	133cm
Bench depth with cantilever	163cm	163cm	163cm	163cm	163cm	163cm
Bench height	90cm	90cm	90cm	90cm	90cm	90cm
Packed weight	29kg	41½kg	46kg	50kg	63kg	68kg



BenchTop Bench

Specifically designed for the Evolution3 BenchTop.

The perfectly flat surface and reassuring stability ensures an ideal environment for precise cutting.

Keencut benches use the unique patented Proteus construction method; providing a strong and stable workbench that remains stable over time. The Proteus benches are easy to assemble with concealed fittings which gives a professional finish.



Key features:

- Strong and solid foundation required for precise accurate cutting
- Available for all sizes of the Evolution 3 SmartFold and BenchTop cutters
- Adjustable feet for levelling on uneven surfaces
- The cantilever kit is included as standard which gives the option of extending the width of the worktop
- Worktop not included

Dimensions

Machine Type	EVOL3BT-110	EVOL3BT-160	EVOL3BT-210	EVOL3BT-260	EVOL3BT-310	EVOL3BT-360
Bench width	148cm	198cm	248cm	298cm	348cm	398cm
Bench depth no cantilever	122cm	122cm	122cm	122cm	122cm	122cm
Bench depth with cantilever	152.5cm	152.5cm	152.5cm	152.5cm	152.5cm	152.5cm
Bench height	90cm	90cm	90cm	90cm	90cm	90cm
Packed weight	23kg	32kg	35kg	37kg	47kg	50kg



Blades and Cutter



TECHD

Double-sided mount cutter blades. Ideal for standard picture framing applications when used with the Ultimat Gold and Ultimat Futura.

	Per
TECHD (0.012")	100
TECHD2 (0.015")	100



TECHS

Single-sided mount cutter blades. For bevel cutting white core and conservation mat board up to 3mm with the Ultimat Gold and Futura.

	Per
TECHS (0.012")	100
TECHS2 (0.015")	100



K080

For general purpose and specialised applications Used in the majority of Keencut Cutters.

	Per
K080 (0.017")	100



KEEN032

Graphik blades for use in the vertical action Graphik blade holder.

	Per
KEEN032	100



STVGB

V Groove Blades for use with SteelTraK Attachment.

	Per
STVGB	5



GCW3

Glass wheel assembly for Excalibur 5000.

GCW3	Each
------	------

KEENCUT Accessories



SteelTrak V Groove Attachment

Easiest and most economical way to construct a sign-tray.



SteelTrak Alu Cutting Head

Tool for cutting aluminium sheet material up to 1mm thick.



SteelTrak Glass Cutting Kit

For all SteelTrak sizes and models.

Kit includes

- Glass cutting ramp x 1
- Stainless steel squaring arm protection strips x 2
- Glass cutting block to affix to SteelTrak x 1
- Glass cutting wheels x 2
- Fixing screw x 1
- 1.5mm Allen key x 1

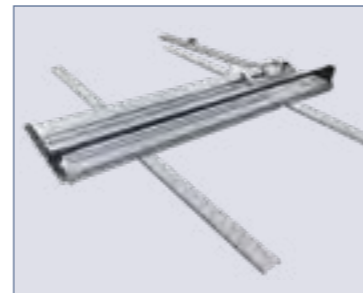

Support Arms - Ultimat Futura

Adds support and prevents sag when cutting large boards.



Textile Cutter - Simplex only

For delicate materials that can't be cut by conventional methods.



Hot Knife Holder - HSGM Cutter

For cutting and sealing synthetic fabrics, belting, webbing and more.



Hot Knife Holder - AZ Cutter

For cutting and sealing synthetic fabrics, belting, webbing and more.

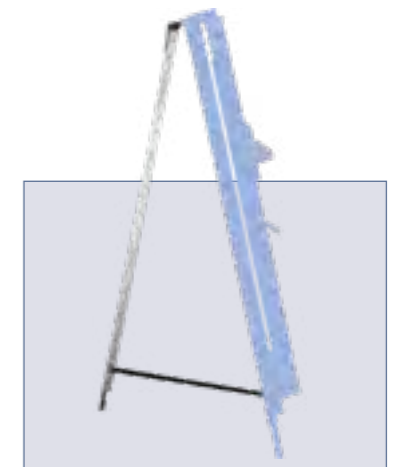

Free Standing Kit

For SteelTrak and Excalibur 5000. Ideal when wall space is limited.



Medium Duty Blade Holder

Sable Series 2 - Uses standard off the shelf utility blades.



Graphik Blade Holder

Sable Series 2 - Specially crafted knife edge for tougher materials.



Rotary Blade Holder

Sable Series 2 - Cuts textiles and is ideal for trimming thin strips.

F-2200 Mount Cutter

Professional level mount board cutter for creating bevels and V-grooves.

The F-2200 creates bevels and V-grooves as decorative features and finishes in mount board up to 4-ply. It has a dual cutting feature for mount board specialty cutting, or a 90° cutting feature for sizing mount board or cutting foam board up to 13mm.

The machine base is made from anodized aluminium which will not warp or flex during cutting.

Ball bearings glide the cutting head along the hardened aluminium bar clamp for cutting ease.



Key features:

- Cuts 8-ply mat, gator and foam board
- Maximum cutting thickness - 13mm
- Three different blades available .012", .015" and 90°
- Cutting head sight gauge for precise control of over/under cuts
- Removable blade magazines for quick changes and cutting depth adjustments
- Two adjustable Delrin bushings fit the head firmly to the shaft
- A pin locator and mat gauge system provide accurate and repeatable settings

Optional accessory

- Interlocking base plate extension
Includes mat guide slide with scale and upper stop slide with scale

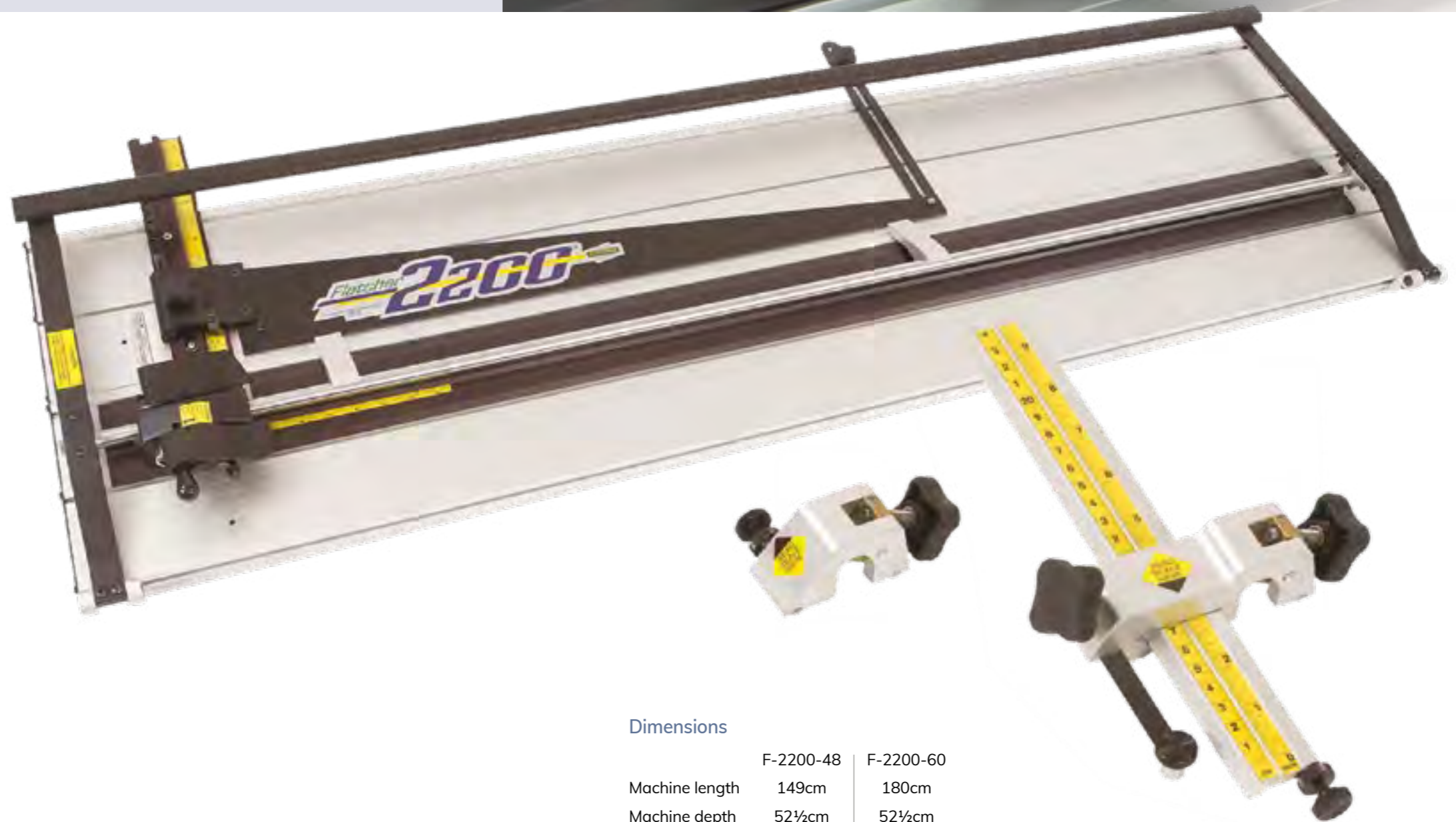

		Per
F-2200-48	Fletcher Mount Cutter	Each
F-2200-60	60" Fletcher Mount Cutter	Each
BF2100	0.12" Blades for F-2200	100
BF2101	0.12" Blades for F-2200	100
BF1100	Blades for F-1100 Oval Cutter	100

Dimensions

	F-2200-48	F-2200-60
Machine length	149cm	180cm
Machine depth	52½cm	52½cm

F-3100 Board and Glass Cutter

A versatile wall cutter designed with an interchangeable cutting head platform.

The F-3100 uses multiple cutting blades, scoring tips and cutting wheel holders to cut and score a large variety of materials. It can handle material sheets up to 63" high and features an acrylic breakout function.

The vertical bar rails are fabricated from DOM steel which is hard chrome plated and polished resulting in a smoother gliding action for consistent performance. The rails do not flex during the cutting process which ensures accurate cutting over the entire substrate height.



Key features:

- Interchangeable cutting heads
- Cuts cleanly, debris free, no secondary processing
- Cuts mount board and foam board up to 12.7mm thick
Hardboard, MDF, up to 2.4mm thick
Scores glass and plastic
- Lever clamping system prevents material buckling and moving during cutting
- Cutting head rides on high tensile steel which is hard chrome plated and polished
- Mounts on wall or freestanding



Board Pillar Post

For cutting gatorboard, foamboard, matboard up to 12mm thick. 10 Fletcher utility blades included with machine.



Glass Pillar Post

For scoring glass up to 6mm thick. Contains a Fletcher 120° hardened steel wheel. 10 replacement blades included with machine.



Plastics Pillar Post

For scoring plastics, acrylics and fracture sensitive materials up to 6mm thick. 10 replacement blades included with machine.



Hardboard Pillar Post

For scoring hardboard up to 3mm thick. Uses 2 steel wheels that cut from the front & back. 1 wheel set included with machine.

		Per
F-3100	Fletcher Board Cutter	Each
F-3100S	Measuring Stop	Each
BF3100	Blades for F-3100	100
GCW3100	Glass Wheels	Each
GCW3101	Steel Glass Wheels	10
HW3100	Hardboard Wheel Set	Each
PCB3100	Plastic Cutting Blades	10



Dimensions

Cut capacity	160cm
Height	241cm
Width	203cm
Depth	43cm
Wall space	3.96m ²
Weight	41kg

BA3



BA4



BA5



Budget Range Silent Compressors

Budget range doesn't mean budget specification.

All models have an internally coated receiver to guard against corrosion, easy to view oil level sight glass, premium Condor pressure switch, 10 micron outlet filter and adjustable pressure regulator. - They are the ideal choice for where compressed air is needed silently!

BA3 Bambi Silent Compressor

- 24 litre capacity (single pot)
- 120 psi working pressure
- 50 ltr/min output
- Low noise levels
- Adjustable outlet pressure
- 3 year warranty on air receiver
- 1 year warranty on electrics
- Only suitable for very low use

BA3 24ltr Budget Range Silent Compressor Each

BA5 Bambi Silent Compressor

- 50 litre capacity (double pot)
- 120 psi working pressure
- 100 ltr/min output
- Low noise levels
- Adjustable outlet pressure
- 3 year warranty on air receiver
- 1 year warranty on electrics
- Suitable for mid range use

BA5 50ltr Budget Range Silent Compressor Each

BA4 Bambi Silent Compressor

- 24 litre capacity (double pot)
- 120 psi working pressure
- 100 ltr/min output
- Low noise levels
- Adjustable outlet pressure
- 3 year warranty on air receiver
- 1 year warranty on electrics
- Suitable for low to mid range use

BA4 24ltr Budget Range Silent Compressor Each

Optional extra for all models

- Wheel Kit



PLEASE NOTE All budget range compressors allow a small amount of oil into the air system! When choosing your tank size please allow enough capacity so as not to over work your compressor and shorten its life.

Oil Free Compressors

Designed with quality at the forefront.

With ultra-low noise, from only 54 dB(A) and 100% oil free operation, the PT compressors deliver a low maintenance solution to ultra-quiet oil free compressed air.

The motor cover provides user protection from the hotter parts of the compressor while ensuring perfect air circulation for optimum performance.

Anti-corrosion, internally coated receivers are fitted as standard. This prolongs the life of the receiver and ensures the air delivered is contamination free.



BA9 Bambi 50lt Oil Free Compressor

- 50 litre capacity
- Condor pressure switch
- 10 micron air filter
- Outlet pressure regulator
- Stainless steel braided pipework
- No oil level to check
- Ultra low noise levels

BA9 Bambi 50ltr Oil Free Ultra Low Noise Each

BA8 Bambi 24lt Oil Free Compressor

- 24 litre capacity
- Minimal maintenance
- No oil level to check
- Ultra low noise levels
- Compact design, suitable for tight spaces

BA8 Bambi 24ltr Oil Free Ultra Low Noise Each



Compressor Fittings

Compressor Oil

COMPOIL 1ltr Bambi Compressor Oil Each



Air Hose

- Supplied with 1/4" fittings
- Polyurethane
- Up to 125psi working pressure
- Ideal for use with air tools

HOSE2 1/4" Thermoplastic Air Hose Each



Hose Clips

AHC1 Air Hose Clips Each



Hose Tail Fitting

HTF1 Hose Tail Fitting Each



Quick Release Fittings

QR1 Quick Release Coupling Male Thread Each



QR2 Quick Release Coupling Female Thread Each



QR3 Quick Release Coupling Hose Tail Each



QR4 Quick Release Plug Male Thread Each



QR5 Quick Release Plug Female Thread Each



QR6 Quick Release Plug Hose Tail Each



'Y' Piece

YP1 1/4" Y Piece Female Thread Each



Dust Extractors

This range of dust extractors are industrial quality machines aimed at professionals who need constant use. Supplied with high filtration as standard.

Key features

- Quiet induction motors
- Can run up to 8 hours a day
- Transparent collection bag
- Wheels included for portability
- W791 and W992 come with superfine 2 micron filter
- W791 and W992 available as single or 3 phase
- W791 has 148ltr bag capacity
- W792 has 2 x 148ltr bag capacity
- W796 has 70 ltr bag capacity

		Per
W791	Dust Extractor 1500W (2hp)	Each
W792	Dust Extractor 2200W (3hp)	Each
W796	Dust Extractor 750W (1hp)	Each
100FLEX	100mm dia. Transparent Flexible Hose	Metre
100HC	Wire Type Hose Clamp for 100m Hose	Each



Hand Tools

Bostitch Air Staple Gun

- Ideal for holding in backs of pictures
- Low recoil
- Uses type 72 staples

		Per
K1	Air Operated Staple Gun	Each
K7	8mm Staples	10,000
K2	10mm Staples	10,000
K3	12mm Staples	10,000



Tacwise Air Staple Gun

Tough, fast and reliable. All metal magazine system, extremely quick to reload.

		Per
RAP1	Tacwise Air Gun Standard	Each
RAP2	Tacwise Air Gun Narrow	Each
RAP3	Tacwise Standard 5mm Staples	20000
RAP4	Tacwise Standard 6mm Staples	20000
RAP5	Tacwise Standard 8mm Staples	20000
RAP6	Tacwise Standard 10mm Staples	20000
RAP7	Tacwise Standard 12mm Staples	20000
RAP8	Tacwise Narrow 10mm Staples	5000



Fletcher Fleximaster Gun

- Easy-to-load magazine holds 170 flexible points
- Fires one point at a time without double feeding or jamming
- Tension adjustment to adjust firing power for the density of the wood
- Rear stabilizer stands Fleximaster upright

		Per
FP7	Fletcher Fleximaster Gun (Manual)	Each
FP8	Fletcher Flexipoints (3700) Black	Box
FP8/10K	Fletcher Flexipoints (10,000)	Box



Fletcher Multimaster Gun

- Easy-to-load magazine holds 167 multipoints per stack
- Tension adjustment to adjust firing power for the density of the wood
- Rear stabilizer stands Fleximaster upright
- Twin barb design with 50% more rigidity increases holding power
- Excellent fastener for quick and secure assembly of layered (stacked) and liner mouldings

		Per
FM800	Fletcher Multimaster Gun	Each
MP975	Fletcher Multipoints	3000



Fletcher Framemaster Gun

- Professional quality lightweight point driver
- Easy-to-load magazine holds 100 points
- Fires one point at a time without double feeding or jamming
- Tension adjustment to adjust firing power for the density of the wood
- Reversible head takes both Framers (long) points and Glaziers (short) points
- Rear stabilizer stands Framemaster upright
- Single-shot version (inserts one point at a time)

		Per
FS500	Fletcher Framemaster Gun	Each
FP950	Fletcher Framers Points	3000
GP980	Fletcher Glaziers Points	5000

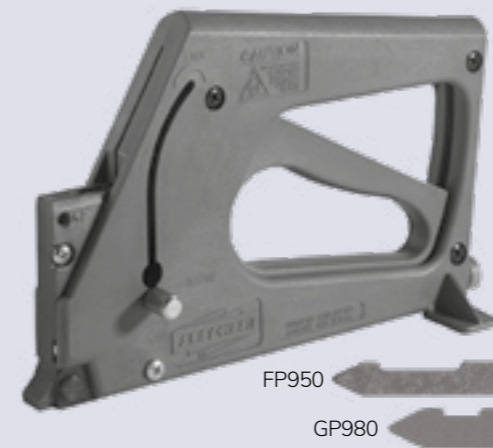

Fletcher Pushmate

- The perfect choice for inserting Fletcher push points and triangle points into frames
- Rubberized raised grip provides added comfort and helps prevent damage to the mount and other backing materials

		Per
F-515	Fletcher Pushmate	Each
F-711	Fletcher Push Points	50
F-712	Fletcher Push Points Bulk 25lb Box	Box



Bessey Band Clamp

- Heavy duty band clamp
- Even pressure on mitre joints
- Crank handle can be relocated for right and left-handed users
- 25mm x 7mt band

BESSEY Bessey Band Clamp Each



Cutting Mats

Our cutting mats come in a range of sizes and are designed for light trimming and cutting. They have a basic self-healing surface and grid lines on both sides to aid trimming.

CM1	Cutting Mat 2000mm x 1000mm	Each
CM2	Cutting Mat A0 1189mm x 841mm	Each
CM3	Cutting Mat A1 841mm x 594mm	Each
CM4	Cutting Mat A2 594mm x 420mm	Each
CM5	Cutting Mat A3 420mm x 297mm	Each

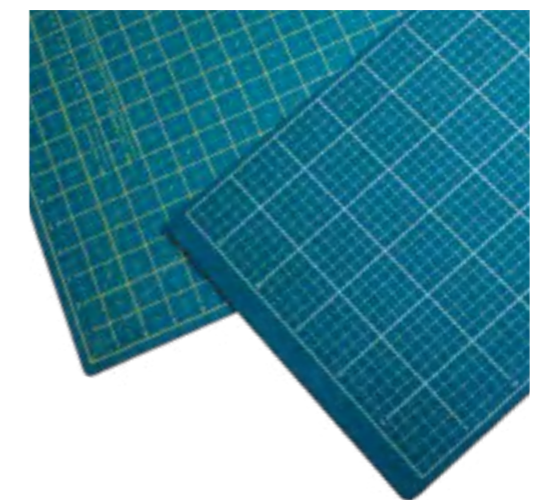

Fine Fabric T Tag Gun

Ideal for fixing fabric and small items to mountboard and foamboard. It is fast to use and the tags are easy to remove. They are almost invisible and make a very small hole.

		Per
FFTG	Fine Fabric T Tag Gun	Each
FFTG1	Spare Needles For T Tag Gun (x5)	Pack
FFTG2	T Tags 5mm White (2,000)	Pack



Glue Gun

A step up from the hobby version. This well balanced semi professional hot melt glue gun has maximum control and an easier output flow of glue. It will bond almost anything in less than 2 minutes.

		Per
GGUN40	40 Watt Glue Gun	Each
GLUE2	Hot Melt Glue Sticks 300mm	16



Heavy Duty Staple Gun

Expert quality, heavy-duty gun with adjustable power control. Ideal for stretching canvas or upholstery work.

It uses 6-14mm ESG staples (see below) and is supplied with 125 x 8mm and 125 x 12mm staples and staple remover

HSG1	Heavy Duty Staple Gun	Each
------	-----------------------	------



Staples

		Per
ESG2	6mm Staples	1000
ESG3	8mm Staples	1000
ESG4	10mm Staples	1000
ESG5	12mm Staples	1000
ESG6	14mm Staples	1000



Roller

These high quality rollers are ideal for use with self-adhesive boards. They have a soft rubber surface and are made from durable polypropylene with self-lubricating nylon bearings, aluminium core and a continuous steel shaft.

ROLLER	150mm (6") Soft Rubber Roller	Each
--------	-------------------------------	------



Safety Air Blow Gun - with nozzle

- Plastic body
- Conforms to OSHA standard
- Extension nozzle for difficult to reach places

AG2	Safety Air Blow Gun with Nozzle	Each
AG3	Blow Gun With 10" Nozzle	Each



Shrink Wrap Film

- PVC high quality shrink wrap film
- 600 metres per roll • Centre folded • 19µ thick

		Per		Per	
SU2	350mm wide	Roll	SU7	500mm wide	Roll
SU3	400mm wide	Roll	SU5	550mm wide	Roll
SU4	450mm wide	Roll			



Keencut Straight Edge

A superb aluminium cutting edge and safety ruler. It has two silicone rubber strips on the base that prevent slippage. The hardened steel rod embedded in the cutting edge prevents your blade cutting gouges in the ruler and the high safety guard rail stops the blade riding up onto fingers. It has a generous flat surface for holding the ruler in place.

MS45	45cm Keencut Safety Edge	Each
MS60	60cm Keencut Safety Edge	Each
MS75	75cm Keencut Safety Edge	Each
MS90	90cm Keencut Safety Edge	Each
MS105	105cm Keencut Safety Edge	Each
MS120	120cm Keencut Safety Edge	Each
MS135	135cm Keencut Safety Edge	Each
MS150	150cm Keencut Safety Edge	Each
MS180	180cm Keencut Safety Edge	Each





National Training

As part of Wessex Pictures ongoing investment in future businesses, we run the award winning **ORIGIN FRAMING SCHOOL** from our premises in **Leatherhead**.

These are a series of professional courses with a view to training:

- people setting up their own framing business
- framing staff for existing workshops
- professional framers wishing to expand their business by learning new skills.

Classrooms are equipped with a variety of machines to familiarise students at different levels and to help prospective buyers decide which models best suit their needs.

Courses are run by a team of professional framers or technicians who initiate with a lecture and follow up with practical demonstrations and supervision.

- Courses run Monday to Friday from 9.30am - 5.00pm
- Refreshments provided (morning and afternoon)
- Lunch is provided at no extra charge

Positions on each course are limited to 6-8 students. A £125 deposit is required to reserve a place. The balance is due three weeks before the course starts. In the event of a cancellation the deposit is only refunded if three weeks notice is given in writing.

Each student completing a full five-day course will be awarded a certificate of attendance.

Good framers get qualified

The National Training Centre is a testing centre for the Fine Art Trade Guild's Commended Framer scheme. We run a 'pre-test course' so framers can familiarise themselves with different machines and run through the format of the test.



We also hold special presentation days, where representatives of the various machinery companies we deal with demonstrate their products.

Tailor made courses can also be arranged for any framer wishing to study a particular subject.

Prices on application for tailor made courses.

Wessex Pictures Commercial Framing Course has been accredited by the Fine Art Trade Guild.



Awarded in recognition of quality, content and high standards of professionalism in which the courses are run.

Dry Mounting



For all of your dry mounting and laminating requirements, the Hot Press™ range of equipment and materials are an essential for any modern workshop.

Dry Mounting

Pressure Sensitive Mounting Films

Our comprehensive range of pressure sensitive or “cold” mounting films are ideal for all types of mounting projects - from board and print mounting to specialist applications, such as face mounting, acrylic and window graphics.

All of our films use the highest quality adhesives, carriers and release liners so you can always be assured of the best results.

As with all adhesive products we strongly recommend testing before use.



HOT PRESS

Twintak Double Sided Mount Film

This is our most popular pressure sensitive film. It works well with all kinds of “cold” laminators and can even be applied by hand for specialist jobs.

This film is suitable for plain paper and posters, inkjet and photographic media. Due to its strength and flexibility, it works well with plastic based media and textured art papers. It also works with mounting substrates, from white display and foam centred boards to rigid plastic boards and MDF.

The product is formed from a clear central carrier film which is coated on both sides with a very strong adhesive. Each adhesive layer is protected by a grid marked release liner. The two separate release liners mean that this adhesive can be rolled out on the work bench and simply cut to the correct size.

		Per
PSA47-25082	650mm x 25m (25.5" x 82')	Roll
PSA47-25328	650mm x 100m (25.5" x 328')	Roll
PSA47-41082	1040mm x 25m (41" x 82')	Roll
PSA47-51082	1300mm x 25m (51" x 82')	Roll

Facemount UV Transparency Mount Film

The more established and superior quality optically clear mounting film. For wall art and acrylic blocks, this film offers a much better colour rendition and is truly invisible even when viewed close up.

Facemount UV is the choice of photographers, framers, digital artists and photo labs who want to produce the highest quality products.

The central layer of this film is made from polyester which gives a much higher clarity than polypropylene or PVC films.

		Per
PSF25082	650mm x 25m (25.5" x 82')	Roll
PSF41164	1040mm x 50m (41" x 164')	Roll

Mediatac Self Wound Mounting Film - Standard

Self wound mounting films have just one release liner, which is non-stick on both sides. As the roll is unwound the adhesive layer is exposed, so these films cannot be used for cut sheet applications.

The full width of the roll will always be used as the film passes through the laminator, making it more suited to volume jobs.

Our standard variant is a general purpose film that's suitable for most kinds of artwork, from plain paper and posters to inkjet and photographic media. It works well with all kinds of mounting substrates, from white display board and foam centred boards to MDF and rigid plastic boards.

		Per
PSA26-25164	650mm x 50m (25.5" x 82')	Roll
PSA26-41164	1040mm x 50m (41" x 164')	Roll
PSA26-51164	1300mm x 50m (51" x 164')	Roll

Ultratac Self Wound Mounting Film - Ultra

Developed for more challenging applications, where the standard product may struggle.

Mounting substrates such as corex or aluminium are notoriously difficult to get a strong bond to, and this film will provide a better result. Similarly, when trying to wrap graphics around the edge of thicker substrates such as MDF, the extra adhesion that this film provides will do the job.

		Per
PSA26P-41164	1040mm x 50m (41" x 164')	Roll

Pressure Sensitive Laminating Film

This Hot Press™ pressure sensitive or “cold” lamination film is designed for use with the JetMounter™ and other quality roller laminators.

The film works well at room temperature and provides superior protection from abrasion, moisture and pollutants. It contains UV stabilisers and absorbers to inhibit fading and discolouration from sunlight.



Photo UV Crystaltext™ 90µ

Similar to Sand Texture and Sheentex, this film has a tiny diamond faceted surface texture that scatters light to give a deep lustrous finish to print surfaces. It's reminiscent of our very popular gloss lustre heatseal finish.

Photo UV Crystaltext™ is especially well suited to photographic style work.

Per
PSCR25082 650mm x 25m (25.5" x 82') Roll



HOT PRESS

4 reasons you should be using the No.1 product

- 1 Hot Press™ materials are simply the best product you can buy.
- 2 Hot Press™ offer the widest range of mounting and laminating supplies.
- 3 With the best prices available, why risk your reputation for anything less?
- 4 You will receive full technical support from Wessex Pictures.



Basic Dry Mounting Considerations

Dry mounting is the process of bonding an image to a mounting board. It may be simple, but there are important factors to consider...

Firstly

Consider the type of artwork you want to mount.

- How will the artwork react to heat?
- Does the artwork require pre-drying to remove excess moisture?
- Is the artwork clean and free from dust / dirt / stickers or tape?
- Is the artwork porous?
- Has the artwork been produced in a medium that may shift - eg. pastels?

All of these points should be considered before proceeding. With experience, it will become second nature.

Secondly

Determine what type of board is compatible with your artwork.

- What is the optimum thickness?
- Is quality or price the primary objective?
- Will the board need to be pre-dried to remove excess moisture?
- Would smooth board benefit the artwork?
- Does the board need to be coloured or textured?
- Is the board porous?

If you're unsure how the item being mounted will react to heat, always test a small piece of the material first.

Based on these conclusions, you can identify the best adhesive for your combination of artwork and board.

Please consult individual product descriptions and recommendations to arrive at the best match, or call us for more help.



HOT PRESS

Heated Glass Vacuum Presses

The Hot Press™ represents the most convenient and efficient way of hot mounting in modern framing. Capable of handling a wide range of materials from white display board, foam centred board and MDF to photographs, art prints, inkjet canvases and delicate fabrics.

Key features:

- 2 sizes available based on common board and graphics sizes
- Rigid construction for consistently good levels of vacuum
- No feet adjustment or spirit level required to balance the machine
- Transparent top panel to view work during procedures
- Gas struts support the lid
- Generous opening height of the lid
- Heavy duty rubber diaphragm bed
- Power for the dedicated vacuum pump is supplied directly from the press
- Airline connections between the press and pump are simple push/pull fittings
- Easy to read vacuum gauge
- CE approved - features safety cut outs
- Custom made press stands available
- User manual and training DVD

Hot Press™ Heated Glass Vacuum Press

HGP260 35" x 47" Hot Press Each

HGP360 43" x 67" Hot Press Each



Timing System

The Hot Press™ comes with a built-in programmable process timer. When the timing cycle has completed the vacuum pump will switch off, the atmospheric pressure will return to the press and the timer will reset for the next project.

When processing large volumes of work, the programmable timer can be set to the minimum time required for each batch of work, maximising productivity.

The timer has two different modes of operation: the auto setting allows for timed operation on repetitive jobs, whilst the manual setting allows the flexibility to set the machine running whilst you do other work. In this mode it will keep running until you return to the job.

Pressure System

The Hot Press™ typically delivers 14lbs of pressure per square inch, although the pressure may need reducing for certain jobs. This can be done by use of the pressure control valve, which fine tunes the pressure to your exact needs.

Hot Presses are supplied with their own dedicated vacuum pump. These units require no oiling, but they will collect moisture from damp artwork and boards. The moisture is collected in a moisture trap flask, which should be emptied periodically.

The variable pressure control ensures the right pressure is set for each job and minimises even heavy creases and wrinkles, whilst ensuring delicate items such as foam board and embossed prints are not crushed.

Heating System

The heart of the Hot Press™ is its unique heating system. Electricity is passed across a special conductive coating on the glass platen creating a very even heat. This heat is monitored several times every second and can be controlled to within 2°C.

This eliminates the need for 'press watching' and increases productivity in the workshop.

The adjustable temperature control allows all kinds of artwork to be dry mounted, even those that may be damaged by heat.

The controller allows temperatures from 0°C to 115°C to be set. Cold operation of the Hot Press™ means the machine can be used with wet adhesives for low value jobs.

Heat Activated Dry Mounting Tissues

Dry mounting tissues are the simplest of products to use and Hot Press™ make sure theirs set the highest standards in the print finishing industry.

Trimount Classic Dry Mounting Tissue

This premium grade dry mounting tissue is widely regarded as the industry standard for the permanent mounting of all types of flat artwork. It is especially popular among bespoke picture framers and photo processors, due to its superb "lay flat" properties. Trimount Classic™ is suitable for mounting posters, prints, photographs, inkjets, pastels, charcoals, colour copies, maps, charts, blue prints and plans.

Trimount Classic™ is compatible with a wide variety of substrates, including mount board, pulp boards, grey boards, foam centred boards, hardboard, MDF and white display board.

With a very wide activation temperature range, around 70°C to 115°C, it is ideal for a huge range of jobs. It has a very high grade adhesive which is impregnated into a porous pH neutral tissue. The tissue itself has excellent breathability, which allows air to escape from the various layers of your work.

		Per
TR25082	650mm x 25m (25.5" x 82')	Roll
TR25328	650mm x 100m (25.5" x 328')	Roll
TR41082	1040mm x 25m (41" x 82')	Roll
TR41164	1040mm x 50m (41" x 164')	Roll
TR41328	1040mm x 100m (41" x 328')	Roll
TR51082	1300mm x 25m (51" x 82')	Roll
TR51328	1300mm x 100m (51" x 328')	Roll

How to Pierce Dry Mount Film

It is not possible to pierce dry mount film during the manufacturing process. To pierce yourself, cut a piece to the desired size and place it on a cutting mat. Peel off one release paper to expose the bare adhesive layer (adhesive face up). Pierce with a piercing tool, covering the whole area with holes less than 1cm apart minimum - the more holes the better. Apply the pierced film to your artwork or board as required. The tiny pieces of plastic that are punched out will embed in the bottom paper layer, which is discarded later.

Heat Activated Mounting Films

For the more challenging or specialist applications. By choosing the right combination of adhesive and mounting board, the possibilities are unlimited.

Dry Mount Film

This is the most aggressive hot adhesive in the Hot Press™ range. Where Trimount Classic™ is cost effective and good for most jobs, Dry Mount Film Clear steps in when tougher challenges arise. When the adhesive is exposed at room temperature it has a low level of tackiness allowing the film to be positioned or tacked onto your artwork or mounting board. Dry Mount Film Clear is especially recommended for wood, MDF, plastics, textured art papers, canvases and other fabrics. It bonds well to both highly textured and very smooth surfaces.

The main difference between mounting tissues and films is that films do not "breathe". We recommend that this film is pierced with a piercing tool prior to use. The product is formed from a clear central carrier film which is coated on both sides with strong, heat activated adhesive. Each adhesive layer is protected by a grid marked release paper. The two separate release papers mean that this adhesive can be rolled out on the work bench and cut to the correct size for each mounting job.

		Per
MF25082	650mm x 25m (25.5" x 82')	Roll
MF41082	1040mm x 25m (41" x 82')	Roll
MF51082	1300mm x 25m (51" x 82')	Roll
MF51328	1300mm x 100m (51" x 328')	Roll

Flobond Acid Free Film

This is a "pure film" adhesive which melts as it is heated up and bonds as it cools and solidifies. Flobond Acid Free Film conforms well to uneven surfaces such as watercolour paper and fabrics, making it a versatile adhesive for most types of artwork and boards. It is widely believed that in most instances, this bond can be reversed by re-heating the adhesive, though we would strongly caution against this and offer no guarantee of success.

		Per
FL41082	1040mm x 25m (41" x 82')	Roll

Heat Activated Lamination Films



The Hot Press™ range of heat activated lamination films are often referred to as "heatseal" films. All our heatseal films are manufactured by Hot Press™ and contain UV inhibitors in both the film and the adhesive, stopping the films turning yellow or becoming brittle over time. This increases the fade resistance of the artwork underneath. Heatseal films are incredibly durable, easy to keep clean and come in a variety of finishes.

Artshield™ Mattex UV Satin

The overall finish of this film, once processed, is a stippled sheen effect. Often used to laminate posters and prints, as its subtle finish closely mimics that of the original printed piece. The satin matt finish reduces glare, but not contrast. This film can also be used as a satin top coating when prints are bonded to canvas or printed inkjet canvases are laminated.

		Per
MX25082PP	650mm x 25m (25.5" x 82')	Roll
MX41082PP	1040mm x 25m (41" x 82')	Roll
MX51082PP	1300mm x 25m (51" x 82')	Roll



Artshield™ Matt UV Full Matt

This film has a full matt finish that completely eliminates reflections. It also offers additional UV protection when used behind glass and is almost invisible. Full matt film is most often used where lighting is unpredictable and uncontrollable, such as exhibition halls and other public areas. The heat applied during processing gives the matt film a stippled and very scuff resistant surface. It can be used as a matt top coating when prints are bonded to canvas or printed inkjet canvases are laminated.

		Per
MT41082PP	1040mm x 25m (41" x 82')	Roll
MT41328PP	1040mm x 100m (41" x 328')	Roll
MT51082PP	1300mm x 25m (51" x 82')	Roll



Artshield™ Satinex UV Gloss

This film offers a very rich lustre finish, which is achieved by pressing the film against the surface of a foam blanket in the Hot Press™. The finish is very reminiscent of the lustre texture found on photographic papers. To change the finished texture, the artwork can be re-pressed against other textured or smooth surfaces to give an almost limitless choice of finishes from a single roll of film. It can also be used as a glossy top coating when prints are bonded to canvas or printed inkjet canvases are laminated.

		Per
SX41082PP	1040mm x 25m (41" x 82')	Roll
SX51082PP	1300mm x 25m (51" x 82')	Roll
SX51328PP	1300mm x 100m (51" x 328')	Roll



Ancillary Products for Hot Presses

To ensure that the hot mounting and laminating experience is both profitable and problem free we offer a complete range of ancillary products.

These products compliment and further improve the performance of hot presses.

Silicone Release Paper

This is a grid patterned paper, which is coated on one side with a standard quality silicone release agent. This economy grade product is used to cover exposed adhesives during pressing and can be used in all kinds of mounting and laminating heat presses.

		Per
GRP41082	1040mm x 25m (41" x 82')	Roll
GRP51082	1300mm x 25m (51" x 82')	Roll

Clear Silicone Release Film

This is a transparent film which is coated on both sides with a superior quality silicone release agent. This product is used to cover exposed adhesives during processing in a heat press. Though primarily designed for use with glass topped presses, this film can be used in any heated press. Its life expectancy is over ten times that of silicone release paper.

		Per
CRP41082	1040mm x 25m (41" x 82')	Roll
CRP50082	1270mm x 25m (50" x 82')	Roll

Vacufoam

This is a 5mm thick foam which is used to cover heatseal lamination films during pressing. This foam has been designed specifically for use in the Hot Press™. It is only suitable for use in vacuum press.

Please Note:

It is always advisable to pre-treat a new sheet of foam before using it on any work. All foam contains fire retardants and these activate when the foam is initially heated. New foam needs to be heat conditioned in the press under pressure for a period of time to 'cook' it in to a 'flat shape'. Failure to condition your foam can lead to invisible memory marks being embedded into the foam's surface. These can then show up on subsequent jobs as 'ghost' marks. If you would like more information on preventing this please feel free to contact us.

		Per
VACU01	2591mm x 1270mm (102" x 50")	Sheet

Tacking Iron

An electrically heated hand iron with a small precision tip that delivers a pre set amount of heat in a small area. Tacking irons are very useful for fixing dry mount tissue to the back of a print, or board, prior to activation in a press. It allows precision trimming and positioning of tissue and artwork on complex jobs.

		Per
TIRON	Tacking Iron	Each



Free Training for Dry Mounting

We invite you to attend one of our free training schools for an in-depth understanding of dry mounting techniques.



WHEN IMPACT
IS EVERYTHING

HOT PRESS

Display Products

Display Products



Put on a show with our great range of display products.
Show off what you can do!

Gallery Hanging System

Installing a gallery hanging system in your shop, gallery or studio can add a stylish look that is minimalist yet versatile and easy to change around.

This system minimises holes in the walls and may even prove to be the ideal solution for your own customers.

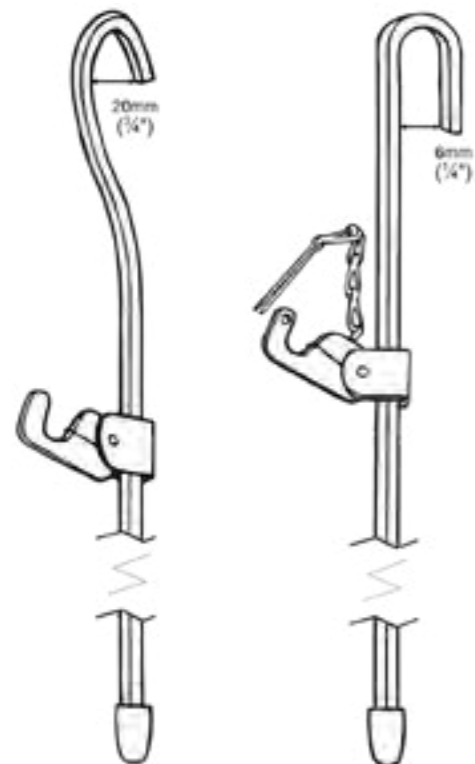
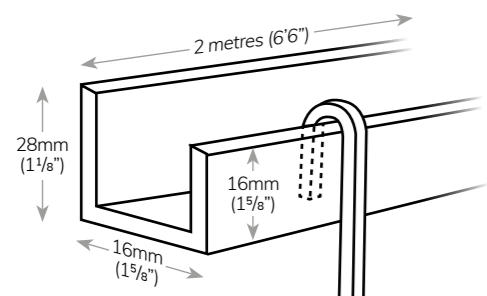

The system comprises of 3 component types...

Wall rail

This is the only item that actually screws to the wall and can be fixed to the desired height but bear in mind the length of rods you are going to use. The rail is made from aluminium and has no pre-drilled holes, allowing you to easily fix as many screws as you need to safely support the weight of work you intend to hang. The back of the rail stands taller than the front making it easier to fix screws into place.

Down rods

Sometimes referred to as 'suspenders', down rods are available in two lengths - 122cm (4') and 183cm (6'). They are also available in three top styles. 'U' tops hang vertically from the wall rail, whereas 'U' angled tops curve around the rail, allowing the rod to sit flusher to the wall. 'G' shaped rods are designed to be used with traditional wooden picture rails - found in older houses. The finish of the down rods is zinc metal. When hanging large or heavy pieces of art - consider using two down rods for extra stability.

Rod hooks

These have a collar that matches the profile of the down rods. They slide up and down the rod and lock into position by pulling the hook downwards. Depending on the style of display you are looking to create, you can use as many hooks as you need on one rail. Standard hooks are most commonly used, but for added safety and security a hook with a cotter pin is also available. Once the pin is inserted it stops the picture from being lifted off the hook.

ALR1	2 Metre Aluminium Rails	Each
GHSG4	4' 'G' Shaped Zinc Down Rods	Each
GHSG6	6' 'G' Shaped Zinc Down Rods	Each
GHSU4	4' 'U' Shaped Zinc Down Rods	Each
GHSU6	6' 'U' Shaped Zinc Down Rods	Each
SLH1	Self Locking Hooks Standard	Each
SLH2	Self Locking Hooks Security	Each



Steel Browser

This heavy duty print browser is designed as a permanent feature for your shop, studio or gallery. It is a strong steel construction which simply slots together. It comes with standard castors for mobility, though heavy duty castors are available as an option. Also available as an option is a wide angle version of the browser, allowing more sleeves to be used, whilst keeping each sleeve visible.

2125	To take 30" x 22" Sleeves	Each
2126	To take 40" x 30" Sleeves	Each
2127	To take 59" x 43" Sleeves	Each



Regular Sleeves

These sleeves can be used in print browser stands, or independently, to display flat artwork. They are constructed from anti-static and archivally stable polypropylene which is 130 microns thick. The edges have a tough black nylon binding and the sleeve contains a stiff 2mm polypropylene centre board. This allows work to be displayed on both sides of the sleeve - cleanly and neatly.

6501	24" x 19" Regular Sleeve	Each
6502	30" x 22" Regular Sleeve	Each
6500	40" x 30" Regular Sleeve	Each





Display Stand

This easel style display stand allows you to display up to four framed pieces neatly and safely.

The eight easel brackets slide up and down the steel pole and lock securely with a turn knob.

The complete unit stands 2 metres (6½') tall and has castors for ease of positioning.

Display stands for framed work are particularly useful to artists, framers and photographers who want to display their finished work at local trade shows, where wall space may be limited or non-existent.

It also works well in areas where there is more floor space than wall space, creating an attractive island feature.

The stand is finished in black and chrome.

STAND1 Display Stand Each



Tower Display

This sturdy, five sided tower is perfect for displaying moulding chevrons and smaller finished frames.

The tower display has a heavy five legged base and the tower revolves a full 360°.

This makes it the perfect solution for displaying moulding chevrons or smaller finished frames where floor or wall space is limited. When positioned in a corner all sides remain viewable.

The panels are covered in grey nylon fabric, which is Hook & Loop receptive. Other fabric colours are available to order.

Each face is 1.5m (59") x 30cm (12").

7126 12" 5 Sided Tower Display Each



Hook & Loop

Self-adhesive Hook & Loop has a variety of uses, but it is commonly used for the temporary attaching of graphic panels to nyloop style backdrops on display systems.

Another popular use is for displaying moulding chevrons within framing shops, galleries and photographic studios.

When used together, Hook & Loop can provide clean looking permanent displays on plain walls.

We offer a choice from small and larger dots to continuous strips. Dots are ideal for moulding chevrons and continuous strips are better for displaying graphics.

Hook & Loop is available on 25 metre rolls or by the metre. The approximate amount of dots you get per metre are:

13mm (1/2") dots = 66
22mm (3/4") dots = 40

4 handy tips for using Hook & Loop:

- 1 Where possible staple the Hook & Loop to your work for added durability.
- 2 Don't use too much, the bond is very strong and it can be hard to remove your work from a panel if too much is used.
- 3 For moulding chevrons, which may be taken on and off the panel regularly, three Hook dots will be more than adequate.
- 4 When using Hook & Loop together, it is common to use hook on your work and loop on the backing board or wall.

Hook		Per
HAL1	25mm Self Adhesive Hook	Metre
HAL3	13mm Self Adhesive Hook Dots	Metre
HAL4	22mm Self Adhesive Hook Dots	Metre
HAL2	25mm Self Adhesive Hook 25mtr roll	Roll
HAL5	13mm Self Adhes. Hook Dots (1500 dots)	Roll
HAL6	22mm Self Adhes. Hook Dots (1000 dots)	Roll
Loop		Per
HAL8	25mm Self Adhesive Loop	Metre
HAL7	25mm Self Adhesive Loop 25 mtr roll	Roll

Brushed Nylon (Nyloop)

This foam backed brushed nylon fabric is used for making your own custom display panels. It is 1370mm (54") wide, sold by the metre and available in two colours. Wrap it around the edge of your panels to increase the life of the panel. Fix the fabric to its backing board using neat PVA glue or a strong liquid contact adhesive and press firmly with a hand roller. WARNING - Spread the glue thinly as it will easily seep through the material.

To display your work on your finished panels, simply attach the hook part of 'hook & loop' strips or dots to your work and press against the display panel.

		Per
BN2	Blue Display Fabric	Metre
BN4	Grey Display Fabric	Metre



Colours are for guidance only actual colours may vary.

Fabrigrip® Twist On

Twist-On is a 500mm/19" strip with sharp spikes along the edge. The spikes make it easy to square and stretch most items. No adhesives or staples are required. It can be used on boards up to approximately 2.5mm thick and is easy to bend and cut to length. All off-cut pieces can be used. Packed in 10 strips of 500mm, 5m in total.

		Per
FAB1	Fabrigrip® Twist-on For Needlework 10 x 0.5m strips	Pack



Display your artwork in the best possible way with Specialist Glass

See pages 18 - 61 for our comprehensive range of specialist glass and acrylic glazing



wessexpictures.com



Framing Sports Items

The signed football shirt, the golf ball that scored the famous hole in one - mounting and framing these types of sports items is a very popular request from customers.

We offer a range of mouldings, clips and framing systems that will display and preserve these treasured items.



Sports Ball Clips

A simple, neat way to display sports balls. All of the ball clips are carefully shaped from 3mm clear acrylic. One screw fixes the clips to a backing board of your choice. The kit to mount one ball includes the acrylic mounting clip, 25mm x 5.4mm fixing screw with nut and washers.

SBC1	Ball Clip - Cricket/Baseball	Each
SBC2	Sports Ball Clip - Tennis	Each
SBC3	Sports Ball Clip - Golf	Each

Cricket Bat Clips

This acrylic clip can hold a cricket bat flat side out or wedge side out. The bat is laid into the clip toe first and then the handle pushed into the claw. Use a piece of polywrap or similar wrapped around the rubber handle cover to help ease it in.

The CBC1 is for bats with toes up to 28mm thick. The CBC2 is for bats with toes up to 38mm thick. Supplied with full instructions and all fixings.

CBC1	Cricket Bat Clip - Normal Toe	Each
CBC2	Cricket Bat Clip - Wider Toe	Each



Sport Shirt Framing System®

The traditional method of framing shirts is very time consuming and too much of a challenge for a lot of framers. The Sports Shirt Framing System® makes the job a much easier proposition.

SSFS1	Sports Shirt Framing System (White)	Each
SSFS3	Sports Shirt Framing System (Black)	Each



Miscellaneous



This is the section where you can find all those little extras for your framing workshop.

Miscellaneous

Mountboard Decoration

Foam Biseaux

The foam strips are already bevelled (60 degrees) on both sides, so if you make a mistake you can always use the other side. With the special mark line it is easy to fix the self adhesive mat decoration tape. Cut the foam strips with your standard mountcutter (60 degrees) or with the special foam biseaux cutter, which has been specifically designed for this task. Mount the strips on the back of your mount and your mount is ready.

Per
FOST1 1m Bevelled Foam Strips 20

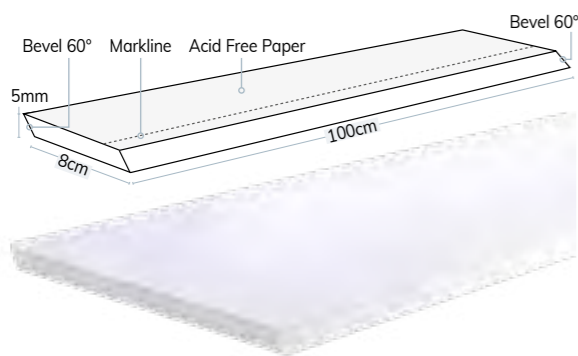

Mount Bevel Tape **NEW**

Slater Harrison's self-adhesive mount decoration tape is especially designed for covering foam strips to make a mount with a deep bevel. Available in 5 popular ColourMount colours.

The rolls are 48mm x 25m (1 7/8" x 82').



		Per
SHDBT801	ColourMount Bevel Tape Ivory	Roll
SHDBT864	ColourMount Bevel Tape Old Gold	Roll
SHDBT871	ColourMount Bevel Tape White	Roll
SHDBT872	ColourMount Bevel Tape Black	Roll
SHDBT981	ColourMount Bevel Tape Off White	Roll



Ruling Pen

The traditional method for easy and accurate lines and washes.

PEN1 Ruling Pen Each



Washline Corner Gauge

Used for easy and accurate lines and washes.

GAUGE1 Washline Corner Gauge Each



Wood Finishing Products

Black Polish

A high quality black stained French polish that is suitable for ebonising. It stops the grain of the wood showing through. Apply with a French polishing mop or with a rubber in accordance with traditional French Polishing techniques.

BLPOL2 250ml Black Polish Each

Button Polish

Button Polish is a traditional high quality French polish that is suitable for antique finishes. It warms new or pale looking wood and covers any blemishes or marks. Apply with a French polishing mop or with a rubber in accordance with traditional French polishing techniques.

BUTP1 250ml Button Polish Each



Bronze Brush

Best quality uniform bronze strand brush. Used to clean mouldings, carvings and stone. Recommended for opening up the grain in wood before applying Liming Wax.

BRUSH1 Bronze Brush Each



All colour swatches are for guidance only. Actual colours may vary.

Finishing Oil

Finishing Oil is a blend of high quality oils which nourish and enhance the colour of the wood. Matt, satin or gloss finish depending upon the number of coats applied. Ideal for surfaces requiring a hard wearing and water resistant finish.

Suitable for use on worktops, kitchen tables, bathroom furniture, cork, stone and terracotta. It is also safe for toys (EN71 Approved).

FINOIL 250ml Finishing Oil Each



Gloves - Disposable

Disposable gloves that protect hands from messy or skin irritating tasks. Thin for fingertip sensitivity.

DG1 Disposable Gloves 100 Per



Gilt Cream

Gilt Cream is an easy to apply, gilt finish for restoring old or damaged gilding work. It also gives a gilt finish to new surfaces. All colours are intermixable.



GC12 30ml Chantilly Gilt Cream Each
 GC13 30ml Trianon Gilt Cream Each
 GC14 30ml Versailles Gilt Cream Each

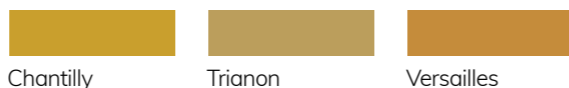

Gloves - Polyester

Extremely comfortable and breathable, a good alternative to cotton. Useful for keeping mountboards and plain timbers free from greasy finger marks. Washable at 40°C for extended life. Ideal for intricate handling of valuable items, making them suitable for conservation framing.

DG3 Polyester Gloves 3 Pairs Per



Goldfinger

Used for gilding, restoration work and plaster or wood decoration. Apply with a soft cloth or finger then buff to a high lustre. Goldfinger can be thinned with white spirit and used with a brush for finer intricate work. Very economical in use and takes best on porous or slightly abraded surfaces.



GF01 22ml Antique Gold Goldfinger Tube Per
 GF02 22ml Copper Goldfinger Tube
 GF03 22ml Green Gold Goldfinger Tube
 GF04 22ml Imitation Silver Goldfinger Tube
 GF05 22ml Sovereign Gold Goldfinger Tube

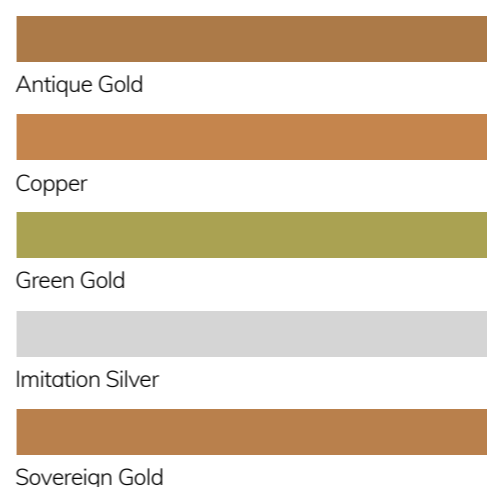

Gold and Silver Leaf

Ideal for achieving a traditional bright finish and creating virtually the same effect as real gold leaf. Great for beginners.

METAL/GL Metal Gold Leaf 140 x 140mm 25 Sheets Per
 METAL/SL Metal Silver Leaf 140 x 140mm 25 Sheets



Pale French Polish

Pale French Polish is a high quality colourless and transparent polish made from the finest quality pale de-waxed shellac. It produces a warm and natural effect bringing out the natural graining of the wood. It is ideal for preserving the colour on marquetry work. Apply with a French Polishing mop or with a rubber in accordance with traditional French Polishing techniques.

FRPOL2 250ml Special Pale French Polish Each



All colour swatches are for guidance only. Actual colours may vary.

Retouch Crayons

Retouch crayons are used for filling and masking superficial scratches. It expands and contracts with the wood so doesn't shrink or drop out. Tins of single colours are available to order.

Per
RC2 Retouch Crayons Wood Set (10 sticks) Tin



Retouch Cream

Retouch Cream is a soft creamy wax for filling mitre joints and pin holes on frames or furniture, restoring colour and disguising dents and chips. It dries hard and both colours are intermixable.

CR08 30ml Black Retouch Cream Each
CR09 30ml White Retouch Cream Each



Spirit Based Dye

Spirit Wood Dye is ideal for use on hardwoods such as mahogany and oak. A traditional dye which penetrates deep into the wood making it good for colouring previously finished woods i.e. antique restoration. It is easy to apply and can be mixed together to obtain intermediate shades.



SB11 250ml Light Oak Spirit Based Dye Each
SB15 250ml Teak Spirit Based Dye Each
SB16 250ml Walnut Spirit Based Dye Each
SB17 250ml Medium Oak Spirit Based Dye Each
SB22 250ml Ebony Spirit Based Dye Each



Steel Wool

Extra fine steel wool specifically designed for applying polish and cleaning delicate surfaces. Ideal for cutting back intermediate layers of French polish and lacquers. It is virtually oil free and crumble resistant and is endorsed by the Guild of Master Craftsmen.

SW1 Steel Wool Grade 0000 (100g) Each
SW3 Steel Wool Grade 0000 (1kg) Each



Tack Cloths

Resin impregnated to remove dust and lint from wooden surfaces after sanding, prior to staining, waxing or French polishing. Cloths are silicone free.

Per
TC1 Tack Cloths (pack of 3) Pack
TC2 Tack Cloths (pack of 10) Pack



Black Patinating Wax

Creates striking effects on all types of material such as metal, wood and plaster. Ideal for ageing modern furniture and disguising repairs to old and new furniture. It can also be used for adding a coloured finish or highlighting areas on finished pieces and faking grime on picture frames.

WAXBPF 250ml Black Patinating Wax Each



Liquid Wax Polish

Made from a blend of waxes including carnauba wax. It feeds, polishes and helps prevent wood from drying out. It is highly lustrous and hardwearing and ideal for covering large surfaces. Gives good resistance to finger and water marks.

WAX3 500ml Liquid Wax Polish Clear Each



All colour swatches are for guidance only. Actual colours may vary.

Liming Wax

A white wax that is used to create a limed effect on oak and other hardwoods. Can also be used on stained wood to create different effects. It is easy to use and safe for toys (EN71 Part 3 Approved).

LW1	250ml Liming Wax	Each
LW2	500ml Liming Wax	Each



Wax Polish

Made from a blend of waxes, including carnauba wax. It nourishes and protects all types of wood, including lacquers and French polishes. It feeds, polishes and helps prevent wood from drying out. It is highly lustrous and hardwearing and ideal for covering small surfaces. Gives good resistance to finger and water marks. It is silicone free and safe to use on toys (EN71 Part 3 Approved).



WAX1	500ml Wax Polish Clear	Each
WAX2	150ml Wax Polish Clear	Each
WAX13	500ml Wax Polish Walnut	Each
WAX14	500ml Wax Polish Medium Oak	Each
WAX17	500ml Wax Polish Dark Oak	Each
WAX18	500ml Wax Polish Tudor Oak	Each
WAX21	500ml Wax Polish Neutral	Each



Verdigris Wax

Creates green hues of oxidised copper and brass on materials such as metal, wood and plaster. Ideal for decorating household objects, it buffs to a soft sheen, and can also be applied as a wax finish to bare or coloured wood.

WAXVE	250ml Verdigris Wax	Each
-------	---------------------	------



Wax Filler Tin

A pliable filler for cracks, crevices and nail holes, perfect for picture frames and wood furniture. Will not dry out or shrink.



WAXF3	Tin Ivory Wax Filler (56g)	Each
WAXF4	Tin Black Wax Filler (56g)	Each
WAXF5	Tin White Wax Filler (56g)	Each
WAXF6	Tin Dark Walnut Wax Filler (56g)	Each
WAXF7	Tin Grey Wax Filler (56g)	Each
WAXF8	Tin Gold Wax Filler (56g)	Each
WAXF9	Tin Dark Gold Wax Filler (56g)	Each
WAXF10	Tin Silver Wax Filler (56g)	Each
WAXF14	Tin Walnut Wax Filler (56g)	Each

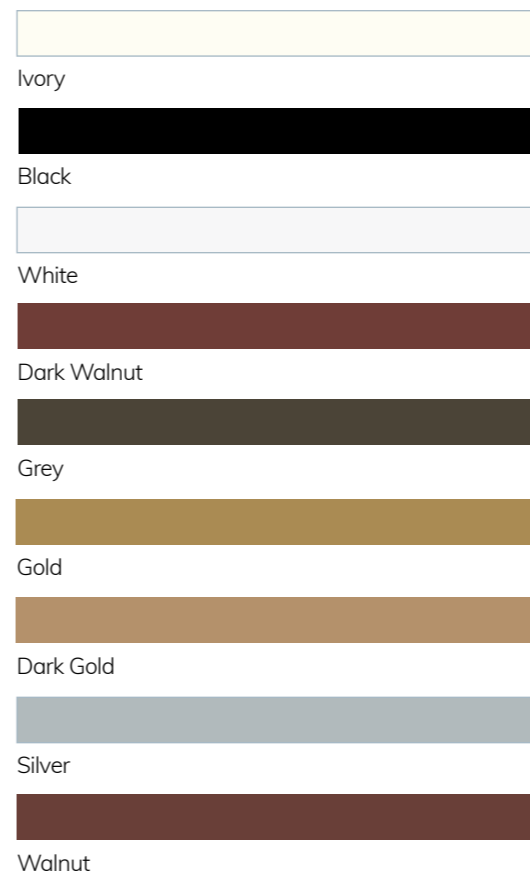

Wax Filler Stick

Blended wax filler for repairing finished frames. Fills small to medium holes, cracks and scratches without sanding or having to strip the finish. All colours are intermixable

WFS00	White Wax Filler Stick	Each
WFS02	Light Oak Wax Filler Stick	Each
WFS12	Ebony Wax Filler Stick	Each



Wood Filler

Water based multi-purpose filler used to fill and repair surface damage in wood. It is quick drying, flexible, shrink/crack resistant, easily sanded and may be screwed and nailed. Suitable for both interior and exterior use and low odour. Wood filler may be stained, varnished, waxed or painted. When using outdoors protect with a suitable exterior grade finish.

WF01	125ml Wood Filler Neutral	Each
WF02	125ml Wood Filler Antique Pine	Each



All colour swatches are for guidance only. Actual colours may vary.

Palette Wood Dyes

Water based palette wood dyes are ideal for colouring interior bare wood work leaving the natural beauty of the grain visible. Suitable for soft and hardwoods. Use prior to oil, wax, varnish and French polish finishes. Uniform results can be achieved on large and small surfaces such as furniture, floors, doors, cupboards, frames etc. They are EN 71 - Part 3 Approved so safe for use on toys. Available in a range of wood shades which can be mixed to create unique colours. The dyes can also be mixed with Liberon natural finish varnishes. Endorsed by the Guild of Master Craftsmen.



WB11	500ml Light Oak Water Based Dye	Each
WB12	500ml Antique Pine Water Based Dye	Each
WB13	500ml Golden Pine Water Based Dye	Each
WB17	500ml Medium Oak Water Based Dye	Each
WB20	500ml Dark Oak Water Based Dye	Each
WB21	500ml Tudor Oak Water Based Dye	Each
WB22	500ml Ebony Water Based Dye	Each
WB34	250ml White Water Based Dye	Each



Please test any glue product before using. Wessex Pictures cannot be held responsible for any damage caused.

Wood Glue

Wessex own brand PVA woodworking glue. Fast setting and dries clear. D3 high water resistance rating.

		Per
RW150	150 ml PVA Wood Adhesive	Bottle
RW250	250 ml PVA Wood Adhesive	Bottle
RW500	500 ml PVA Wood Adhesive	Bottle
RW1000	1 ltr PVA Wood Adhesive	Bottle
RW5000	5 ltr PVA Wood Adhesive	Bottle



Plastic Wood Glue

Used to join plastic mouldings. The activator speeds up the curing time.

		Per
IFG1	50ml Plastic Moulding Glue	Bottle
IFG2	200ml Instant Framing Glue Activator	Can



Neutral pH Adhesive

Neutral pH adhesive is a clear drying PVA adhesive which remains flexible and doesn't go brittle. Buffered for added protection. Ideal for use with Japanese acid free paper.

		Per
NPHA1	227ml (8oz) Neutral pH Adhesive	Bottle



Spray Adhesive

All 3M spray adhesives give an even coverage. Photomount - formulated for use with photographs. Displaymount - a general high tack adhesive. Spraymount - a general low tack adhesive.

PH1	400ml 3M Photomount	Each
PH2	400ml 3M Displaymount	Each
PH3	400ml 3M Spraymount	Each



Picture Cord

16 plait low stretch polyester. Better UV resistance than nylon cord.

		Per
132 Meters		Reel
2N	1.6mm Polyester Cord 54kg Breaking Load	Reel
4N	2.0mm Polyester Cord 91kg Breaking Load	Reel
6N	2.5mm Polyester Cord 122kg Breaking Load	Reel
10N	3.5mm Polyester Cord 230kg Breaking Load	Reel
1000 Meters		Reel
AC1	2mm Polyester Cord 91kg Breaking Load	Reel



Primed Canvas

Medium cotton canvas coated with an acrylic primer. Ready to use surface. Ideal for both oils and acrylics.

		Per
RC39	1m x 5m (39" x 196")	Roll
RC78	2m x 5m (78" x 196")	Roll



Stretcher Mouldings

Makes instant stretcher bars any length from stock.
Convenient, quick and very effective.

Stretcher mouldings are made from finger jointed pine and are used for stretching canvases. Stretch your canvas over the moulding and hang on the wall for a contemporary gallery look, or frame the stretched canvas for a more traditional appearance.



			Per
STMO	Standard Stretcher Moulding	37mm x 20mm (1½" x ¾")	Metre
STMO2	2 Way Stretcher Moulding with grooves	42mm x 30mm (1⅝" x 1⅛")	Metre
STMO3	2-Way Solid Stretcher Moulding	42mm x 30mm (1⅝" x 1⅛")	Metre

		Per
STMB	6mm Plywood Bracing Strip (8ft)	Each
STMBW	6mm Plywood Corner Plates (4 per pack)	Pack

STMO and STMO2 take the 6mm plywood corner plates



Mitre to required lengths allowing for expansion.



If using a Morsø, support groove with corner plates.



Accurately insert corner plates, finger tight, one per bar, then assemble frame.



Check for distortion. Staple across corners for more stability.



Tack or staple the canvas along the sides and ends. Check image alignment.



Fix all round, including corners. Keep tension even.

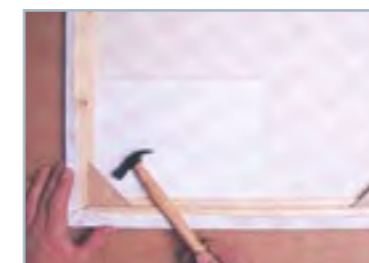

Take up slack as required. Protect canvas with scrap card.



Prevent plate movement with beads of glue. (Break glue before re-stretching).

Stretchers

Stretchers are a rigid frame made from knot free pine, and they have expandable corners.

The slotted ends fit together seamlessly and no special tools are required for assembly.

Over time a stretched canvas can loose tension. The slotted joints allow wedges to be tapped in to open up them up and re-tension the canvas. Wedges are included.

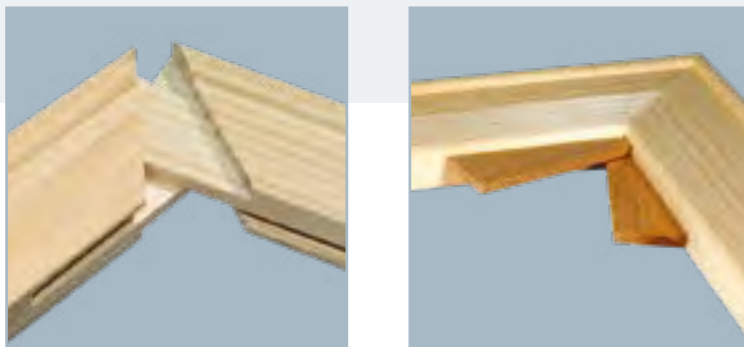

44mm wide x 18mm deep.

SP08	203mm (8")
SP10	254mm (10")
SP11	279mm (11")
SP12	305mm (12")
SP14	356mm (14")
SP16	406mm (16")
SP18	457mm (18")
SP20	508mm (20")
SP22	559mm (22")
SP24	610mm (24")
SP26	660mm (26")
SP28	711mm (28")
SP30	762mm (30")

Subframe

Subframes provide a strong framing support for your artwork and make it possible to use smaller mouldings for larger pictures.

Subframes can be used as a very strong hanging system. Fix a length of subframe to the wall with the bevel the opposite way to that inside the frame. Make sure it is absolutely level. Place the picture over the wall mounted bevel, it will sit flush to the wall.

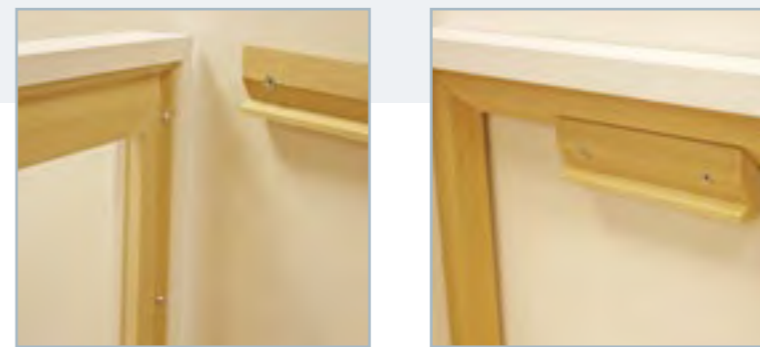

Made from Obeche and comes in a 41mm x 18mm section.

PW219 $1\frac{5}{8}$ " (41mm) Subframe Per Metre



Econospace

A neutral pH plastic peel & stick art and glass separator that can be used in wood or metal frames.

It bonds to the edge of the glass in a picture frame to make airspace between the art and glass. The airspace helps prevent mould, paper buckling, image transfer and adhesion to the glass. It is hollow to keep it lightweight and is rigid so it doesn't sag in the frame. Cuts cleanly and easily with a blade.



		Per
ECON03	EconoSpace ES-062 CLEAR 1.5mm	31m/100ft
ECON01	EconoSpace ES-125 CLEAR 3mm	31m/100ft
ECON02	EconoSpace ES-250 CLEAR 6mm	18m/60ft
ECON04	EconoSpace ES-375 CLEAR 9.5mm	18m/60ft

Packing Materials

Bubble Wrap

Small bubble polythene film which is lightweight and provides excellent protection. 100m per roll.

		Per
BW1	Bubble Wrap - 750mm (29 ¹ / ₁₆ ") Wide	Roll
BW2	Bubble Wrap - 1500mm (59") Wide	Roll



Corrugated Paper

Brown kraft fluted roll which offers very good protection. Easy to cut. 75m per roll.

		Per
CSF1	Corrugated Paper - 650mm (25 ¹ / ₂ ")	Roll
CSF2	Corrugated Paper - 1300mm (51")	Roll
CSF3	Corrugated Paper - 1800mm (70 ¹ / ₄ ")	Roll



Handy Wrap

Can be used to wrap bundles together and used in place of tape when wrapping things such as parcels. It only sticks to itself. Rolls are 15µ thick.

		Per
AW1	Handy Wrap System (10 x AW2 Rolls + 1 x AW3 Handle)	Set
AW2	150m Handy Wrap Rolls	Roll
AW3	Handy Wrap Handle	Each



Polypropylene Film

Clear wrapping film which is moisture resistant. Ideal for wrapping mounted prints. 120m per roll.

		Per
POLY32	32" Polypropylene Film - 813mm (32")	Roll



Protective Corners - Folded

White faced fluted board. Fold together, the inner flap holds the corner in place. No tape or staples required. Supplied flat packed - 200 per box.

		Per
PC20	Protective Corners- 16mm ($\frac{5}{8}$ ")	Box
PC30	Protective Corners- 25mm (1")	Box
PC40	Protective Corners- 38mm (1 $\frac{1}{2}$ ")	Box

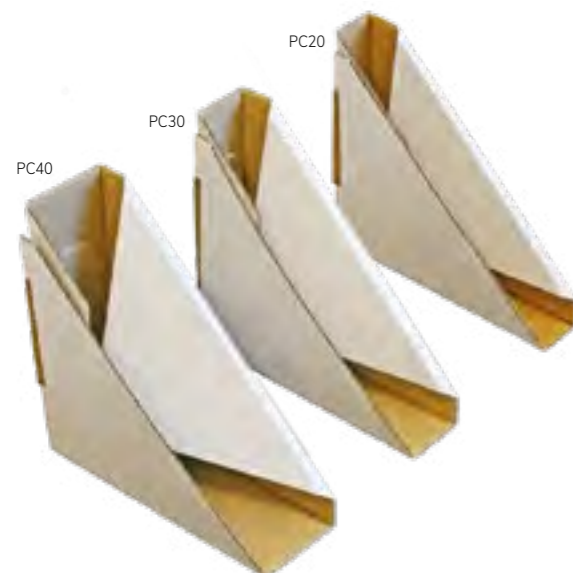

Protective Corners - Taped or Stapled

White faced fluted board which has to be taped or stapled together - 500 per box.

		Per
PC10	Protective Corners- 10mm ($\frac{3}{8}$ ")	Box



Protective U Foam Edging

2 metre lengths of U shaped PE-LD (polyethylene low density) foam. It is ideal for protecting the edges of frames and the tulip shape helps grip the edge of the frame. Can be held in place with either tape or Handywrap. The sizes indicate the min. and max. recommended depth of frame to be protected. It is sold in multiples of 10 lengths (20 metres). Quantity discounts available.

		Per
PFOAM18	10-20mm 'U' Foam Edging	20m
PFOAM28	15-25mm 'U' Foam Edging	20m
PFOAM35	20-35mm 'U' Foam Edging	20m
PFOAM42	30-45mm 'U' Foam Edging	20m



Protective U Foam Corners

U shaped PE-LD (polyethylene low density) foam pre-cut corners. Ideal for protecting the corners of frames. The tulip shape helps to grip the frame. Sizes indicate the min. and max. recommended depth of frame to be protected. Quantity discounts available.

		Per
PCFOAM18	10-20mm 'U' Foam Corners	100
PCFOAM28	15-25mm 'U' Foam Corners	100
PCFOAM35	20-35mm 'U' Foam Corners	100
PCFOAM42	30-45mm 'U' Foam Corners	100



Self Sealing Polybags

Ideal for packing cut mounts or mounted prints. The bags are 10mm larger than the size quoted.

		Per
PB100150	Polybags 10 x 15cm	100
PB130180	Polybags 13 x 18cm	100
PB150150	Polybags 15 x 15cm	100
PB150210	Polybags 15 x 21cm	100
PB180240	Polybags 18 x 24cm	100
PB200200	Polybags 20 x 20cm	100
PB200300	Polybags 20 x 30cm	100
PB200500	Polybags 20 x 50cm	100
PB200600	Polybags 20 x 60cm	100
PB210297	Polybags 21 x 29.7cm	100
PB240300	Polybags 24 x 30cm	100
PB250500	Polybags 25 x 50cm	100
PB300300	Polybags 30 x 30cm	100
PB300400	Polybags 30 x 40cm	100
PB400400	Polybags 40 x 40cm	100
PB400500	Polybags 40 x 50cm	100
PB500600	Polybags 50 x 60cm	100
PB500700	Polybags 50 x 70cm	100
PB600800	Polybags 60 x 80cm	100
PB7001000	Polybags 70 x 100cm	100



Wrapping Paper

This paper helps to protect items from knocks and moisture, making it ideal for all general purpose wrapping and packing applications.

		Per
PAPER24	24" x 656ft Brown Wrapping Paper	Roll
PAPER36	36" x 656ft Brown Wrapping Paper	Roll
PAPER45	45 $\frac{1}{4}$ " x 738ft Pure Kraft Paper	Roll



Costing and Pricing

Costing & Pricing



With a 30 day free trial, no ongoing costs and free upgrades, the Wessex Pricing Programme has been designed with framers in mind. Evolving for over 15 years to ensure your business runs as quickly and smoothly as possible.

Accurate pricing for the professional framer



The Wessex Pricing Programme allows you to get on with framing, while it takes care of the admin.

Easily calculate price using parameters that can be changed to suit your business whilst keeping track of work tickets, invoices, moulding stock and much more.

In the current challenging environment, a tool which gives consistent pricing helps get the work done on time, every time. Storing easily retrievable records to give your framing business the edge.

Unlike many other programs, you can use Wessex Professional on multiple computers without having to pay again.

WPP4F Wessex Pricing Programme Each



- 30 Trial for 30 days free
- £ No ongoing costs
- ↑ All upgrades are free

Features

- Sophisticated frame pricing
- Quick to use
- Allows for stacked mouldings
- Easily change between in, cm or mm
- Reminds if work is likely to need oversized mountboard or glass
- Set of 'How To' videos in Help section
- Easily give discounts
- Database file compatible with Microsoft Office (and other suites)
- Change pricing of items to reflect your business
- Get notified if a moulding has low stock and needs to be ordered, or is discontinued
- Add additional cost with/without VAT
- Useful calculator for framers
- Input an item's current location
- Option to issue prices in whole pounds
- Automatic backup of database and values
- Multiple options for mountboard and glass types
- Running job total shown on main form
- Save multiple work tickets on 1 invoice
- Quantity of moulding needed shown on work tickets
- Retrieve work tickets by invoice no, work ticket no, name, date or moulding
- Gives collection date based on your turnaround time, incl. days you're shut
- Produces list of work to be completed, in order of collection date
- Mount colours can be printed on work tickets
- Bulk update supplier mouldings
- Easily networked
- Password protect major settings



Framers Pricing App

The Wessex Pricing Programme is available as an app for your Android phone or tablet.

Making it easy for you to work out frame prices at home, in the office or on the road.

- Prices worked out the same way as the Wessex Pricing Programme for PC (WPP4)
- Simple and intuitive to use
- Easy to change parameters to configure programme to your business
- Price any Wessex moulding using the reference number
- Any other moulding can be priced using a moulding code (given by the program)
- Choose £, \$ or € to show final price

Get the Wessex Framers Pricing App for just £35.99

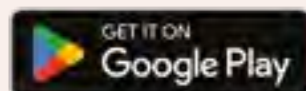

Index and Terms

Index & Terms of Trading



Find what you are looking for quickly and easily with our comprehensive index.

Item	Page
Aluminium Chop	12 - 13
A+ Automation Accessories	191
Acrylic - Artshield UV	61
Acrylic - Cast	65
Acrylic - Diffused	65
Acrylic - Extruded	65
Acrylic - Tru Vue Optium	47
Acrylic - UV Cast Acrylic	59
Acrylic Cleaner	66
Art-Bak	127
Backing Board Whitecore	130
Barrier Board	131
Bendable Fixing Plates	139
Bevelled Mirrors	64
Blade Sharpening	175
Blades - C&H	152
Blades - Scalpel	152
Blades - Snap Off	153
Blades - Stanley	152
Blades - Steel	151
Blister Packs	148 - 151
Box Board	130
Brevetti Accessories	185
Britback	131
Bronze Brush	257
Bubblewrap	271
Butt Hinges	136
Canvas Offsets	136
Clip Over Hangers	138
Compressor Accessories	221
Compressors	220 - 222
Cord	265
Corri-Cor	126
Corrugated Paper	271
Cutting Mats	225
D Rings	138
Disc Plate Hangers	138
Display Board	130
Display Fabric - Brushed Nylon	251
Display Stands	248 - 249
Dry Mounting - Accessories	242
Dry Mounting - Heat Activated Films	242 - 243
Dry Mounting - Pressure Sensitive Films	232 - 233
Dust Extractors	222
Econospace	270
Emo Clips	138
Escutcheon Pins	139
F-3100	216
Fabrigrip	251
Ferrules	139

Item	Page
Finishing Oil	258
Firescreen Fittings	139
Foam Biseaux	256
Foam Centred Board	128 - 129
Frame Bumpers	140
Gilt Cream	258
Glass - Antique Silvered (Mirror)	64
Glass - Artglass	35 - 45
Glass - Cut Size Float	64
Glass - Diffused (Acid Etched)	65
Glass - Float	64
Glass - Laminated	64
Glass - Safety Backed Mirror	64
Glass - Silvered (Mirror)	64
Glass - Tru Vue	19 - 45
Glass & Acrylic Cleaning	66
Glass Cutters	67
Glass & Board Cutter - Fletcher	216 - 219
Glass & Board Cutters - Keencut	192 - 209
Glass Gauntlets	68
Glass Plates	141
Glass Pliers	67
Glass Sharp Edge Removing	67
Gloves - Glass Handling	68
Gloves - Gripper	68
Gloves - Disposable	258
Gloves - Polyester	258
Glue - Neutral pH	265
Glue - Plastic	264
Glue - Wood	264
Gold & Silver Leaf	259
Goldfinger	259
Grey Board	130
Gummed Cloth Hangers	140
Hand Tools	224 - 227
Handy Wrap	271
Hanging System	246
Hardboard	131
Hardwall Hooks Toly	140
Hook & Loop	250
Keencut Accessories	212 - 213
Keencut Bench	210
Keencut Cutters	200
Kraft Lined Board	130
Laminating - Heat Activated Films	241
Laminating - Pressure Sensitive Films	234
Measuring Tape	67
MDF (Medium Density Fibreboard)	128
Mitre Saws - Brevetti	176 - 180
Morsø Accessories	173 - 175

Item	Page
Morsø Mitring Machines	168 - 172
Moulding Hooks	142
Mountboard - Colourmount	98 - 104
Mountboard - Crescent	72 - 85
Mountboard - Daler	108 - 110
Mountboard - Larson Juhl	88 - 94
Mountboard - Wessex	114
Mount Bevel Tape	256
Mountcutters - Fletcher	216 - 217
Mountcutters - Keencut	192 - 193
Mountcutting Service	116 - 122
Nubord	129
Panel Pins	143
Picture Chain	142
Picture Hangers	142
Picture Pins	143
Picture Wire	144
Plate Hooks	143
Plate Rings	143
Polish - Black	257
Polish - Button	257
Polish - French	259
Polybags - Self Sealing	273
Polypropylene Wrapping Film	271
Pricing Programme	276 - 278
Primed Canvas	265
Print Browsers	247
Protective Corners - Cardboard	272
Protective Corners - Foam	272
Pulpboard	131
Repair Plates	145
Retouch Crayons	260
Retouch Cream	260
Rings & Clips	144
Rivets	136
Ruling Pen	257
Ryno Board	130
Saw Tooth Hangers	146
Scalpel Handles	152
Screw Eyes	145
Screw Rings	145
Screws	154
Security Fittings	136 - 137
Self Adhesive Boards	132
Shrink Wrap Film	227
Snap Off Knives	153
Split Rings	146
Sport Shirt Framing System	253
Sports Ball Clips	252
Spray Adhesive	265

Item	Page
Spring Clips	146
Steel Wool	261
Straight Edges	229
Strap Hangers	145
Stretcher Bars	268
Stretcher Mouldings	266
Strut Backs	153
Strut Hinges	146
Styrene - Clear	65
Styrene - Diffused	65
Subframe	268
Suggested Screws For Fittings	155
T Square	68
Tack Cloths	261
Tape Dispensers	165
Tapes - Acid Free	161 - 165
Tapes - Double Sided	160 - 161
Tapes - Gummed	160
Tapes - Self Adhesive	158 - 159
Top Fixing Screw Rings	146
Training School	228 - 229
Tray Handles	147
Triangle Hangers	147
Triangle Points - Fletcher	139
Tru Vue Seamed Optium	53
Turn Buttons	147
Underpinner Wedges - A+ Automation	191
Underpinner Wedges - Brevetti	185
Underpinner Wedges - Gielle	191
Underpinners - A+ Automation	186 - 190
Underpinners - Brevetti	181 - 184
Vacuum Presses	238
Wall Hooks - Brass	144
Wall Plates	148
Washline Gauge	257
Wax - Black Bison	262
Wax - Black Patinating	261
Wax - Filler	263
Wax - Filler Sticks	263
Wax - Liming	262
Wax - Liquid	261
Wax - Verdigris	262
Wood Dye - Spirit based	260
Wood Dye - Water Based	264
Wood Filler	263
Wrapping Paper	273
X Hooks - Cartons	151
Z Clips	148

Terms of Trading

Accounts

Credit facilities available subject to satisfactory references.
(Bankers and two trade references within framing industry required).

Terms of settlement

30 days nett (Account customers only).

Payment methods

Cash, cheque, most credit and debit cards, BACS, by prior arrangement.

On overdue accounts we reserve the right to make a charge to cover interest and additional costs of collection, represented and returned cheques will be charged £15.00.

Goods ordered against Pro-forma invoices will only be held for a maximum of 21 days. Minimum invoice value before VAT and carriage (including back orders) £15.00.

VAT

Prices do not include VAT, which will be charged nett of discount at the standard rate.

Quantity discounts - Available on request

All sizes in this catalogue are nominal - E&OE - Jan 2024

Carriage paid orders via Wessex Van Delivery service - £75.00

Cut off times:

Van delivery service 2.30pm • National carriers 12 noon.

Back orders under £30 will be sent with your next carriage paid order.

Minimum carriage and small order charge - £7.50

Carriage paid orders via National Carrier:

UK Mainland £125 (excluding Northern Ireland, Channel Islands, Isle of Wight, Scotland and Scottish Highlands)

Northern Ireland, Channel Islands, Isle of Wight, Scotland and Scottish Highlands - POA

Notification of non-delivery must be made within 7 days of receipt of invoice and short delivery or damage goods within 3 days of receipt of goods.

Please check your goods carefully as we do not accept mitred lengths of moulding or cut mounts for credit.

All goods remain the property of Wessex Pictures
(AL. Younger Ltd) until paid for in full.

Our policy is always to keep prices as competitive as possible, but price increases are sometimes unavoidable after a price list has been printed. We operate a price ruling at the date of despatch policy, and recommend that you telephone to confirm current prices, if these are an important factor. Alternatively, visit wessexpictures.com where prices are updated daily.





WESSEX PICTURES

Ashford

Units 2-3 Hilton Business Centre, Kingsnorth Industrial Estate, Wotton Road, Ashford, Kent TN23 6LL
01233 637104

Bournemouth

Gordleton Industrial Park, Sway Road, Pennington, Lymington, Hampshire SO41 8JD
01590 681681

Dereham

4 Charles Wood Road, Rash's Green Industrial Estate, Dereham, Norfolk NR19 1SX
01362 690002

Leamington Spa

6 Berrington Road, Sydenham Industrial Estate, Royal Leamington Spa, CV31 1NB
01926 421984

London

Unit 1142, The Axis Centre, Cleeve Road, Leatherhead KT22 7RD
01372 377738

Oldham

Units 5&6, Under Lane, Chadderton, Oldham, Lancashire OL9 7PP
01616 812959

Wessex Fine Art

Gordleton Industrial Park, Sway Road, Pennington, Lymington, Hampshire SO41 8JD
01590 681683

wessexpictures.com

sales@wessexpictures.com